

CATALYST 5X

USER INSTRUCTION MANUAL & WARRANTY



2021-05-13

I. INTRODUCTION

Thank you for purchasing a Ki Mobility wheelchair!



WARNING: Do not use this without first reading this entire manual. Use without first reading this entire manual could result in serious injury to the user and/or attendant.

Ki Mobility recommends training by an Assistive Technology Professional (ATP) or other competent clinical or technical professional in the safe use of this chair prior to use.

If you have any questions or concerns about any aspect of this wheelchair, this manual or the service provided, do not hesitate to contact your authorized supplier, an authorized representative or Ki Mobility. Ki Mobility can be reached at:

(1)715-254-0991



Ki Mobility
5201 Woodward Drive
Stevens Point, WI 54481
U.S.A



www.kimobility.com

Or via our Authorized EU Representative:

EC REP Ki Mobility Portugal, Unipessoal Lda
Rua Santos Pousada, 157 4º andar sala 17
4000-485 Porto



II. TABLE OF CONTENTS

I. INTRODUCTION

II. TABLE OF CONTENTS

III. NOTICE - READ BEFORE USE

A.	Intended Use	3
B.	Your Safety	3
C.	Signal Words.....	3
D.	Serial Number Identification.....	4
E.	Symbol Glossary	4
F.	General Warnings and Cautions	5
G.	Positioning Belts or Harnesses	6
H.	Riding Your Wheelchair	6
I.	Power Drives.....	8
J.	Your Wheelchair and the Environment	9
K.	Modifying your Wheelchair	9
L.	Wheelchair Stability	9
M.	Aftermarket Seating	10

IV. WHEELCHAIR USE & CONFIGURATION

A.	Ascending Stairs	11
B.	Descending Stairs	11
C.	Transfers	12
D.	Transit Use	12
E.	Cushion Use	15
F.	Your Catalyst 5Vx & Its Parts	16
G.	Height Adjustable T-Arm.....	17
H.	Swing Away Armrests	18
I.	Height Adjustable Flip Back T-Arm	19
J.	Swing Away Hangers	21
K.	Swing Away Hangers with 4-Way Latch	22
L.	Extension Tubes.....	23
M.	Elevating Leg Rest	23
N.	Pro Elevating Leg Rest	24
O.	Adjustable Height Backrest	26
P.	Half Folding Backrest	27
Q.	Rear Wheels	28
R.	Wheel Locks	29
S.	Anti-Tips	30
T.	Upholstery Fabric	34
U.	Seat Upholstery	34
V.	Oxygen Tank Holder.....	35
W.	Surface Temperature.....	35
X.	Step Tube	36
Y.	Transit Wheels.....	36

V. MAINTENANCE AND CARE

A.	Maintenance Table	37
B.	Cleaning.....	38
C.	Storage.....	38
D.	Disposal.....	39

VI. TROUBLESHOOTING

A.	Symptoms and Solutions	40
----	------------------------------	----

VII. WARRANTY..... 41

III. NOTICE - READ BEFORE USE

A. Intended Use

Ki Mobility Manual wheelchairs are manually operated devices with wheels that are intended for medical purposes to provide mobility to persons restricted to a sitting position.

B. Your Safety

Any serious adverse events or injuries related to the use of your wheelchair or its accessories must be reported immediately if the incident directly or indirectly leads to serious health decline or death of the user or other person. Report any serious events and/or injuries to Ki Mobility and, if required by local regulation, the competent health authority where the user and/or other person legally reside.

Do not use this wheelchair without first reading this entire manual. BEFORE riding, you should be trained in the safe use of this chair by an Assistive Technology Professional (ATP) or other competent clinical or technical professional. Ki Mobility manufactures many different wheelchairs that might meet your needs. The recognized best practice for selecting a wheelchair is to consult with an ATP or other competent technical professional and an experienced clinical professional such as a physical therapist, occupational therapist or physician. Final selection of the type of wheelchair, options and adjustments rests solely with you and your technical and clinical professionals. The options you choose, and the set-up and adjustment of the wheelchair have a direct impact on its performance, stability and its ability to meet your needs. Factors to consider that affect your safety and stability are:

- a. Your personal abilities and capabilities including strength, balance and coordination.
- b. The types of hazards and obstacles you might encounter during your day.
- c. The specific dimensions, options and set up. In particular, the seat height, seat depth, seat angle, back angle, size and position of the rear wheels and size and position of the front casters.

C. Signal Words

Within this manual you will find what are referred to as “Signal” words. These words are used to identify and convey the severity of varying hazards. Before using this chair you, and each person who may assist you, should read this entire manual. Please note the Signal word and consider any notes, cautions or warnings. Make sure to follow all instructions and use your chair safely. The Signal word refers to a hazard or unsafe practice that may cause severe injury or death to you or to other persons. The “Warnings” are in three main categories, as follows:

NOTE – Note indicates a potentially hazardous situation which, if not avoided, could result in a decline in the performance of the chair or damage to your wheelchair.

CAUTION

CAUTION: Caution indicates a potentially hazardous situation which, if not avoided, could result in damage to your wheelchair and injury to you.

WARNING

WARNING: Warning indicates a potentially hazardous situation which, if not avoided, could result in serious injury or death.

These signal words will be placed throughout the manual, where appropriate to highlight the hazardous situation. Refer to Section F. for hazardous situations that will apply to the general use of this wheelchair.







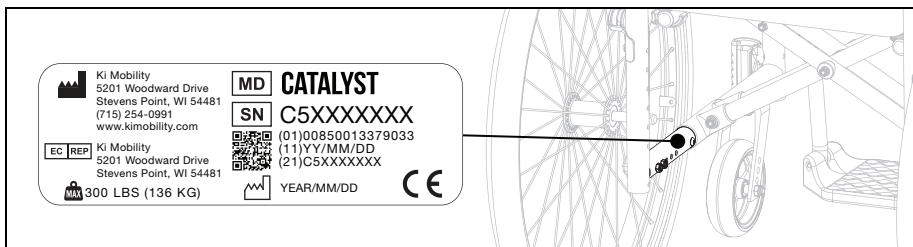





III. NOTICE - READ BEFORE USE

D. Serial Number Identification

The serial number label provides important information about your chair and the serial number is used as the unique identifier for your specific chair. See image below on where to find the serial number on your chair.



E. Symbol Glossary

SYMBOL	DEFINITION
	Indicates the medical device manufacturer.
	Date of manufacture (YEAR/MM/DD).
	Indicates the need for the user to consult an instruction for safety reasons such as cautions and warnings. If presented on the medical device or packaging, it indicates the need for the user to consult the instructions for safety reasons such as cautions and warnings.
	Indicates the item is a medical device.
	Indicates the manufacturer's serial number so that a specific medical device can be identified.
	Indicates the authorized representative in the European Community.
	Indicates the manufacturer's declaration that the product meets the requirements of the applicable EC directives.
	Indicates the need for the user to consult the instructions for use.
	Indicates the need for the user to consult the listed website for instructions for use in an electronic format.
	Indicates a website where a user may obtain additional information about the medical product.
	Indicates a specified maximum weight limit (lbs/kg).
	Indicates a transit securement point.
	Indicates a potential pinch point.









III. NOTICE - READ BEFORE USE

F. General Warnings and Cautions

WARNING

	Standard	HD
Catalyst 5Vx	300 lbs (136 kg)	350 lbs (159 kg)

WARNING: Limits refer to combined weight in pounds of user and all items carried. Do not exceed weight limit of chair. Exceeding weight limit may damage your chair or may increase your risk of falling or tipping over. A tip-over or fall could result in serious injury or death.

-  Do not use chair for weight training. The movement of the additional weight alters the chair's center of gravity increasing your risk of tipping over. A tip-over could result in damage to your chair or in serious injury or death.
-  Keep tires inflated to correct tire pressure. Using a chair without properly inflated tires may affect its stability, increasing your risk of tipping over. A tip-over could result in damage to your chair or in serious injury or death to you or others. Correct tire pressure is indicated on the side wall of the tire. Your wheelchair provider can determine if your tires are inflatable if you are unsure.
-  Avoid ramps or slopes inclined more than 9 degrees. Steep slopes increase your risk of falling or tipping over. A tip-over or fall could result in damage to your chair or in serious injury or death to you or others. Do not use chair on ramps or slopes tilted more than 9 degrees (about 2 inches rise/drop per linear-foot): neither up/down nor across.
-  Avoid inclined surfaces slick or coated with ice, oil or water. Slippery inclines could result in an inability to control the wheelchair on the surface and result in a tip-over or fall. A tip-over or fall could result in damage to your chair or in serious injury or death.
-  Avoid leaning over the side or back of your wheelchair to extend your reach. Leaning over chair could change its center of gravity and cause an unstable situation resulting in a fall or tip-over. A tip-over or fall could result in damage to your chair or in serious injury or death.
-  Do not lift wheelchair by its removable parts while occupied. Lifting a wheelchair by removable parts while occupied could cause user to fall or lose control. A fall or loss of control could result in damage to your chair or in serious injury or death.
-  Packaging material must be kept out of the reach of children. Improper handling of packaging materials and the neglect of the duty to supervise children could result in suffocation and serious injury or death.
-  Do not expose the chair and components to any extreme temperatures (e.g. sunlight, sauna, extreme cold). Hypothermia or burns through contact with the chair and components can occur and/or failure of components.

CAUTION

CAUTION: Avoid overtightening bolts and hardware that attach components to the frame. Overtightening could cause damage to the chair; affecting its durability and performance. Damage to the chair could result in injury to the user.

NOTE: Information about tightening hardware can be found in the maintenance section of this manual. If you are unsure how to properly tighten bolts or hardware or lack the tools necessary, consult your authorized supplier.

III. NOTICE - READ BEFORE USE

G. Positioning Belts or Harnesses

WARNING

WARNING: Improper use of positioning belts can cause the user to slide underneath the positioning belt in the wheelchair. If this should happen, chest compression or suffocation due to pressure from the belt can occur. If this occurs, the user's breathing may be hampered causing serious injury or death.



Improper use of positioning belts could cause body parts to become entangled which can restrict mobility and movement, which could result in serious injury or death.

Ki Mobility recommends the use of pelvic positioning belts. Pelvic positioning belts can reduce the risk of falling from your wheelchair.

Positioning belts, such as pelvic positioning belts and anterior trunk harnesses and straps, are designed to assist, retain and support proper positioning and posture in the wheelchair.

- Ensure the user does not slide underneath the positioning belt in the wheelchair seat.
- The positioning belt should have a snug fit; tight enough to hold their position, but not so tight as to restrict breathing. An open hand should be able to fit between the belt and the user.
- Proper use of cushions can contribute to pelvic stability and reduce sliding.
- NEVER Use Positioning Belts:
 - a. As a restraint. A restraint requires a doctor's order.
 - i. Unless you can remove the belts easily in an emergency. If you cannot do this, consult with your health care advisor for other options to help with your posture.
 - b. On a user who is unconscious or agitated.
 - c. As an occupant restraint or safety belt in a motor vehicle. A positioning belt is not designed to replace a seat belt that is attached to the frame of a vehicle, which would be required of an effective seat belt. During a sudden stop, with the force of the stop, the user would be thrown forward. Wheelchair seat belts will not prevent this, and further injury may result from the belts or straps. Reference Transit section of this manual for further information.

H. Riding Your Wheelchair

WARNING









WARNING: Avoid pushing or using your wheelchair on soft, rough, uneven, or slick surfaces (including but not limited to ice, sand, loose soil, grass, gravel, potholes, cracks, and broken pavement). Use on such surfaces could cause the wheelchair to lose stability causing it to tip unexpectedly resulting in a fall or loss of control. A fall or loss of control could result in damage to your wheelchair, serious injury or death.



Always look ahead for potential obstructions or surface transitions that could cause your front caster wheels to catch causing your wheelchair to abruptly stop. Failure to do so could cause the wheelchair to tip unexpectedly resulting in a fall or loss of control. A fall or loss of control could result in damage to your wheelchair, serious injury or death.

III. NOTICE - READ BEFORE USE

H. Riding Your Wheelchair (Continued)

-  Always look ahead for objects or obstructions that your wheelchair could potentially strike. Striking an object or obstruction could cause your wheelchair to tip unexpectedly resulting in a fall or loss of control. A fall or loss of control could result in damage to your wheelchair, serious injury or death. In addition, striking an object or obstruction could cause damage to your wheelchair. The risk of injuries and damage to your wheelchair when striking an object or obstruction increases with your rate of speed.
-  Using your wheelchair on public roads is extremely hazardous and is not recommended. Wheelchair users must obey pedestrian traffic rules. Review the traffic laws in your own state, some states do not permit wheelchair use on public roads.
-  Your balance is affected by the slope of the surfaces you ride on. Because balance is affected, your wheelchair will be less stable when it is at an angle. This is especially true when riding on a slope sideways. Riding your wheelchair on a slope could cause the wheelchair to tip unexpectedly and/or the user to lose stability resulting in a fall or loss of control. A fall or loss of control could result in damage to your wheelchair, serious injury or death.
-  When using your wheelchair in public or private areas (including but not limited to crosswalks, sidewalks, neighborhoods, parking lots and parks) be alert to the danger of motor vehicles. Due to your low position:
 - When lighting is poor use reflective tape on your wheelchair and clothing.
 - If you have the right-of-way always yield until the driver of the motor vehicle has seen you.
-  Use extreme caution when propelling backward. You may be unable to see an obstruction that could cause a tip over. Tipping over could result in damage to your wheelchair, serious injury or death.
-  Ki Mobility does not recommend balancing on just the rear wheels with the front casters off the ground (also known as doing a “wheelie”). A fall or tip over is very likely and could result in damage to your wheelchair, serious injury or death. If you choose to ignore this warning, do not attempt a wheelie unless you have been trained by a clinical or technical professional. You should always have the assistance of an able-bodied person prepared to prevent you from exceeding your tipping point.
-  Do not ride your wheelchair on an escalator. Use of a wheelchair on an escalator could cause a fall, tip-over or loss of control. A fall, tip over or loss of control could result in damage to your wheelchair, severe injury or death.
-  Avoid getting dressed or undressed in your wheelchair. Dressing or undressing in your wheelchair causes your weight to shift. Thus, increasing your risk of falling or tipping over. Falling or tipping over could result in damage to your wheelchair, serious injury or death.
-  Ki Mobility recommends using accessories such as heel loops and calf straps. When used properly, heel loops and calf straps can aid in preventing your legs and feet from accidentally slipping off the footplate or footrest potentially causing your feet to become entangled in the wheelchair and its components or strike the ground. Use of a wheelchair without accessories such as properly fitted heel loops and calf straps can result in a potentially hazardous situation which, if not avoided, could result in injury.

III. NOTICE - READ BEFORE USE

H. Riding Your Wheelchair (Continued)

When using your wheelchair always:

- Scan the area well ahead of your wheelchair as you ride.
- Ensure the surfaces you ride on are level and free of obstacles.
- Remove or cover threshold strips between rooms.
- If your wheelchair has anti-tips make sure they are locked in place when riding your wheelchair (Reference IV, S. for proper use of anti-tips).
- Keep both of your hands on the handrims as you go over obstacles.
- Never push or pull off an object to propel your wheelchair.
- Make sure there is not a drop off at the bottom of ramps.
- On an up-slope, lean your upper body forward slightly to prevent tipping backwards.
- On a down-slope, press your upper body backwards to prevent tipping forward.
- Do not attempt to push over obstacles without assistance.
- Ensure all ramps, slopes or curb cuts you attempt to ride on are compliant with ADA (Americans with Disabilities Act) guidelines or the equivalent accessibility guidelines in your region.

ADA Guidelines and more information about accessible design are available at: www.ada.gov

I. Power Drives

WARNING

WARNING: Ensure the power drive system has been validated and approved by the manufacturer for use with your Ki wheelchair and its configuration. Use of an unapproved external power drive system could result in mechanical failure of the wheelchair or cause a fall. A fall could result in damage to your wheelchair, severe injury or death.



Power drive systems change the stability and performance of the wheelchair. Always use anti-tips with your power drive system. Failure to do so could result in your wheelchair tipping over backwards. Tipping over backwards could result in damage to your wheelchair, severe injury or death.



Always look ahead for objects or obstructions that your wheelchair could potentially strike. Power drive systems change the performance of the wheelchair and will increase the risk of tipping unexpectedly if you strike an object or obstruction. Tipping unexpectedly could result in a fall or loss of control. A fall or loss of control could result in damage to your wheelchair. The risk of injuries and damage to your wheelchair when striking an object or obstruction increases with your rate of speed.

Ki Mobility does not recommend the installation of power drive systems on any Ki Mobility wheelchair. Ki Mobility wheelchairs have not been designed or tested by Ki Mobility as power wheelchairs. If you add a power drive system to a Ki Mobility wheelchair, be sure the manufacturer of the power drive system has validated and approved the combination of the power drive system and wheelchair as safe and effective.

III. NOTICE - READ BEFORE USE

J. Your Wheelchair and the Environment

CAUTION

CAUTION: Exposure to water or excessive moisture may cause the metal in the wheelchair to rust or corrode and the fabric to tear. Dry your chair as soon as possible if exposed to water.

 **DO NOT USE YOUR WHEELCHAIR IN A SHOWER, POOL OR BODY OF WATER.** This will cause your wheelchair to rust or corrode and eventually fail.

 **Do not operate your wheelchair in sand.** Sand can get into the wheel bearings and moving parts. This will cause damage and eventually will cause the wheelchair to fail.

K. Modifying your Wheelchair

WARNING

WARNING: NO ONE SHOULD MODIFY THIS WHEELCHAIR EXCEPT BY ADJUSTING IT ACCORDING TO THIS MANUAL OR BY ADDING KI MOBILITY APPROVED OPTIONS. THERE ARE NO APPROVED OPTIONS THAT INVOLVE DRILLING OR CUTTING THE FRAME BY ANYONE OTHER THAN A TRAINED KI MOBILITY ASSOCIATE. Your wheelchair was engineered and manufactured under strict design controls. An integral part of this process is ensuring the various components work together correctly; they have been tested to various standards to ensure quality and are approved to work together. Contact an authorized supplier or Ki Mobility before adding any accessories or components not provided by Ki Mobility. Unapproved modifications or options could lead to fall and cause serious injury or death.

L. Wheelchair Stability

WARNING

WARNING: The stability of your wheelchair could be affected when using on soft, rough, uneven (incline or decline), or slick surfaces (including but not limited to ice, sand, loose soil, grass, gravel, potholes, cracks, and broken pavement). Use on such surfaces could cause the wheelchair to tip unexpectedly resulting in a fall or loss of control. A fall or loss of control could result in damage to your wheelchair, serious injury or death.

 **Shifting weight in your wheelchair, adding weight to your wheelchair and carry or reaching for objects could affect the stability of your wheelchair.** Thus, increasing your risk of falling or tipping over. Falling or tipping over could result in damage to your wheelchair, serious injury or death.

 **Avoid getting dressed or undressed in your wheelchair.** Dressing or undressing in your wheelchair causes your weight to shift. Thus, increasing your risk of falling or tipping over. Falling or tipping over could result in damage to your wheelchair, serious injury or death.

 **Ki Mobility does not recommend balancing on just the rear wheels with the front casters off the ground (also known as doing a "wheelie").** A fall or tip over is very likely and could result in damage to your wheelchair, serious injury or death. If you choose to ignore this warning, do not attempt a wheelie unless you have been trained by a clinical or technical professional. You should always have the assistance of an able-bodied person prepared to prevent you from exceeding your tipping point.

III. NOTICE - READ BEFORE USE

L. Wheelchair Stability (Continued)

WARNING

WARNING: If the wheelchair is equipped with a system to vary the tilt angle of the seat frame, confirm it is stable throughout the range of angle changes before use. If the wheelchair is not stable throughout the range of tilt angles a fall or tip over is imminent. Falling or tipping over could result in damage to your wheelchair, serious injury or death.

Strategies to minimize the risk of falling:

- Ensure anti-tips are in the correct position (Reference IV, S. for proper use of anti-tips).
- Lean forward when pushing up an incline.
- Lean back when pushing down a decline.
- Have an attendant behind you to provide assistance.
- Wheelchair set up should be done only by an authorized technician.
- Always use the accessories provided.
- Your wheelchair should be adjusted by an authorized technician when there are changes in your weight or how you sit.
- Always use anti-tips where appropriate (Reference IV, S. for proper use of anti-tips).

To ensure proper stability of your wheelchair, you must make sure the center of gravity and the wheelchair's base of support is correct for your balance and abilities. Many factors can affect these two elements:

- Seat height
- Seat depth
- Back angle
- Seat angle
- Size and position of rear wheels
- Size and position of front casters
- Seating system components
- Tilt position (If applicable)

There are additional actions that can have adverse effects on the stability of your wheelchair. You should consult with an assistive technology professional or clinical professional that is familiar with your needs and capabilities to determine what you are able to do safely while maintaining the stability of your wheelchair.

M. Aftermarket Seating

WARNING

WARNING: The installation of a cushion on a wheelchair could affect the center of gravity of the wheelchair. Changes in your center of gravity may affect your stability in your wheelchair, resulting in tipping over or falling from your wheelchair which may result in serious injury. Always review the instructions for use of your wheelchair to see if changes to the wheelchair may be needed to provide sufficient stability after adding a cushion.



The integrity of your skin can be affected by many aspects of your daily life and medical condition, including the use of this product. Be sure to follow any skin care regimens established by your clinician. Consumers of this product should make sure their skin is inspected routinely for changes as directed by their clinician. Failure to do so could result in serious injury or death.

Selecting the Proper Seating Product

You should consult with a licensed clinician (i.e. Physician or therapist) trained in wheelchair seating and positioning before selecting any seating and positioning product. This will help ensure you receive the right product for your specific needs.

IV. WHEELCHAIR USE & CONFIGURATION

A. Ascending Stairs



WARNING: Do not ascend stairs without the assistance of at least two people who are trained on the below steps and are able to handle the weight of you and the wheelchair. Ascending stairs can be challenging and may result in a fall that could result in damage to your wheelchair, serious injury or death to the user and/or those assisting.

NOTE: When ascending a set of stairs the user should be facing the bottom of the stairs.

1. Remove or turn the anti-tips up when ascending stairs. Always remember to reinstall or turn the anti-tips to the down position after they were removed or turned to the up position. If the anti-tips are left in the down position when ascending stairs, they can be bent or broken. If the anti-tips are bent or broken, they will no longer prevent the wheelchair from tipping over backwards. Tipping over backwards could result in damage to your chair, serious injury or death.
2. Position one person behind the user and one person in front. The person in front and back must hold on to a non-removable part of the wheelchair.
3. The person behind the user tilts the wheelchair back and both attendants lift together. Take one step at a time.

B. Descending Stairs



WARNING: Do not descend stairs without the assistance of at least two people who are trained on the below steps and are able to handle the weight of you and the wheelchair. Descending stairs can be challenging and may result in damage to your wheelchair, serious injury or death to the user and/or those assisting.

NOTE: When descending stairs, the user should be facing the top of the stairs.

1. Remove or turn the anti-tips up when descending stairs. Always remember to reinstall or turn the anti-tips to the down position after they were removed or turned to the up position. If the anti-tips are left in the down position when descending stairs, they can be bent or broken. If the anti-tips are bent or broken, they will no longer prevent the wheelchair from tipping over backwards. Tipping over backwards could result in damage to your chair, serious injury or death.
2. Position one person behind the user and one person in front. The person in front and back must hold on to a non-removable part of the wheelchair.
3. The person behind the user tilts the chair backward and guides the wheelchair down the stairs slow and one step at a time on the rear wheels of the chair.

IV. WHEELCHAIR USE & CONFIGURATION

C. Transfers



WARNING: Be trained and ensure that you can transfer on your own or with a person who can assist you. It is dangerous to transfer on your own as it requires good balance and agility. Be aware there is a point during every transfer when the wheelchair seat is not below you. Failure to perform a transfer properly can result in a fall that could result in severe injury or death.

NOTE: Before transferring out of your wheelchair every caution should be taken to reduce the gap between the two surfaces.

1. Engage the wheel locks to lock the rear wheels.
2. Rotate the casters forward to increase the wheelbase of the wheelchair.
3. Remove or swing away the footrests.
4. Have someone assist you unless you are well experienced and able in transfers.

D. Transit Use



WARNING: Never use your wheelchair as a seat in a motor vehicle unless it has been equipped with the transit option. It is always safest to transfer out of your wheelchair onto a seat in a motor vehicle with appropriate seat and shoulder belts. Using your wheelchair as a seat in a motor vehicle, if not equipped with the transit option, could result in serious injury or death.

The wheelchair equipped with the transit option has been tested to and passed the RESNA WC-4, Section 19: Wheelchairs used as seats in motor vehicles and ISO 7176-19 Wheelchairs -- Part 19: Wheeled mobility devices for use as seats in motor vehicles. RESNA and ISO standards are designed to test the structural integrity of the wheelchair as a seat for use in a motor vehicle. These standards are also designed to create compatibility with Wheelchair Tie-down and Occupant Restraint Systems (WTORS).

Not every wheelchair configuration is compatible with the transit option. Ki Mobility manages the configuration and does not offer this wheelchair except in compatible configurations. If you make changes to your wheelchair after you receive it, you should contact your wheelchair provider or Ki Mobility to make sure it is appropriate to continue to use your wheelchair as a seat in a motor vehicle.

Aftermarket seating may have replaced the original equipment seat and back support designed and tested as part of the transit option. Your wheelchair provider should tell you if the seating they provided is original equipment or replacement aftermarket seating. A complete system of wheelchair frame, seating, Wheelchair Tie-down and Occupant Restraint Systems and a properly equipped motor vehicle, that have all complied with the standards mentioned in this section, should be in place before using a wheelchair equipped with the transit option as a seat in a motor vehicle.

When using your wheelchair as a seat in a motor vehicle you should always observe the following instructions:

IV. WHEELCHAIR USE & CONFIGURATION

D. Transit Use (Continued)

- The rider must be in a forward-facing position.
- The rider and all items carried must not weigh more than 300 lbs (136 kg).
- Backpacks and pouches should be removed and secured separately in the motor vehicle. In the event of an accident these items can become dangerous projectiles, which may injure or kill you or other occupants of the motor vehicle.
- The rider must use a Wheelchair Tie-down and Occupant Restraint System that complies with RESNA WC-4, Section 18: Wheelchair tie-down and occupant restraint systems for use in motor vehicles or ISO 10542-1 Technical systems and aids for disabled or handicapped persons -- Wheelchair tie-down and occupant-restraint systems -- Part 1: Requirements and test methods for all systems.
- Attach the wheelchair tie-downs to the four securement points (two front, two rear) on the wheelchair with the transit option (Fig. 1) in accordance with the wheelchair tie-down manufacturer's instructions and RESNA WC-4, Section 18 or ISO 10542-1, - Part 1.

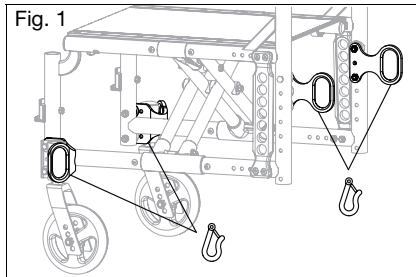

- Attach occupant restraints in accordance with the occupant restraint manufacturer's instructions and RESNA WC-4, Section 18 or ISO 10542-1, Part 1.
- Use of lap belts, chest straps, shoulder harnesses, any other positioning strap system or positioning accessory should not be used, or relied on as an occupant restraint, unless it is marked as such by the manufacturer in accordance with RESNA WC-4, Section 18 or ISO 10542-1, Part 1.
- Use of headrests, lateral supports or other positioning accessories should not be used, or relied on as an occupant restraint, unless it is marked as such by the manufacturer in accordance with RESNA WC-4, Section 18 or ISO 10542-1, Part 1 or RESNA WC-4, Section 20: Wheelchair seating systems for use in motor vehicles or ISO 16840-4 Wheelchair seating -- Part 4: Seating systems for use in motor vehicles.
- After being fitted and adjusted, the top of the original equipment back upholstery should be within 4 inches (10,16 cm) of the top of your shoulder.
- Any aftermarket seating should be tested to comply with RESNA WC-4, Section 20 or ISO 16840-4 - Part 4.
- Attach the seating to the wheelchair frame in accordance with the seating manufacturer's instructions and RESNA WC-4, Section 20 or ISO 16840-4 - Part 4.
- Aftermarket accessories such as trays, oxygen tank holders, oxygen tanks, IV poles, back packs, pouches and items not manufactured by Ki Mobility should be removed and secured separately in the motor vehicle. In the event of an accident, these items can become dangerous projectiles which may injure or kill you or other occupants of the motor vehicle.
- If the wheelchair has been involved in an accident, you should not continue to use it, as it may have suffered fatigue, or damage, that may not be visible.

IV. WHEELCHAIR USE & CONFIGURATION

D. Transit Use (Continued)



WARNING: Remove and secure any items temporarily attached to the chair while in a motor vehicle. Leaving items attached to the vent tray, battery tray or oxygen tank holder and not securing them properly and separately in a motor vehicle could result in these items becoming dangerous projectiles in the event of an accident. Additionally, oxygen tanks contain a highly pressurized gas that vigorously accelerates combustion. These factors could lead to serious injury or death to the user and/or anyone else in the vehicle.

- When using this wheelchair as a seat in a motor vehicle, you must remove any items attached to the vent tray, battery tray or oxygen tank holder and properly secure them separately.
- If the chair is equipped with an oxygen tank holder never use the wheelchair as a seat in a motor vehicle.

NOTE: To obtain copies of RESNA or ISO standards please contact the standards organizations below:

RESNA

www.resna.org

ANSI/RESNA Standards:

RESNA WC-4, Section 18:

Wheelchair tie-down and occupant restraint systems for use in motor vehicles.

RESNA WC-4, Section 19:

Wheelchairs used as seats in motor vehicles.

RESNA WC-4, Section 20:

Wheelchair seating systems for use in motor vehicles.

International Organization for Standardization (ISO)

www.iso.org

ISO Standards:

ISO 10542-1: Technical systems and aids for disabled or handicapped persons --

Wheelchair tie-down and occupant-restraint systems -- Part 1:

Requirements and test methods for all systems.

ISO 16840-4: Wheelchair seating – Part 4:

Seating systems for use in motor vehicles.

ISO 7176-19: Wheelchairs – Part 19:

Wheeled mobility devices for use as seats in motor vehicles.

IV. WHEELCHAIR USE & CONFIGURATION

E. Cushion Use

WARNING

WARNING: Avoid sitting for long periods of time without a proper wheelchair cushion. Sitting for long periods of time without a proper wheelchair cushion could cause pressure ulcers which could lead to serious infections or even death.

 **Secure the cushion before use or transfer. Failure to secure a cushion can cause it to slide out during use or transfers, resulting in a fall or loss of control. A fall or loss of control could result in damage to your chair or in serious injury or death to you or others.**

- a. This wheelchair was designed to be used with a proper wheelchair cushion.
- b. The standard sling upholstery is provided with hook and loop self fastening strips. The cushion being used should have hook type fasteners that can engage the loop of the seat sling to keep the cushion from sliding out from under you. Ensure the cushion is securely attached before transferring or sitting in the wheelchair.
- c. A standard seat sling may not have been provided with your chair. Check with your wheelchair provider if an aftermarket replacement to the original equipment sling has been provided. If so, make sure you follow the instructions for use provided by the aftermarket manufacturer.

IV. WHEELCHAIR USE & CONFIGURATION

F. Your Catalyst 5Vx & Its Parts

1. Inspect and maintain your chair using information found in the Maintenance and Care section.
2. If you detect a problem, contact your authorized supplier immediately.

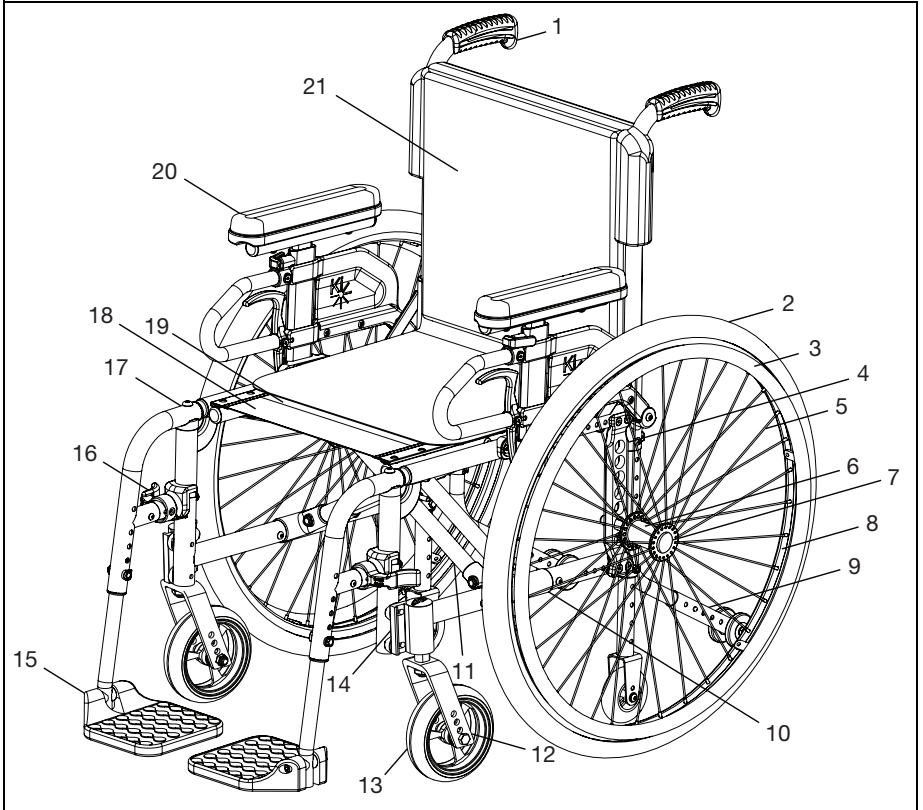

- | | |
|------------------------------|---|
| 1. Push Handle Backrest Tube | 12. Caster Fork |
| 2. Pneumatic Tire | 13. Caster Wheel |
| 3. Aluminum Handrim | 14. Caster Housing |
| 4. Axle Plate | 15. Flip-Up Composite Footrest |
| 5. Spokes | 16. Swing-Away Latch Release |
| 6. Rear Wheel Hub | 17. Swing-Away Footrest/ Footrest |
| 7. Quick-Release Axle | 18. Seat Sling |
| 8. Aluminum Wheel Rim | 19. Lifting Strap |
| 9. Anti-Tip | 20. Flip Back Height Adjustable Armrest |
| 10. Rear Frame Component | 21. Backrest |
| 11. Cross Brace | |

IV. WHEELCHAIR USE & CONFIGURATION

G. Height Adjustable T-Arm

WARNING

WARNING: These arms offer only a lock against rotation and are designed to bear a downward force only. They will remove completely if pulled up on and cannot be used to lift or otherwise handle the chair. Failure to comply with the instructions above may result in the armrest accidentally disconnecting from the wheelchair and result in a fall or loss of control and may cause serious injury or death.

How to Use Your Armrest

1. Installation
 - a. Slide the outer armpost into the receiver mounted to the wheelchair frame.
 - b. The armrest will automatically lock into place. Check to make sure the locking lever is as shown (Fig. 2:B).
2. Height Adjustment
 - a. Rotate the release lever (Fig. 2:A).
 - b. Slide the armrest pad up or down to the desired height.
 - c. Return the lever to the locked position against the arm post.
 - d. Push the arm pad until the upper arm locks firmly into place. Check to make sure the locking lever is as shown (Fig. 2:A).
3. Removing the Armrest
 - a. Squeeze the release lever (Fig. 2:B) and remove the armrest.

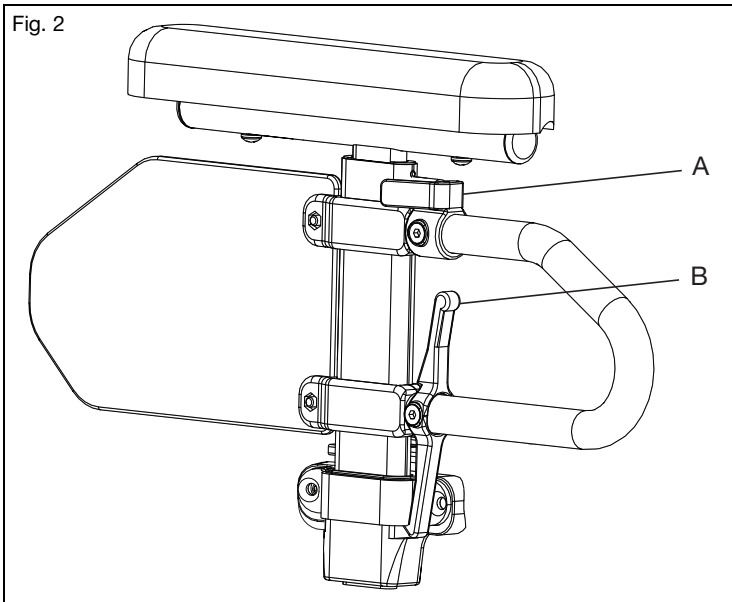

IV. WHEELCHAIR USE & CONFIGURATION

H. Swing Away Armrests

WARNING

WARNING: These arms offer only a lock against rotation and are designed to bear a downward force only. They will remove completely if pulled up on and cannot be used to lift or otherwise handle the chair. Failure to comply with the instructions above may result in the armrest accidentally disconnecting from the wheelchair and result in a fall or loss of control and may cause serious injury or death.

How to Use Your Armrest

1. Installation (Fig. 3)
 - a. Slide the armrest into the tube of the receiver that is mounted on the rear side of the frame.
2. Swinging the Arm
 - a. Lift the armrest slightly so it is free of the receiver bolt. Rotate away from the chair.
3. Removing the Armrest
 - a. Lift the armrest straight out of the receiver.

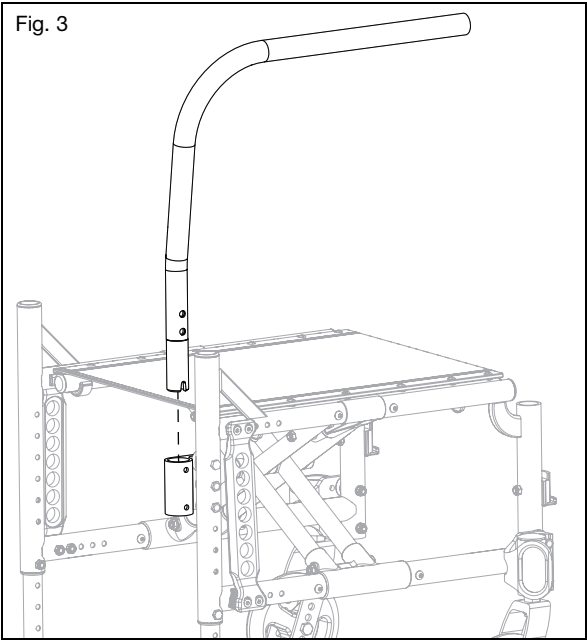

IV. WHEELCHAIR USE & CONFIGURATION

I. Height Adjustable Flip Back T-Arm

⚠️ WARNING ⚠️

WARNING: These arms offer only a lock against rotation and are designed to bear a downward force only. They will remove completely if pulled up on and cannot be used to lift or otherwise handle the chair. Failure to comply with the instructions above may result in the armrest accidentally disconnecting from the wheelchair and result in a fall or loss of control and may cause serious injury or death.

How to Use Your Armrest

1. Flipping the Armrest

The tension felt during the flipping of the armrest can be decreased or increased by tightening or loosening the bolt (Fig. 4:B).

- a. To flip back the armrest, pull the release lever (Fig. 4:A) up and lift the armrest assembly up and back.
- b. To return the armrest down, lower the armrest assembly until the release lever locks back into place.

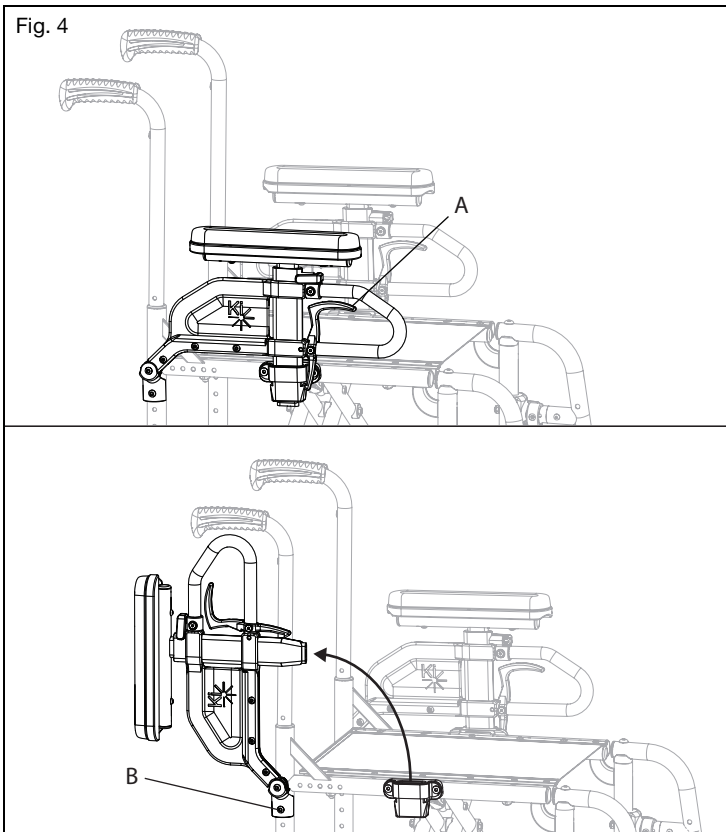

IV. WHEELCHAIR USE & CONFIGURATION

I. Height Adjustable Flip Back T-Arm (Continued)

2. Increase/Decrease the Front End Length of Armrest

The armrest pad is not centered on the tube, widthwise or lengthwise. This offers two different length options - longer or shorter on the front end of the chair. This also offers two options with the armrest pad. When the long end of the armrest is on the front end of the chair, the armrest pad hangs more to the outside of the chair. The armrest pad hangs more to the inside of the chair when the short end of pad is on the front end of chair. The armrests can also be switched to the opposite sides to allow more options regarding the amount of front end pad length and side pad length.

- a. Pull the height adjustment lever (Fig. 5:A) and remove the upper T-Arm assembly (Fig. 5:B).
- b. Rotate the upper T-Arm assembly and reinstall into the armrest.
- c. Close the height adjustment lever (Fig. 5:A) to secure.

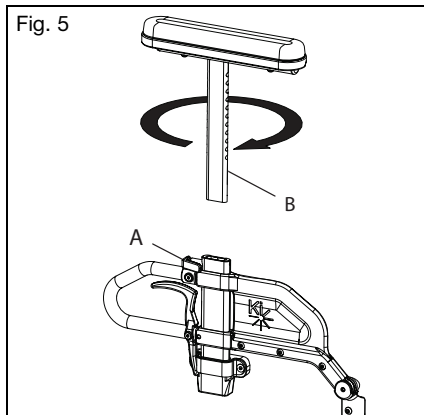

3. Increase/Decrease the Height of the Armrest

Each hole on the upper T-Arm assembly bar represents a height setting that can be used $\frac{1}{2}$ " (1,27 cm) increments.

- a. Pull the height adjustment lever (Fig. 6:A) and slide the upper T-Arm assembly to the desired height.
- b. Close the height adjustment lever (Fig. 6:A) to secure.

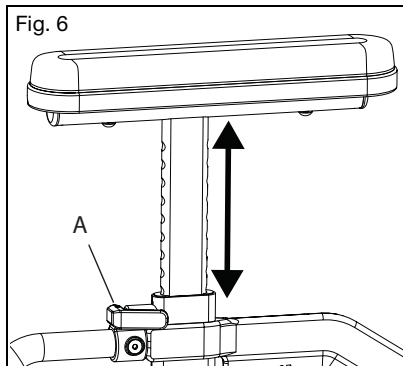

IV. WHEELCHAIR USE & CONFIGURATION

J. Swing Away Hangers

WARNING

WARNING: Ensure the hangers are locked into place before using or riding the wheelchair. Unlocked hangers during use can cause a fall resulting in serious injury or death.

 **Avoid tripping or falling during a transfer. Ensure your feet do not get caught in the space between the footrests and avoid putting weight on the footrests as the chair may tip forward and cause a fall resulting in a serious injury or death.**

How to Use Your Hangers

1. Installation
 - a. Place swing away pivot saddle into the receiver on the front frame tube with the footrest facing either inward or outward from the frame (Fig. 7:A).
 - b. Rotate the footrest so it aligns with the frame and locks into place in the latch block (Fig. 7:B).
2. Swinging the Footrest Away
 - a. Push the release latch toward the frame.
 - b. Rotate the footrest outward or inward as desired.
3. Removal
 - a. To remove the footrest, push the release latch toward the frame.
 - b. Lift the footrest straight upward to remove. You may also swing the footrest inward or outward before lifting it off.

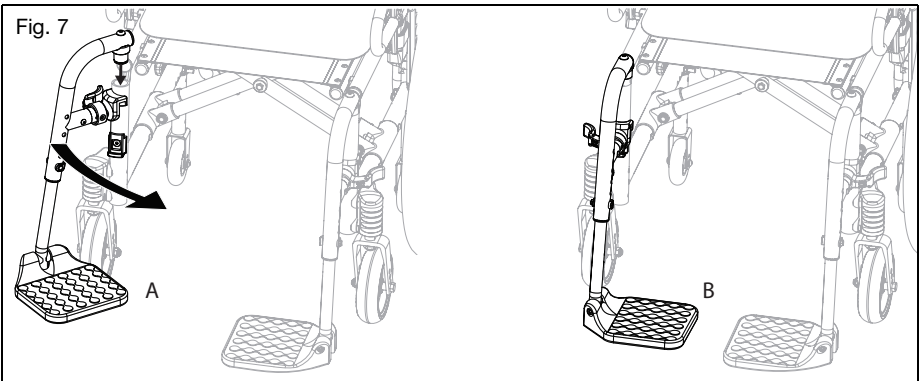

IV. WHEELCHAIR USE & CONFIGURATION

K. Swing Away Hangers with 4-Way Latch

WARNING

WARNING: Ensure hangers are locked in place before using wheelchair. Unlocked hangers while using the wheelchair could cause a fall resulting in serious injury or death.

 **Avoid tripping or falling during a transfer. Ensure your feet do not get caught in the space between the footrests and avoid putting weight on the footrests as the chair may tip forward and cause a fall resulting in a serious injury or death.**

How to Use Your Hangers with 4-Way Latch

1. Installation
 - a. Place the swing away pivot saddle into the receiver on the front frame tube (Fig. 8:A)
 - b. Rotate the footrest so that it aligns with the frame and locks into place in the latch block (Fig. 8:B).
2. Swinging the Footrest Away
 - a. Push or pull on the release latch.
 - b. Rotate the footrest outward or inward as desired.
3. Removal
 - a. To remove the footrest, push or pull the release latch.
 - b. Lift the footrest straight upward to remove. You may also swing the footrest inward or outward before lifting it off.

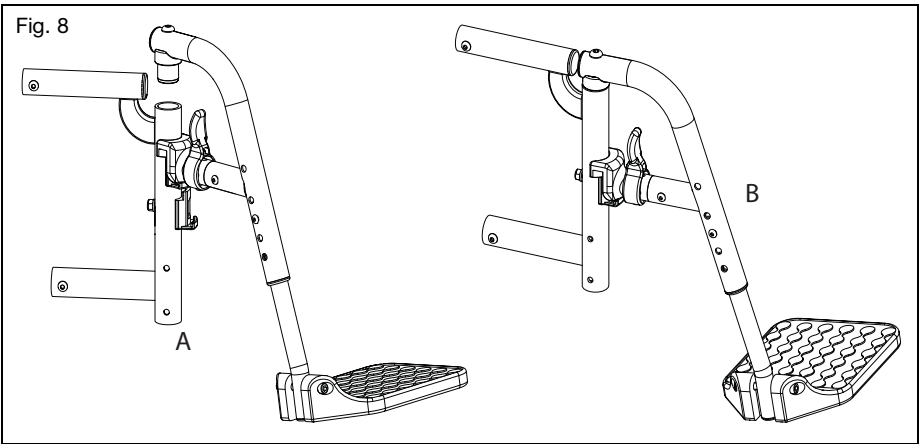

IV. WHEELCHAIR USE & CONFIGURATION

L. Extension Tubes

WARNING

WARNING: Ensure hangers are locked into place before using or riding the wheelchair. Unlocked hangers during use can cause a fall resulting in serious injury or death.

How to Adjust the Extension Tubes (Fig. 9)

1. Remove the mounting fasteners from each side of the hanger tube.
2. Slide the footrest extension tube to the desired height.
3. Line up the holes and reassemble the fasteners into the desired hole through the hanger and the extension tube.
4. Repeat steps 1 - 3 on opposite side.

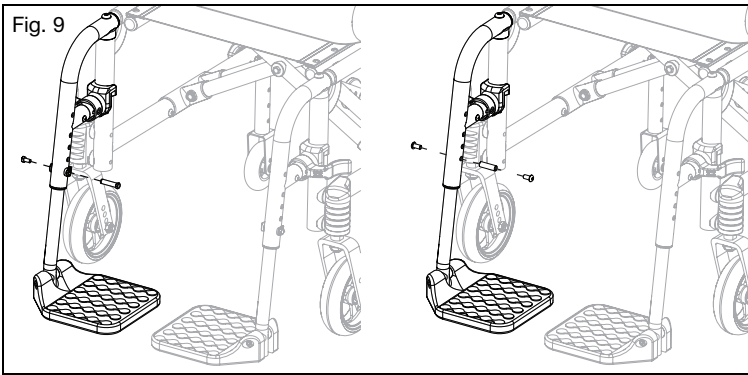

M. Elevating Leg Rest

WARNING

WARNING: Ensure hangers are locked in place before using wheelchair. Unlocked hangers while using the wheelchair could cause a fall resulting in serious injury or death.

 **Avoid tripping or falling during a transfer. Ensure your feet do not get caught in the space between the footrests and avoid putting weight on the footrests as the chair may tip forward and cause a fall resulting in a serious injury or death.**

How to Use the Elevating Leg Rest

1. Installing the Elevating Leg Rest
 - a. Place the swing away pivot saddle into the receiver on the front frame tube with the footrest facing either inward or outward from the frame. Similar to the swing away footrest pictured in Fig. 8.
 - b. Rotate the footrest so it aligns with the frame until it locks into place in the latch block.
2. Removing the Elevating Leg Rest
 - a. To remove the footrest, push or pull the release lever.
 - b. Rotate the footrest outward and lift.

IV. WHEELCHAIR USE & CONFIGURATION

M. Elevating Leg Rest (Continued)

3. Adjusting the Extension Tube
 - a. Remove the mounting bolt that is threaded into the leg rest tube in the center of the pad bracket (Fig. 10:C). In some circumstances, this bolt may be inserted in the tube below the pivot bracket.
 - b. Slide the footrest extension tube to the desired height.
 - c. Line up the holes and replace the bolt through the leg rest tube and the extension tube.
 - d. Repeat steps a - c on opposite side.
4. Adjusting the Angle of the Leg Rest
 - a. To raise, lift up on the rear of the extension tube (Fig. 10:A). The rod will slide through the ratchet in this direction. Stop at the desired position.
 - b. To lower, firmly hold the leg from behind the extension tube (Fig. 10:A). Pull forward on the lever (Fig. 10:B) and while holding the lever, lift the leg rest. Releasing the lever will cause the leg rest to lock into position.

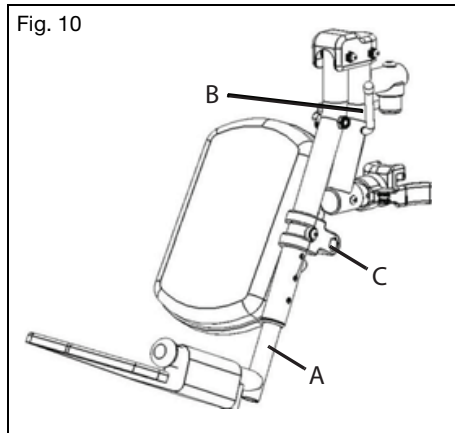

N. Pro Elevating Leg Rest

⚠ WARNING ⚠

WARNING: Ensure hangers are locked in place before using wheelchair. Unlocked hangers while using the wheelchair could cause a fall resulting in serious injury or death.



Avoid tripping or falling during a transfer. Ensure your feet do not get caught in the space between the footrests and avoid putting weight on the footrests as the chair may tip forward and cause a fall resulting in a serious injury or death.

How to Use the Pro Elevating Leg Rest

1. Installing the Pro Elevating Leg Rest
 - a. Place the swing away pivot saddle into the receiver on the front frame tube with the leg rest facing either inward or outward from the frame. Similar to the swing away footrest pictured in Fig. 8.
 - b. Rotate the leg rest so that it aligns with the frame and locks into place in the latch block.

IV. WHEELCHAIR USE & CONFIGURATION

N. Pro Elevating Leg Rest (Continued)

2. Adjusting the Height of the Calf Pad
 - a. Loosen nut (Fig. 11:A) using a 10mm wrench.
 - b. Slide the calf pad arm up or down to the desired location.
 - c. Retighten the nut.
3. Adjusting the Depth of the Calf Pad
 - a. Remove the screw (Fig 11:B) and nut (Fig. 11:C) on the calf pad arm using a 5mm Allen wrench and a 13mm wrench.
 - b. Pick the desired location based on the four predrilled holes and reinstall the screw and nut.

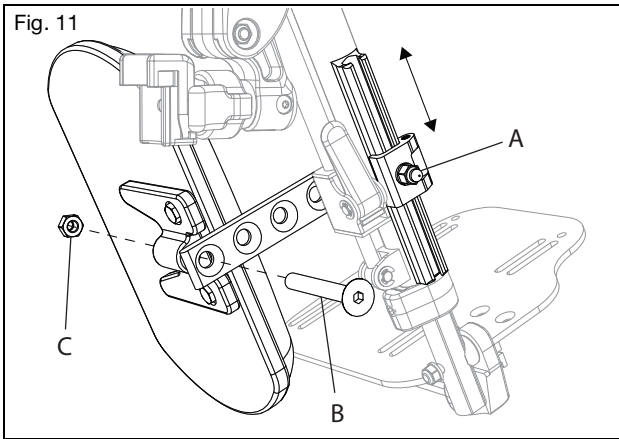

4. Adjusting the Length of Footrest
 - a. Loosen the set screw (Fig. 12:A) with a 4mm Allen wrench.
 - b. Slide the extension tube in or out to get to the desired length and secure by tightening the set screw.

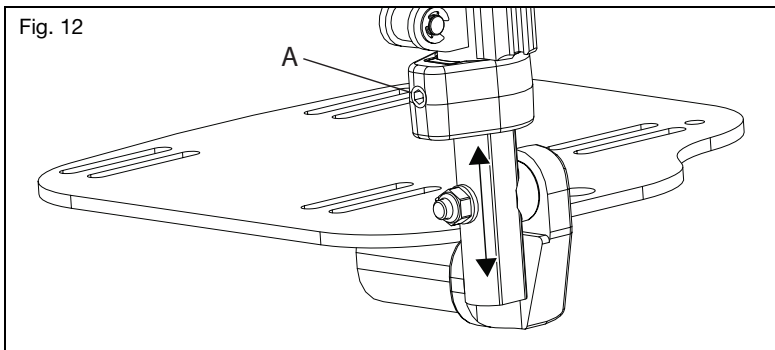

IV. WHEELCHAIR USE & CONFIGURATION

N. Pro Elevating Leg Rest (Continued)

5. Raising/Lowering the Pro Elevating Leg Rest

Remove the Pro ELR from the chair or remove weight from the Pro ELR while lowering to avoid a sudden drop when the lever lock is pushed. The calf pad can also swing outward to clear the front of the chair during certain movements if necessary.

- To raise the Pro ELR, lift the leg rest tube (Fig. 13:A) to desired angle of elevation.
- To lower the Pro ELR, press and hold the lever lock (Fig. 13:B) while pushing the leg rest tube (Fig. 13:A) down.
- Retighten the nut.

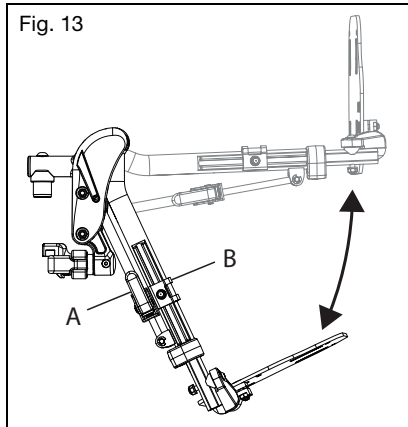

6. Removing the Pro Elevating Leg Rest

- To remove the leg rest, push or pull the release latch.
- Lift the leg rest straight upward to remove. You may also swing the leg rest inward or outward before lifting it off.

O. Adjustable Height Backrest

How to Adjust the Height (Fig. 14)

- Remove the two bolts from each rear side frame.
- After selecting the desired height, replace the bolt through the frame and backrest tube.

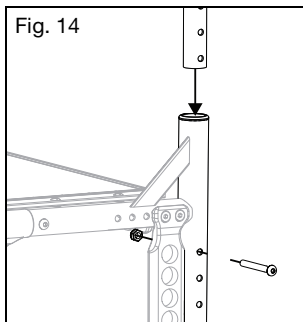

IV. WHEELCHAIR USE & CONFIGURATION

P. Half Folding Backrest

WARNING

WARNING: Avoid placing or hanging objects from the backrest canes. Placing objects on the backrest canes could result in an accidental release of the fold down lever on the half folding backrests. Releasing the fold down lever could cause a fall resulting in serious injury or death.

 **Do not use the chair if the back cane is not in operating position. Using the chair with the back cane out of position could cause a fall resulting in serious injury or death.**

Using the Half Folding Backrest (Fig. 15)

1. Press the release lever in towards the back cane while folding the back cane down.
2. Lift the back cane until it "clicks", or locks, to return it to the operating position.
3. See the Adjustable Height Backrest section for the steps on how to adjust the height of the Half Folding Backrest.

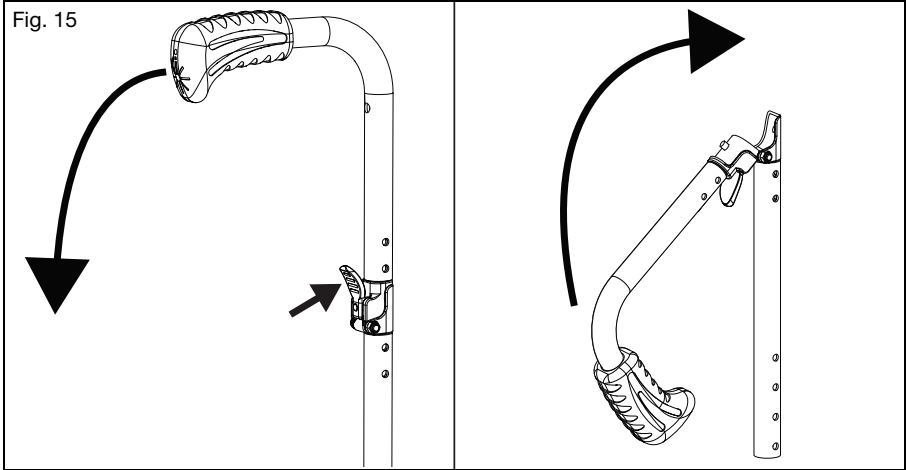

IV. WHEELCHAIR USE & CONFIGURATION

Q. Rear Wheels



WARNING: Before operating chair, assure the push button is completely extended and locking balls on the inside are fully engaged. Failure to do so may result in the wheel falling off, which could cause a fall or tip-over resulting in serious injury or death to you or others.

How to Use Your Rear Wheels

1. Installing the Wheels
 - a. Push in the quick release button (Fig. 16:B) on the axle (Fig. 16:C) to allow the locking balls to retract. Make note of the difference between the extended and depressed position of the axle release button and its effect on the locking balls on the other end of the axle.
 - b. Insert the axle into the bearing housing on the wheel if it's separate.
 - c. Push on the quick release button again and slide the axle into the axle sleeve (Fig. 16:A).
 - d. Release the button to lock the axle in sleeve. If the release button does not fully extend and the locking balls do not move into the locked position after releasing the button, the axle length needs to be adjusted.
 - e. If the wheel does not fit, try installing it on the opposite side.

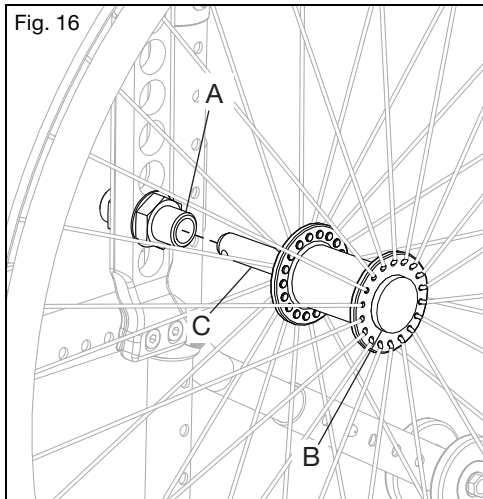

2. Removing the Wheels
 - a. Hold the wheel close to the hub and push the button in on the outside end of the axle.
 - b. While still holding the button, pull the wheel and the axle out of the axle sleeve.

IV. WHEELCHAIR USE & CONFIGURATION

R. Wheel Locks

WARNING

WARNING: Underinflated or worn tires may cause your wheel locks to not function properly. Failure of the wheel locks to hold your chair could cause a loss of control or fall resulting in serious injury or death.

How to Adjust Your Wheel Locks

NOTE: Always loosen and tighten wheel hardware by alternating between the two bolts while loosening/tightening a little at a time. This prevents overclamping on one set of hardware which leads to binding of the fasteners and increased difficulty in removal.

1. Use a 5mm Allen wrench to turn one of the screws in the clamp until it runs easily (less than one turn).
2. Repeat step 1 with the second screws so the clamp can be adjusted on the frame.
3. Adjust the clamp along the frame so the wheel lock properly compresses the tire and prevents any wheel movement. See Fig. 17.
4. Retighten the screws.
5. Always test new wheel lock positioning on a flat level surface. Once wheel locks are engaged, the wheels should not slip or move. If the wheel locks are not fitted properly readjust wheel lock again. See Fig. 18.

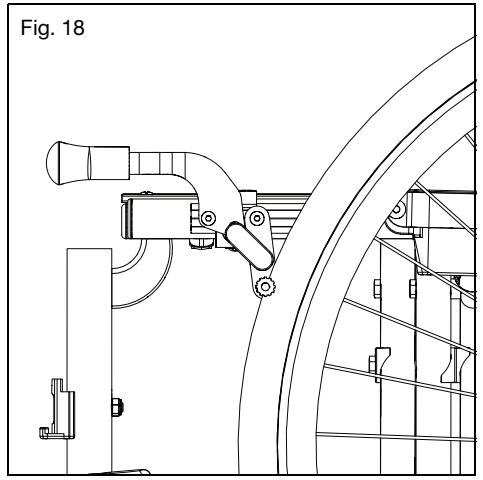
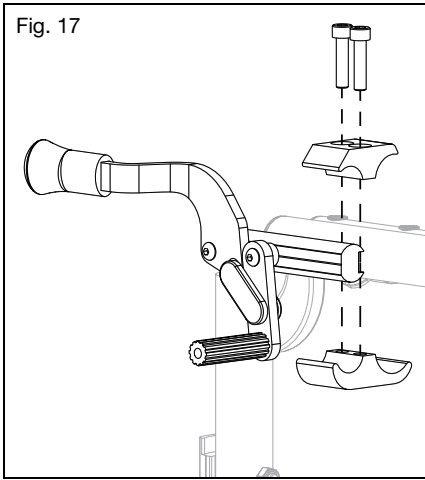

IV. WHEELCHAIR USE & CONFIGURATION

S. Anti-Tips

⚠️ WARNING ⚠️

WARNING: Always keep anti-tips in the down position when they are not at risk of interference. Have a clinical or technical professional confirm your anti-tips are installed in the correct position. They can do so by tipping the occupied wheelchair back on to the anti-tips to test that they properly limit the rearward rotation of your wheelchair. If the anti-tips allow your wheelchair to tip to a point where your center of gravity (COG) is vertically aligned with the point where the wheel contacts the ground, the wheelchair is unstable and could result in the wheelchair tipping over. Tipping over could result in damage to your wheelchair, serious injury or death.

⚠️ New and experienced wheelchair users switching to a new wheelchair or adjusting the configuration of a current wheelchair should always use anti-tips. If the user has a change in physical capabilities, they should use anti-tips as well. Any change in the user's physical capabilities or wheelchair increases the risk of tipping over backwards. Tipping over backwards could result in damage to your wheelchair, serious injury or death. You should always use anti-tips until you have adapted to the new or adjusted wheelchair.

⚠️ Remove or turn the anti-tips up when ascending or descending curbs, obstacles and steps. If the anti-tips are left in the down position when ascending or descending curbs, obstacles and steps, they can become bent or broken. If the anti-tips are bent or broken, they will no longer prevent the wheelchair from tipping over backwards. Tipping over backwards could result in damage to your wheelchair, serious injury or death.

⚠️ Using your wheelchair on soft surfaces (including but not limited to sand, loose soil, grass and gravel), uneven grades and ramps can cause anti-tips to lose effectiveness resulting in the wheelchair tipping over backwards. Tipping over backwards could result in damage to your wheelchair, serious injury or death.

⚠️ Ki mobility recommends using two anti-tips on your wheelchair. Use of a single anti-tip increases the risk of tipping over backwards. Tipping over backwards could result in damage to your wheelchair, serious injury or death.

Ki Mobility recommends using anti-tips with your wheelchair. Anti-tips help prevent your wheelchair from tipping over backwards. When adjusted properly, anti-tips provide a significant increase in rearward stability. Use of anti-tips does not guarantee your wheelchair will not tip over. Always remember to reinstall or turn the anti-tips to the down position after they were removed or turned to the up position.

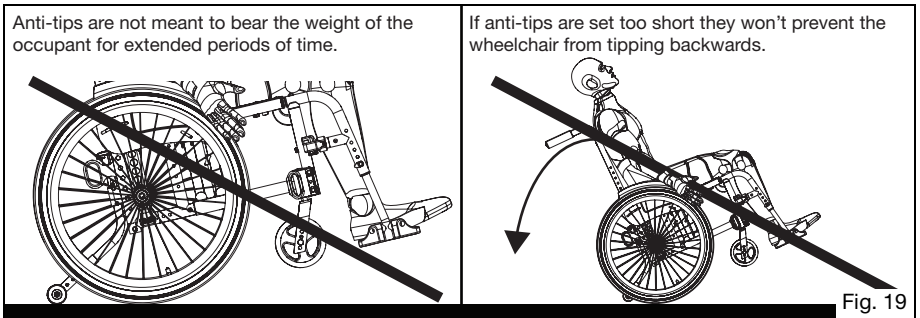

Fig. 19

IV. WHEELCHAIR USE & CONFIGURATION

S. Anti-Tips (Continued)

How to Install the Standard Anti-Tips (Fig. 20)

1. Press the rear anti-tip release pin on the anti-tip tube so both the release pins are drawn inside.
2. Insert the anti-tip tube into the receiver mounted on the camber tube.
3. Turn the anti-tip tube down until the release pin is positioned through the receiver mounting hole.
4. Insert the second anti-tip tube the same way.

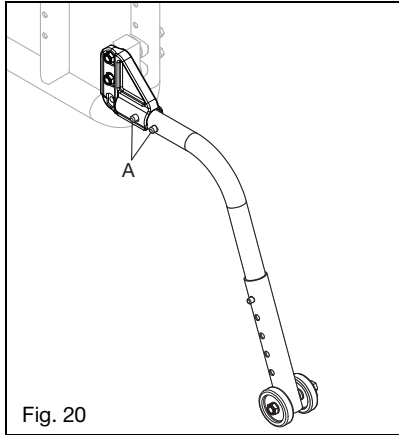

How to Adjust the Wheel Extension Height (Fig. 21)

1. Press the anti-tip wheel release pin so the release pin is drawn inside.
2. Raise or lower the anti-tip to any of the predrilled holes.
3. Release the pin.
4. Adjust the second anti-tip tube wheel the same way. Both of the wheels should be at exactly the same height.

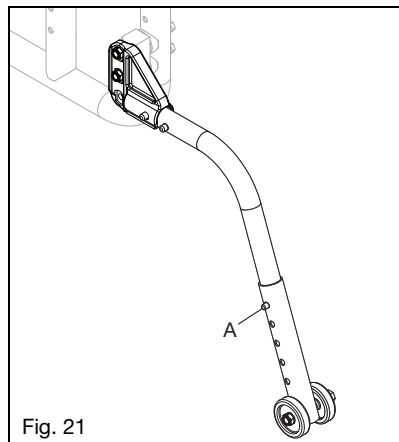

IV. WHEELCHAIR USE & CONFIGURATION

S. Anti-Tips (Continued)

How to Turn the Anti-Tip Tubes Up (Fig. 22)

1. Press the rear anti-tip tube release pin.
2. Hold the pin in and turn the anti-tip tube up.
3. Release the pin.
4. Repeat with the second anti-tip tube.
5. Return the anti-tip tubes to the down position after completing the maneuver.

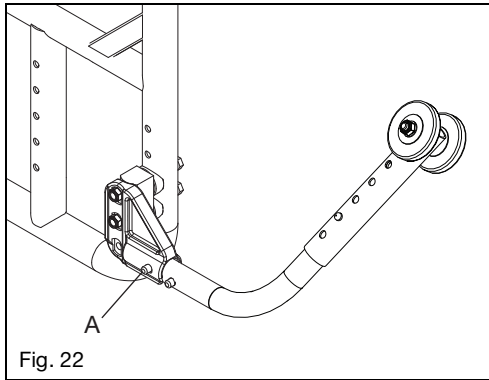

How to Adjust the Length of the Swing-In Anti-Tips (Fig. 23)

1. Press the anti-tip wheel release pin so the release pin is drawn inside.
2. Raise or lower the anti-tip to any of the predrilled holes.
3. Release the pin.
4. Adjust the second anti-tip tube wheel the same way. Both wheels should be the same height.

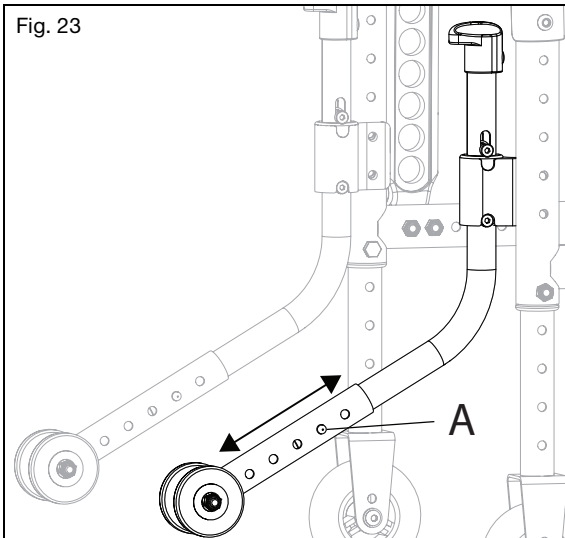

IV. WHEELCHAIR USE & CONFIGURATION

S. Anti-Tips (Continued)

How to Adjust the Position of the Swing-In Anti-Tip Receivers (Fig. 24)

1. Remove the bolts and nuts that connect the anti-tip tube receiver to the side frame of the chair.
2. The holes are in 1" (2,54 cm) increments so it can be moved farther up or lower on the frame. Place the bracket at the desired height.
3. Reinsert the bolts and tighten (If the bolts also connected the armrest and the axle plate you may need to contact your supplier for additional hardware because different bolt lengths may be required).
4. Adjust the second anti-tip receiver the same way. Both anti-tips should be in the same position.

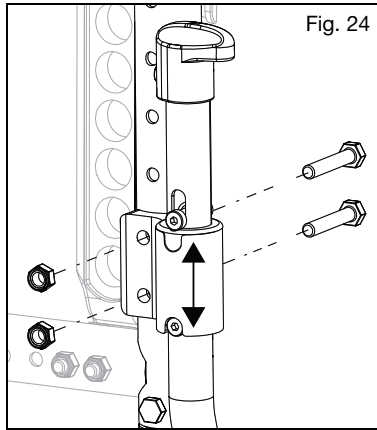

How to Rotate the Swing-In Anti-Tips (Fig. 25)

1. Push down on the anti-tip knob (Fig. 25:A).
2. Swing the anti-tip towards the inside of the chair.
3. Adjust the second anti-tip tube the same way. Both anti-tips should be in the same position.

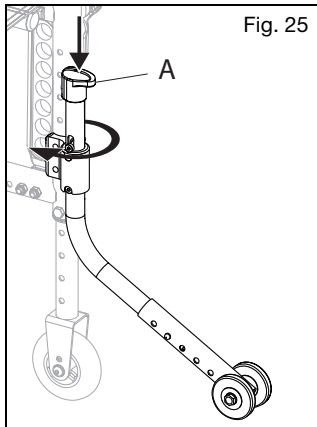

IV. WHEELCHAIR USE & CONFIGURATION

T. Upholstery Fabric

WARNING

WARNING: You must immediately replace seat and back upholstery that has worn through and shows signs of failing. If you fail to do so, the seat or back may fail which could cause a fall resulting in serious injury or death.

The seat sling material will weaken over time. The repeated action of transferring to your wheelchair will weaken your sling material quicker. Inspect your upholstery for fraying, thin spots or stretching of fabrics especially at edges and seams. This should be done monthly. Also, be aware that laundering or excess moisture will reduce flame retardation of the fabric. See the Maintenance and Care section for proper cleaning and maintenance notes. Contact your authorized supplier if you have concerns about your seat or back, or feel it needs to be replaced.

U. Seat Upholstery

WARNING

WARNING: You must immediately replace seat and back upholstery that has worn through and shows signs of failing. If you fail to do so, the seat or back may fail which could cause a fall resulting in serious injury or death.

How to Adjust Seat Upholstery Tension

NOTE: The seat upholstery includes a folding strap to assist in folding the chair. The folding strap is not intended as a carrying strap.

1. Reach under the seat upholstery to find the tension adjustable hook and loop flap. This should be located on the bottom, right side of seat upholstery.
2. Loosen the Phillips head screws (Fig. 26) on the same side of seat upholstery as the tension adjustable flap.
3. Separate the hook from loop on the tension adjustable flap by pulling apart.
4. To tighten the seat upholstery, pull the tension adjustable flap towards the opposite side of the chair. To loosen the seat upholstery, apply pressure from the top of the seat upholstery towards the ground.
5. When the seat upholstery has reached the desired level of tension, press the hook and loop back together.
6. Retighten the Phillips head screws (Fig. 26).

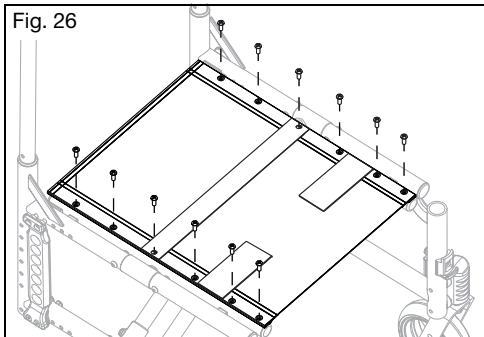

IV. WHEELCHAIR USE & CONFIGURATION

U. Seat Upholstery (Continued)

How to Replace Seat Upholstery

1. Remove the 5mm Phillips head screws (Fig. 26) from the seat rails on each side of the frame and set aside.
2. Remove the seat upholstery from the seat rails.
3. Slide the new seat upholstery onto the seat rails.
4. Line up the holes in the seat rails with the threaded inserts in the frame.
5. Replace 5mm Phillips head screws (Fig. 26) by partially threading into place. Once all screws have been started, go back and tighten to secure.

V. Oxygen Tank Holder



WARNING: Remove and secure any items temporarily attached to the chair while in a motor vehicle. Leaving items attached to the oxygen tank holder and not securing them properly and separately in a motor vehicle could result in these items becoming dangerous projectiles in the event of an accident.



Oxygen tanks can be dangerous if not used properly. Oxygen tanks contain a highly pressurized gas that vigorously accelerates combustion. Ensure you have been provided proper instructions for using an oxygen tank by the supplier of your tank. You must heed all warnings and follow all of the instructions for use that have been provided by the supplier of your oxygen tank. Failure to follow all of the instructions for use, and heed all warnings, for oxygen tanks can result in serious injury or death.

How to Use the Oxygen Tank Holder

1. Instructions for Use:

This oxygen tank holder has been designed to secure D cylinders to your wheelchair. Ensure that the bottle is well seated in the bottom of the holder and the clamp is tightened to the point that the cylinder cannot be pulled out.

W. Surface Temperature



WARNING: Handling of wheelchair surfaces with elevated temperatures can result in a potentially hazardous situation which, if not avoided, could result in injury.

Be aware that prolonged exposure to direct sunlight or other sources of radiant heat may increase the temperature of surfaces on your wheelchair above recommended limits estimated by standards.

IV. WHEELCHAIR USE & CONFIGURATION

X. Step Tube

WARNING

WARNING: Ensure occupant is seated securely in the chair before stepping onto the step tube. An occupant not seated securely while the step tube is used could fall resulting in serious injury or death.

How to Install the Step Tube (Fig. 27)

1. Slide the step tube into the rear frame and secure with bolt and nut.

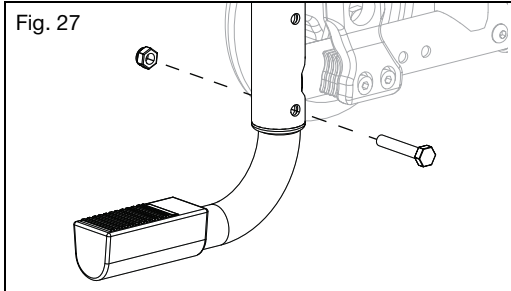

Y. Transit Wheels

How to Install the Transit Wheels (Fig. 28)

1. Install the transit wheel into the rear frame and secure with bolt and nut.

How to Adjust the Transit Wheel Height (Fig. 28)

1. Remove the bolt and nut from the transit wheel.
2. Slide the transit wheel up or down to the correct height.
3. Secure the desired height by reinstalling the bolt and nut.

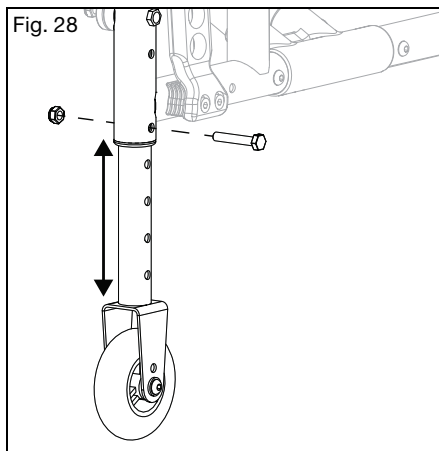

V. MAINTENANCE AND CARE

A. Maintenance Table

Regular and routine maintenance will extend the life of your wheelchair while improving its performance. Wheelchair repairs, the replacement of parts and any maintenance check that you are not comfortable performing should be done by an authorized supplier. Only use Ki Mobility approved parts when replacing components.



CAUTION: Do not use petroleum-based solvents, degreasers or dewatering agents (including but not limited to automotive cleaners, alcohols or WD-40). Damage to components, bearings or finishes may occur.

Check	Weekly	Monthly	Annually
Check the tire inflation levels and inflate as needed. The correct inflation levels are found on the tire.	✓		
Check wheel lock engagement and disengagement. Tire pressure changes and tire wear will require the wheel locks to be adjusted. Wheel lock adjustment instructions can be found in the Wheel Locks section of this manual.	✓		
Check the axle sleeves to ensure the axle sleeve nuts are tight.	✓		
Check that quick release axles engage and disengage properly.	✓		
Check that caster wheels, anti-tip wheels and rear wheels spin freely. Cleaning or replacement parts may be needed if there are any issues.	✓		
Clean area around the caster housing and bearings. This is a common location for hair build up.	✓		
Clean your wheelchair. See the Cleaning section in this manual for instructions.	✓		
Check the rear tires, anti-tip wheels and the caster wheels for wear spots or damage. Replace immediately if needed.	✓		
Check handrims to ensure they are secure and not damaged.	✓		
Check that the hand grips do not rotate or pull off. Replace if needed.	✓		
Check armrest receivers for loose or missing fasteners and check they are secure, adjusted properly and maintain position.	✓		
Check that anti-tips are level and functional.	✓		
Inspect the frame(s) and anti-tips for deformities, defects, cracks, dimples or bends. These could be signs of fatigue in the wheelchair which could result in a failure. Discontinue use of the wheelchair immediately and contact an authorized supplier.		✓	
Check upholstery for signs of wear, fraying or holes. Replace upholstery immediately if needed.		✓	
Check arm pads, cushions and back rest for damage, rips or tears.		✓	
Check wheels for any loose, broke or bent spokes. Replace immediately if needed.		✓	
Check that all fasteners are tight. Unless otherwise noted, fasteners should be tightened to 40 in./lbs (4.51 N*m).		✓	
Verify the wheelchair rolls easily and straight.		✓	
Have the wheelchair checked and adjusted by a qualified technician at your authorized supplier.			✓

V. MAINTENANCE AND CARE

B. Cleaning



CAUTION: Washing upholstered components containing flame retardants, as indicated on the labeling of the upholstery, may reduce the flame retardants' efficacy over time. This may increase the risk of ignition when exposed to open flame or other ignition sources, which may increase the risk of injury.

Axles, Wheels, Tires and Moving Parts:

1. Clean around the axles and wheels weekly with a damp rag.
2. Hair and lint will lodge in and around the caster housing and rear wheel axles. Remove with a stiff brush or pick. Take care not to damage bearing seals.

Painted Surfaces

1. Hand wash using a cloth and mild detergent.
2. Dry using a clean cloth or allow wheelchair to air dry.
3. Nonabrasive wax may be used to help preserve painted surfaces.

Upholstery:

1. Hand wash using a cloth and mild detergent.
2. Allow upholstery to air dry. **DO NOT** machine dry.

Plastic Components

1. Hand wash using a cloth and mild detergent.
2. Do not use solvents or aggressive cleaners as they may damage plastic components.

C. Storage

1. When not in use, keep your chair in a clean, dry area. Failure to do so may result in your chair rusting and/or corroding.
2. If your chair has been in storage for more than two months, it should be serviced and inspected by an authorized supplier before use.

V. MAINTENANCE AND CARE

D. Disposal

Specific waste disposal or recycling regulations may be in force locally and these should be taken into consideration when disposal arrangements are made. This may include the cleaning or de-contamination of the wheelchair before disposal.

If recycling of materials is a requirement, please refer to the following list of general materials used in the components of the wheelchair:

- Aluminum - Frame, caster fork, caster mount, bearing housing, camber tube assembly, backrest mount plates, backrest frame, backrest release bar, push handles, footrest tubes, footplate, seat rails, handrim and wheel rim.
- Steel - Fasteners, QR axles, caster stems, backrest release latch, wheel spokes, bearings and axle sleeve.
- Plastic - Rear wheels, caster tires, push handle grips, armrest pads and tube plugs.
- Upholstery - Woven polyester fabric and polyurethane foam.

If recycling of materials is desired or a requirement, such as per Directive 2012/19/EU, WEEE (Waste Electrical and Electronic Equipment) in Europe, both REAC and Mascot are compliant to WEEE and provide guidance on recycling and disposal. Proper dismantling is necessary to achieve a high proportion of reuse or recycle. Care to use proper tools and protective measures in handling are required to avoid contact with sharp edges.

Plastics marked with recycling symbols and thermoplastic parts can be recycled. Aluminum, copper and steel parts, including fasteners, may be recycled. Cables, batteries and PCB are to be disposed separately per local requirements.

Return your chair and accessories to your authorized supplier for proper disposal if you are not comfortable or able to dispose of your wheelchair properly.

VI. TROUBLESHOOTING

A. Symptoms and Solutions

For optimum performance, your wheelchair needs to be adjusted occasionally. The following is a list of potential symptoms you may encounter over the life of your wheelchair and the suggested solutions for each symptom. For best results when troubleshooting, try one solution at a time before proceeding to a second solution. If symptoms are not relieved or you are not confident in performing the solution, it is recommended to take the wheelchair to an authorized service center for repair.

Solutions:

A - Self Correct if capable or contact Authorized Distributor

B - Contact Authorized Supplier or Distributor

		Symptoms							
		Chair pulls to one side	Looseness in chair	Difficulty turning	Caster Float	Caster Flutter	Squeaking, clicking or rattling	Wobbling	
Solutions	B	Add spacer washer into caster housing (Ref. instructions).	X						
	A	Ensure all tire pressures are correct and equal.	X		X	X			X
	A	Check to make sure all fasteners are tightened appropriately, tighten if necessary.	X	X	X	X	X	X	X
	B	Tighten spokes (if present).		X				X	X
	A	Check to make sure casters are contacting the ground and float is not present.	X		X		X		
	B	Optimize CG setting.			X		X		
	A	Check caster housing squareness	X		X	X	X		
	A	Check for interference at rear wheel and front casters.	X		X			X	X
	A	Lubricate w/Teflon based lubricant between frame connections and mating parts in suspect areas.						X	
	A	Remove caster/bearing debris.	X		X		X		X

VII. WARRANTY

Ki Mobility warrants the frame, cross braces, hangers and quick-release axles of your Catalyst wheelchair against defects in materials and workmanship for the life of the original purchaser. All other parts and components of this wheelchair are warranted against defects in materials and workmanship for one year from the date of first consumer purchase.

The expected life of the frame is five years.

Limitations to the Warranty

1. We do not warrant:
 - a. Wear items: Upholstery, tires, armrest pads, tubes, armrests and push-handle grips.
 - b. Damage resulting from neglect, misuse or from improper installation or repair.
 - c. Damage from exceeding weight limit.
2. This warranty is VOID if the original chair serial number tag is removed or altered.
3. This warranty is VOID if the original chair has been modified from its original condition and it is determined the modification resulted in failure.
4. This warranty applies in the USA only. Check with your supplier to find out if international warranties apply.

Ki Mobility's Responsibility

Ki Mobility's only liability is to replace or repair, at our discretion, the covered parts. There are no other remedies, expressed or implied.

Your Responsibility

- a. Notify Ki Mobility, via an authorized supplier, prior to the end of the warranty period and get a return authorization (RA) for the return or repair of the covered parts.
- b. Have the supplier send the authorized return, freight pre-paid, to:
Ki Mobility
5201 Woodward Drive
Stevens Point, WI 54481
- c. Pay any charges for labor to repair or install parts.



 Ki Mobility
5201 Woodward Drive
Stevens Point, Wisconsin 54481
715-254-0991



www.kimobility.com



DCN0251.1