

Dynamis TSD



Instructions for use

Impressum

SORG Rollstuhltechnik GmbH + Co. KG
Benzstraße 3-5
68794 Oberhausen-Rheinhausen / Germany

Fon +49 7254-9279-0
Fax +49 7254-9279-10
Mail expert@sorgrollstuhltechnik.de
Web www.sorgrollstuhltechnik.de

Revision status

2021-05-26

Technical status

We reserve the right to make technical changes and misprints. The images can differ from the actual individual equipment components. The handling is to be carried out accordingly.

Gender notice

For editorial reasons for better readability, only the masculine form is used. Corresponding terms apply in the sense of equal treatment to all genders and do not represent any valuation.

Copyright

All content, especially texts, photographs and graphics, are protected by copyright. All rights, including reproduction, publication, editing and translation, are reserved. © by SORG Rollstuhltechnik GmbH+Co. KG Benzstraße 3-5, 68794 Oberhausen-Rheinhausen / Germany.

 You can find our general terms and conditions on our order forms and at www.sorgrollstuhltechnik.de/impressum.

1 Wheelchair overview	4	4 Repairs / maintenance / re-use	30
2 General informations	5	4.1 Repairs	30
2.1 Introductory	5	4.2 Spare parts	30
2.2 General information, instructions for use	5	4.3 Cleaning	30
2.2.1 Explanation of symbols	6	4.4 Disinfection	30
2.2.2 purpose	7	4.5 Storage	30
2.2.3 Indication	7	4.6 Lifespan	31
2.2.4 Contraindications	7	4.7 Re-use	31
2.3 General safety instructions	8	4.8 Disposal	31
2.3.1 Loading and transport without occupants	10	4.9 Maintenance / inspection	31
2.3.2 Transporting the wheelchair with occupants in the vehicle	10	5 Technical data	33
2.3.3 Other important information	11	5.1 Data and measurements	33
3 Handling		5.2 Meaning of the labels	34
3.1 Handling of wheels	13	5.3 Declaration of Conformity	34
3.1.1 General information on wheels	13	6 Proof of annual inspection	35
3.1.2 Tire pressure	13		
3.1.3 Quick release wheels	13		
3.2 Handling of caster wheels	14		
3.2.1 General information on caster wheels	14		
3.2.2 Caster wheel track fixation	14		
3.3 Handling the seat and back	15		
3.3.1 General information on the back	15		
3.3.2 Dynamic back	15		
3.3.3 Setting the rebound speed	15		
3.3.4 Seat tilt	16		
3.4 Handling pushing aids	17		
3.4.1 General information on pushing aids	17		
3.4.2 Push handle	17		
3.5 Using the leg support	19		
3.5.1 General information on leg supports	19		
3.5.2 Dynamic legrest	19		
3.5.3 Footplate	20		
3.6 Handling of the brake system	21		
3.6.1 General information on the brake	21		
3.6.2 Drum brake	21		
3.6.3 Locking brake	22		
3.7 Handling the anti-tipper	23		
3.7.1 General information on the anti-tipper	23		
3.8 Handling the headrest	24		
3.8.1 General information on headrest	24		
3.9 Handling of the abduction wedge	25		
3.9.1 General information on the abduction wedge	25		
3.10 Handling the therapy table	26		
3.10.1 General information on the therapy table	26		
3.11 Armrest handling	27		
3.11.1 General information on armrests	27		
3.12 Handling of the lateral support	28		
3.12.1 General information on lateral support	28		
3.13 Handling of the outdoor-front-end	29		
3.13.1 General information on the outdoor-front-end	29		

1 Wheelchair overview

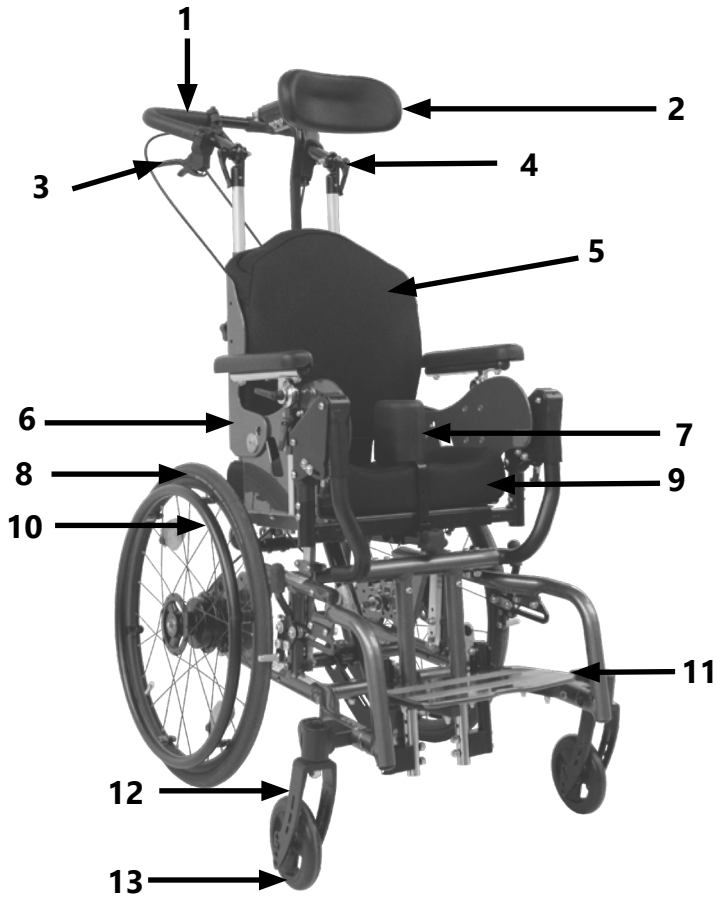

- 1 Push handle
- 2 Headrest
- 3 Drum brake control levers
- 4 Eccentric clamps for angle adjustment
- 5 Molded back cushion
- 6 Ergo-seat
- 7 Abduction wedge
- 8 Wheels
- 9 Molded seat cushion
- 10 Handrim
- 11 Footplate
- 12 Caster fork
- 13 Caster wheel

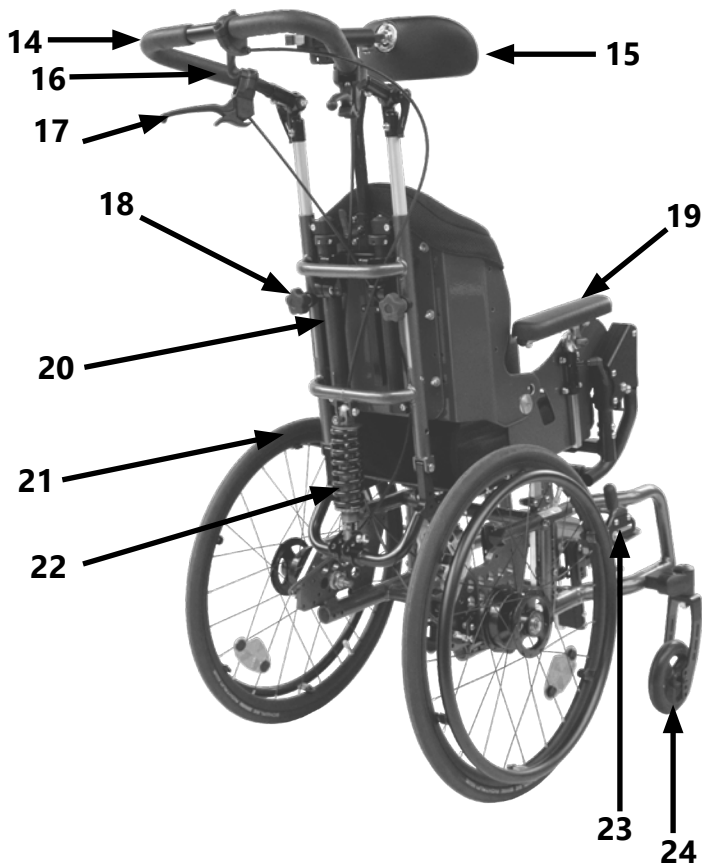

- 14 Push handle
- 15 Headrest
- 16 Release lever for seat tilt
- 17 Control lever for drum brake
- 18 Star grip for angle adjustment of the handlebar
- 19 Armrest
- 20 Back guide
- 21 Wheel
- 22 Spring damping
- 23 Knee lever brake
- 24 Caster wheel

2.1 Introductory

Welcome to the SORG family - thank you very much for the trust you have placed in us and for choosing our product.

This wheelchair has been individually made to measure for your special needs.



In order to be able to use the wheelchair in everyday life, you will receive the following instructions for use and adjustment, which you can use without tools. Please follow these instructions and handle your wheelchair carefully so that you can enjoy it for as long as possible.

If you have any questions about this or any other product, please do not hesitate to contact us.

We hope you enjoy your SORG product.

Your SORG-Team

2.2 General information instructions for use

These instructions for use contain safety and handling instructions that are required for the right use of the product.

All settings, adjustments, repairs and the annual inspection that go beyond these operating instructions must be carried out by a qualified specialist retailer.

Our service booklet can be accessed for further information at www.sorgrollstuhltechnik.de.

The user and specialist retailer must have read and understood these instructions before commissioning. These instructions for use contain all equipment variants of the product. Let your specialist advisor instruct you on level ground and with the support of an attendant in the safe handling of the wheelchair and your individual equipment versions.

 Visually impaired people can find these instructions for use as PDF and audio files on our website www.sorgrollstuhltechnik.de.

If you have any questions or comments, please contact your specialist retailer or our team (+49 7254 9279-0).

Keep these instructions for use in a safe place. All annual inspections carried out must be documented by the specialist retailer.

2.2.1 Explanation of symbols



DANGER! Warnings for personal safety issues, of utmost importance



CORRECT safety-relevant setting / handling



INCORRECT setting / handling



FORBIDDEN



Reference to additional / further reading.



Important detail / element



Correct or proper setting / use



Inadmissible or incorrect setting / use

(A); (B)

Reference from text to detail

Handling



Push / pull / insert / move / remove



Push in a certain direction



Set or adjust angle



Open / close



Turn clockwise



Rotate counter clockwise



Steps to be performed at the same time



Steps to be performed in sequence



Steps to be performed on both sides

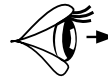

Point of view



View from above

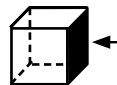

Side view



View from below

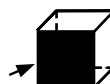

Front view



Rear view



Attach part



Remove part

2.2.2 Intended use

The Dynamis TSD is a wheelchair with a tilting function for indoor and outdoor use.

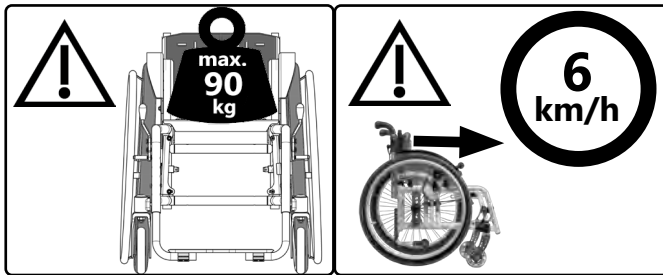

The wheelchair is only used to transport the person for whom it has been adapted by a qualified specialist retailer.

In the case of children or persons with impaired action skills, the parents or authorized caregivers must ensure that the information in the instructions for use is followed. The safe use of the aid is only possible on level, firm and dry ground with the anti-tipper activated with the help of an attendant.

Dynamis TSD is an aid for the mobility of physically and mentally disabled people. Its dynamic functions enable the user to carry out guided motor movements..

Any use going beyond this, harbors a variety of dangers that can only be assumed at the user's own responsibility. This presupposes sufficient competence in hazard identification and avoidance and the safe handling of the aid by the user as necessary! Particular attention must be paid to the increased risk potential in wet conditions, ice, loose ground, slopes, obstacles, proximity to water, traffic, bottlenecks, etc.

Only use the wheelchair for its intended purpose. Any improper use harbors considerable dangers and leads to the expiry of product liability.

Due to the large variety of combinations for seat and wheel position, settings may be possible that are outside the safety and application area.

2.2.3 Indication

the use is suitable i. a. at

- Limited / lack of mobility
- Movement disorders or restrictions
- Hemiparesis
- Traumatic brain disorders or injuries
- Other neurological diseases
- Increased spasticity

2.2.4 Contraindication

- Inability to sit due to increased skin sensitivity (e.g. decubitus)

We do not take any responsibility for damage to persons or objects under the circumstances described above.

2 General informations

2.3 General safety information

Check before every journey:

- Frame, back unit, add-on parts and accessories for visible damage, bends, cracks or missing / loose screws,
- Wheels / thru axles on tight fit,
- sufficient tire pressure, tire profile,
- Functionality of the brakes,
- tight fit of the angle adjustment elements / eccentric clamps,
- Function of the back and the legrest,
- Functionality of the anti-tipper / seat and shoulder straps,
- whether all previously dismantled parts are reinserted and firmly locked.

There is a risk of injuries (e.g. crushing) on all rotating, rotatable or foldable parts, also during adjustment and repair work as well as during transportation.

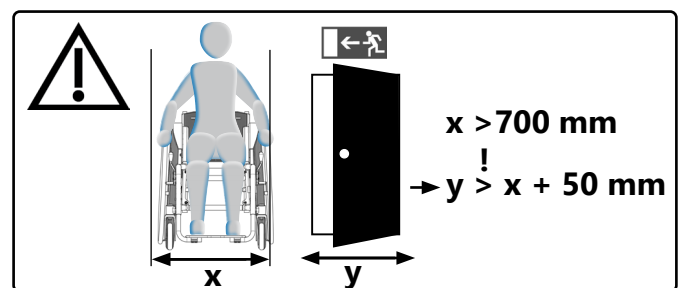
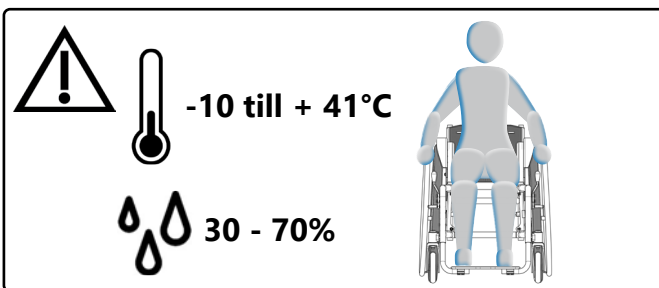

Risk of tipping over and rollover

Entry and exit may only be carried out with the brake and anti-tipper activated.



Do not use the footplate to get in and out. The wheelchair could tip forward.

When dismantling the parts / accessories listed below, the risks listed as examples may arise:

- Legrest: Trapping the legs during transport and wheelchair access
- Headrest: Missing headrest or loss during transport
- Armrest: Loss during transport
- Push handle: Loss or lack of pushing option during transport or wheelchair access.

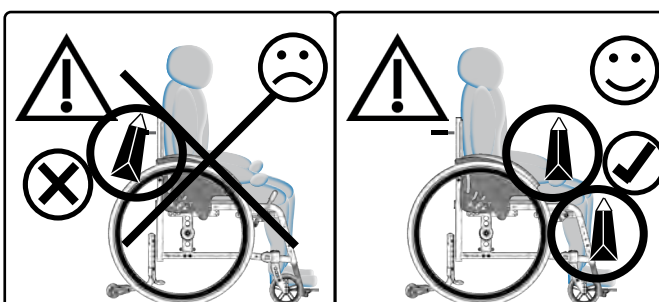

2 General informations

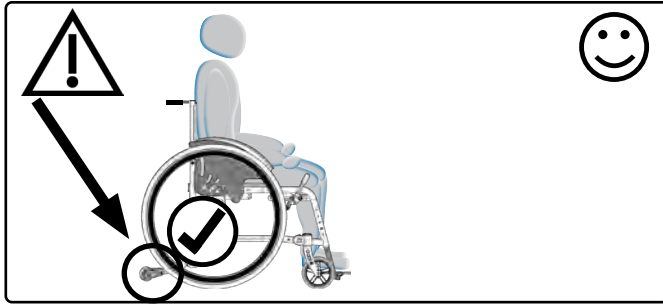

⚠ We generally recommend using the anti-tipper.

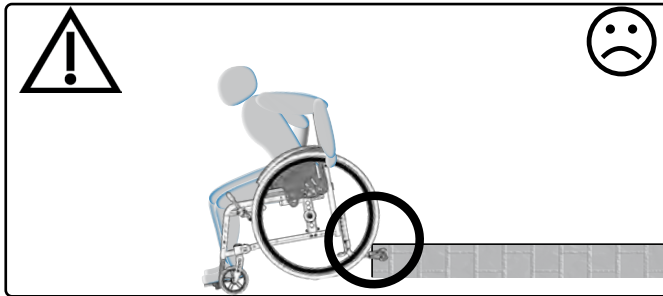

⚠ The anti-tipper must be deactivated when driving down on edges.

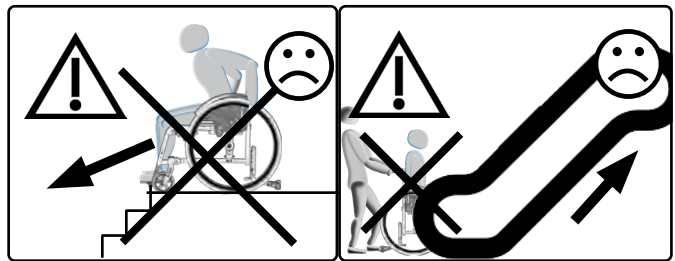
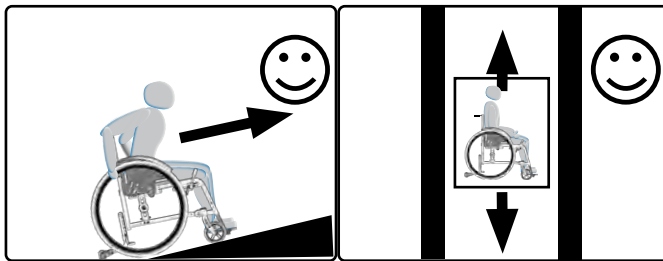

⚠ Conquer stairs only with the help of experienced helpers. To do this, the anti-tipper must be deactivated. Always carry the wheelchair **by the frame, never** by the seat shell, the pull-out push handles / bush bar, the legrest and / or the footplate!

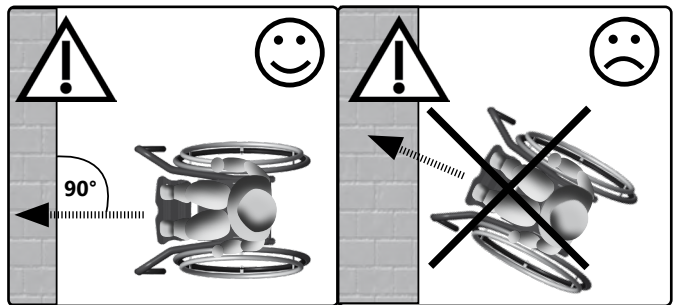
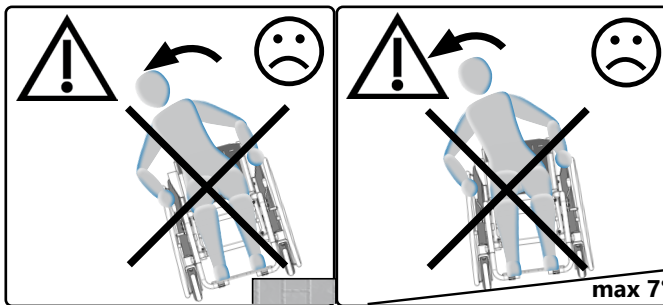

Inclines, slopes and obstacles

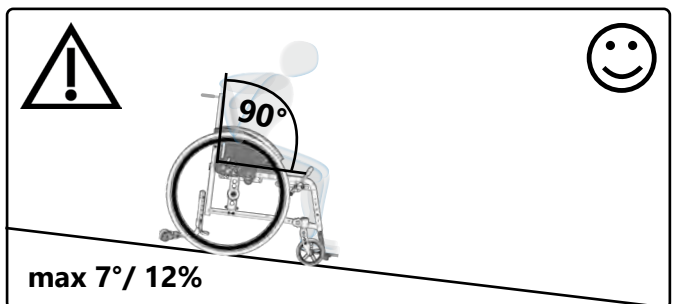
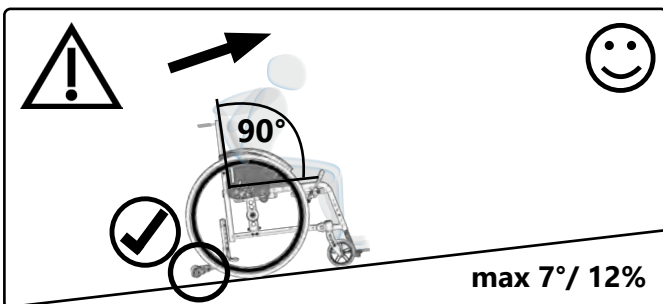

2 General informations

2.3.1 Loading and transport without occupants

Create the desired pack size and secure the wheelchair and all dismantled parts with adequate load securing. Basically, the wheelchair is suitable for transport (land / air). Find out about suitable load securing measures before transporting the wheelchair.

Support points:

- Frame tubes rear left / right
- Front frame tubes left /right
- But **NOT** by the footplates.

2.3.2 Transport of the wheelchair with occupants in the vehicle

 Due to their purpose, wheelchairs can never achieve the stable properties of a seat system that is permanently mounted in the vehicle. Whenever possible, we recommend using a fixed vehicle seat to transport a person in the vehicle.

 Only wheelchairs that have successfully passed a crash test according to ISO 7176-19 may be used as a seat in a motor vehicle. Successfully tested wheelchairs are marked with the symbol for the attachment point on the attached nameplate.



The Dynamis TSD has been successfully tested according to ISO 7176-19 and is therefore approved as a seat in a motor vehicle if you have the necessary restraint devices.



 Please check whether your wheelchair is custom-made and may therefore not be used as a seat in a motor vehicle.

 For more information, see the crash test brochure at: www.sorgrollstuhltechnik.de/downloadportal.

We can recommend the following manufacturers of restraint systems:

- SORG-transport brackets on the wheelchait
- AMF-BRUNS GmbH & Co.KG
- Q'Straint Europe

Attachment points / methods for transportation in motor vehicles

 When using the wheelchair as a seat in the motor vehicle, only use the places marked with the symbol for the attachment point. These are usually located in the back left and right **(1)** and the front left and right. **(2)**

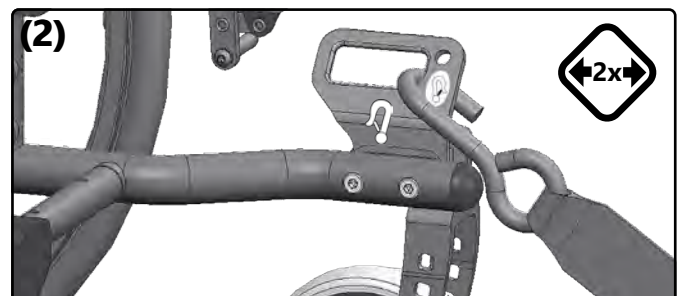
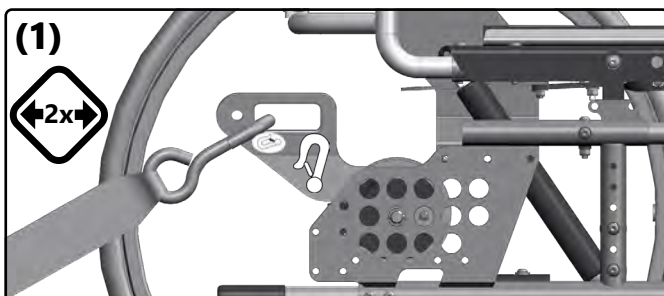

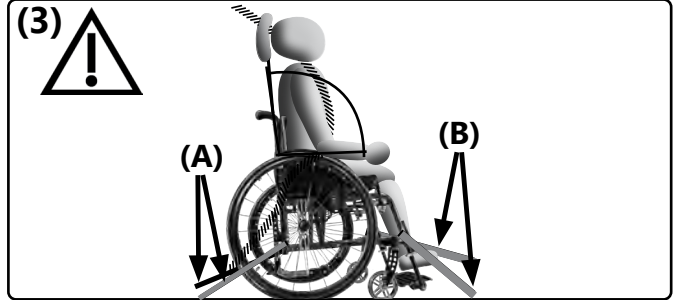

 The wheelchair must be attached using a vehicle-anchored 4-point wheelchair restraint system in accordance with ISO 10542. These can be snap hooks, S-shaped hooks or snap fasteners. The wheelchair restraint system must be securely attached and used in accordance with the manufacturer's instructions for use. **(3A+B)**



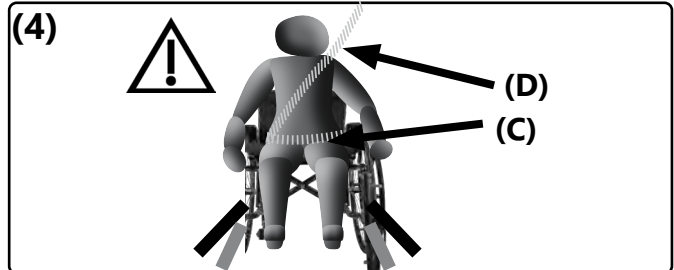

 Bring the seat into a horizontal position **(3)**. The back suspension and the leg support can be locked in the basic position. (**Chapter 3.3 Handling the back and seat, as well as Chapter 3.4. Legrests**)

 In order to reduce the risk of head and upper body injuries as much as possible, the sure must be secured with a fixed lap belt **(4C)** approved for transportation in accordance with ISO 10542 and a vehicle-anchored shoulder belt **(4D)**.





 The seat belts must not be twisted during use, nor guided over components and thus kept away from the body. They have to be put on tightly and firmly in place without impairing user comfort. The pelvic belt buckle must be between the pelvic bones (as centrally as possible). The buckle tongues on the pelvic belt for fastening the shoulder belt should be on the outside of the pelvis, if possible.

 All belts used for transport must be checked for damage at regular intervals.

 A headrest approved for transport must be used.

 According to ISO 7176-19, the wheelchair may only be used as a forward-facing seat in motor vehicles. No transport with side orientation!

 After a collision, contact your specialist retailer immediately to check the chassis, frame and brakes and have any damage repaired immediately.

 In addition, actuate the existing braking devices on the wheelchair to transport the wheelchair in the vehicle.

2.3.3 Other important information

 The standard-compliant resistance to ignition in textile materials has been tested and ensured. Nevertheless, there is a risk of ignition of the hardly inflammable textile components. Keep sources of ignition away from the wheelchair.

 The wheelchair must not be exposed to excessive moisture or come into contact with salt water.

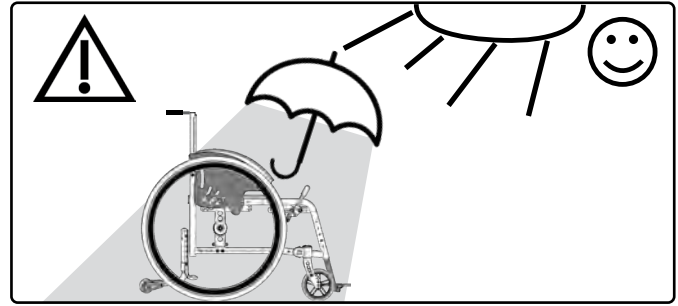
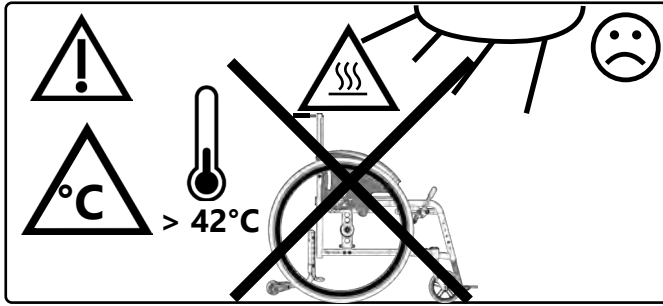

Pelvic safety devices (pelvic belts as a positioning aid) are optionally available for wheelchair configuration via the SORG order forms or by ordering using spare parts catalogs. Installation is carried out by your specialist retailer.

In individual cases it can happen that the product interacts with electromagnetic fields (e.g. theft protection of shops). This poses no danger to the user and / or the companion.

Due to the wide range of setting options, not all limit values can be complied with for all possible configurations according to the Regulation (EU) on the technical specifications for interoperability with regard to the accessibility of the Union's rail system for people with disabilities and people with reduced mobility.

In the event of incidents with the wheelchair, please contact your specialist retailer or us as the manufacturer. Product recalls etc. are published on our website www.sorgrollstuhltechnik.de. There you will also find the respective contact person.

Corrosion protection

The product is already designed for corrosion protection when the materials are selected (e.g. plastic, aluminum, stainless steel). All materials at risk of corrosion are surface treated and therefore protected.

The wheelchair must be dried thoroughly if it gets wet.

Lifespan

Use beyond the specified service life leads to an increase in the residual risks and should only be carried out after careful, qualified consideration by the operator. If the service life is reached, the user or a responsible person should contact the specialist retailer. There you can get information about the possibility of reconditioning the product.

Combination with products from other manufacturers

The wheelchair may only be combined with the additional electrical drives approved by the manufacturer. Restrictions or adjustments as well as the cultivation itself are the responsibility of the provider of the additional system or the commissioned specialist trade. Please ask the manufacturer of the additional drives for the requirements.

In the combination of a wheelchair and an additional electric drive, particular loads occur that can lead to damage to the wheelchair. Approach obstacles slowly and overcome them carefully so that little force is exerted on the caster wheel, drive wheel and the wheelchair as a whole.

3.1 Handling of wheels

3.1.1 General information on wheels

Braking the wheels on the hand rims creates frictional heat.

Hand rim covers can stretch in the heat and loosen from the hand rim.

3.1.2 Tire pressure

You will find the appropriate operating pressure on the tire - usually 3-10 bar. **(1)**

If you have a flat tire, please contact your specialist retailer.



3.1.3 quick release wheels

Remove:

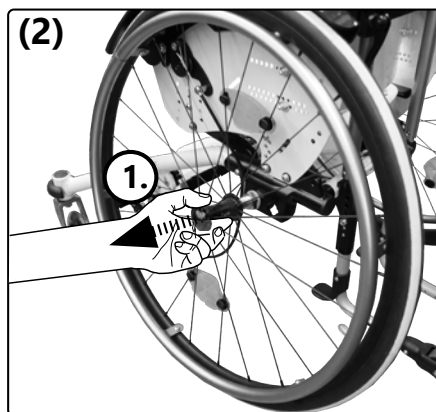
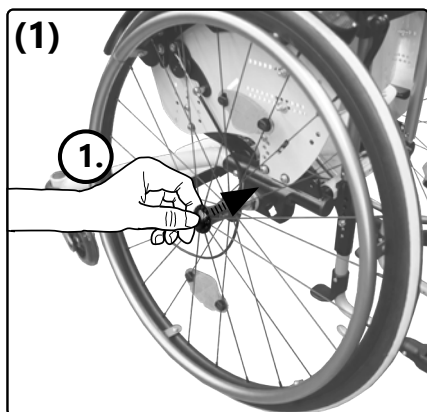

Install:

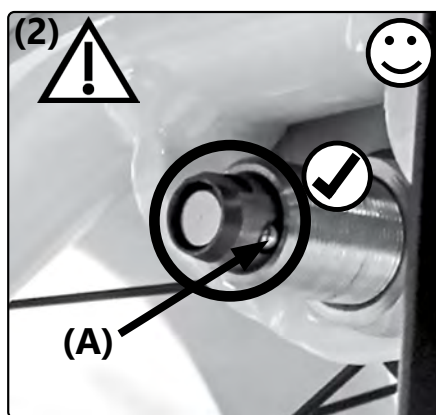
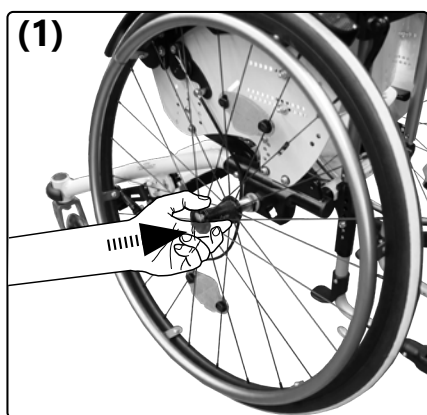

(2) After insertion, the locking ball **(A)** must protrude visibly. Ziehen Pull at least 1x after each insertion to test whether the quick-release axle is engaged. It should no longer be possible to pull the wheels outwards.

3.2 Handling of caster wheels

3.2.1 General information on caster wheels

Incorrectly adjusted caster wheels or driving too fast can lead to steering wheel flutter. At the first sign of a flutter, slow down immediately and have the caster wheels readjusted by a specialist retailer.

3.2.2 Caster wheel track fixation

Unlocking:

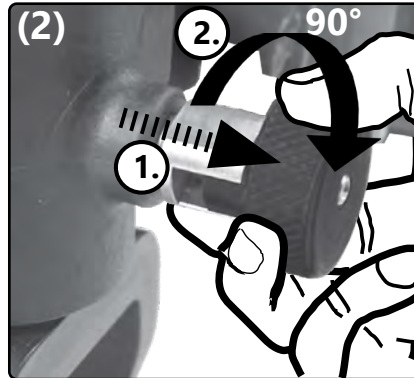
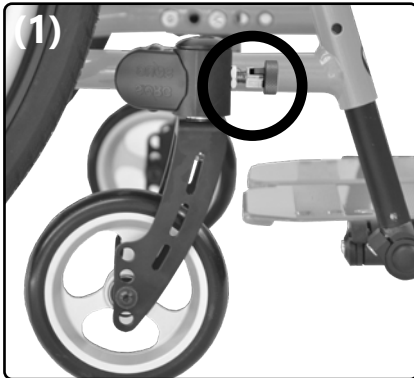

Locking:

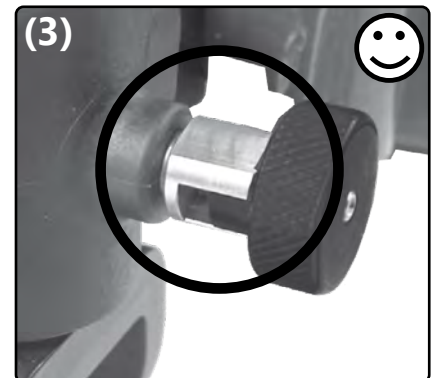
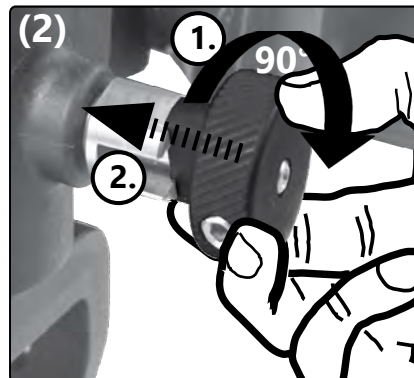
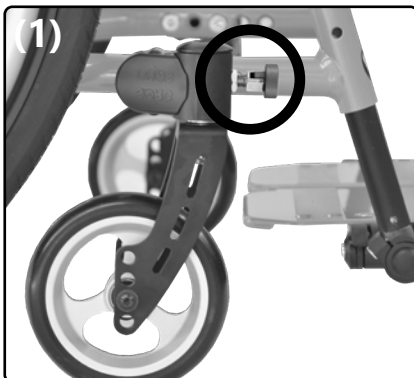

3.3 Handling the seat and back

3.3.1 General information on the back

Check all components for correct function after every change to the back.

In the case of seat tilts from a setting of $> 90^\circ$, it is essential to activate the anti-tipper. The head must be supported during tilting (e.g. by a headrest).

Activate the seat tilt only when the vehicle is stationary with the brakes activated.

3.3.2 Dynamic back

Locking (unlocking: proceed in reverse order):

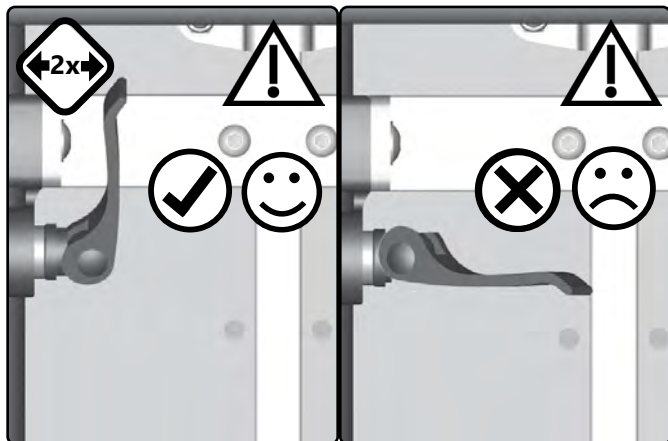
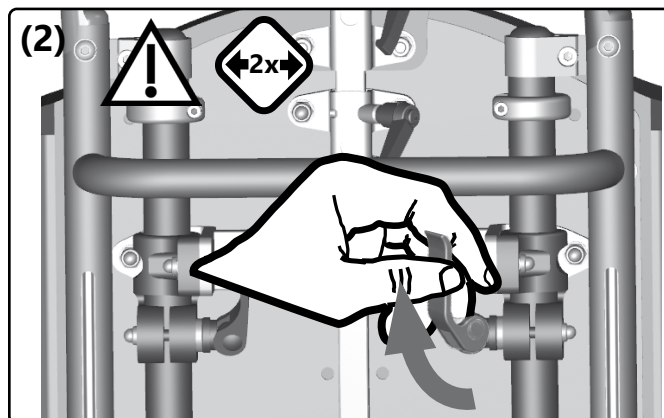
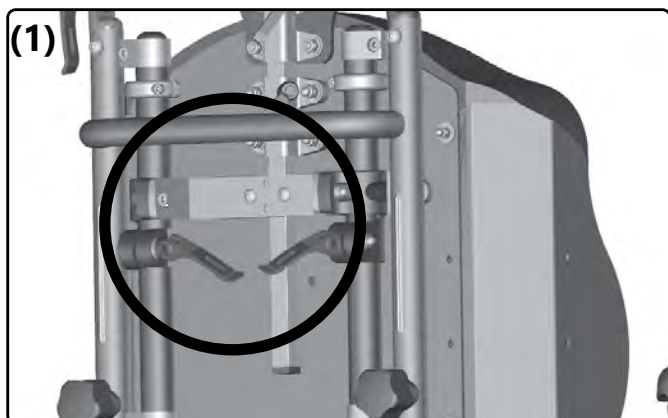

Please have the spring damping adjusted by a specialist retailer (see service booklet)



3.3.3 Setting the rebound speed

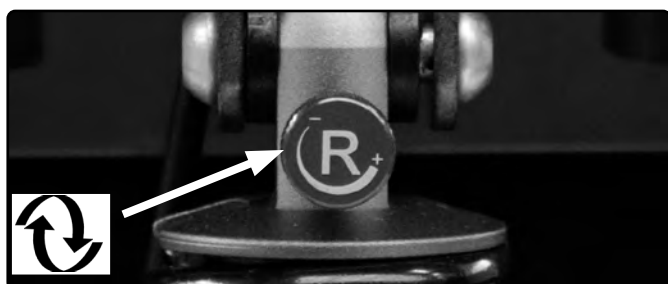

3.3 Handling the seat and back

3.3.4 Seat tilt

Tilting simple gas pressure spring:



Tilting double gas pressure spring:

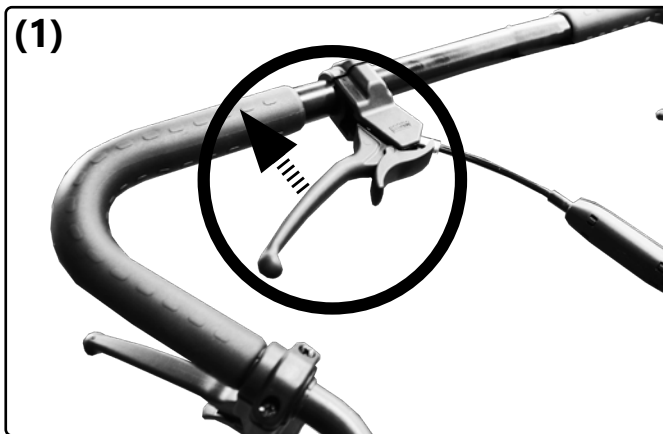

3.4 Handling pushing aids

3.4.1 General information on pushing aids

⚠ All height adjustable pushing aids are only intended to push the occupant in his wheelchair - **not to be carried**.

⚠ Children cannot assess the swivel range of protruding pushing aids and can injure others while playing.

⚠ Before each use of the pushing aids, check the tight lock and the functionality of the star handles. It must not be possible to move the pushing aids in the holder when the star handles are in the closed position.

3.4.2 Push handle

Height adjustment:

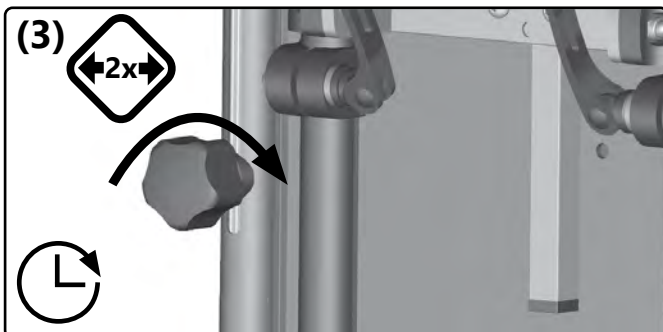
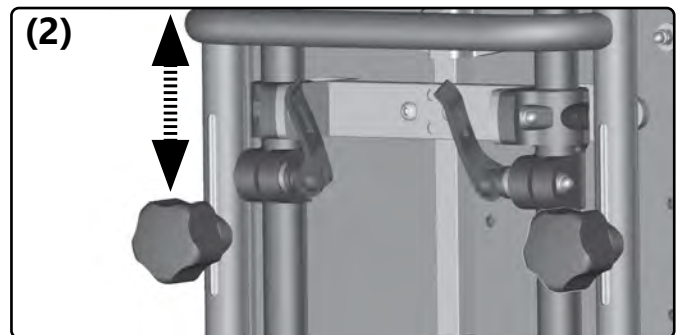
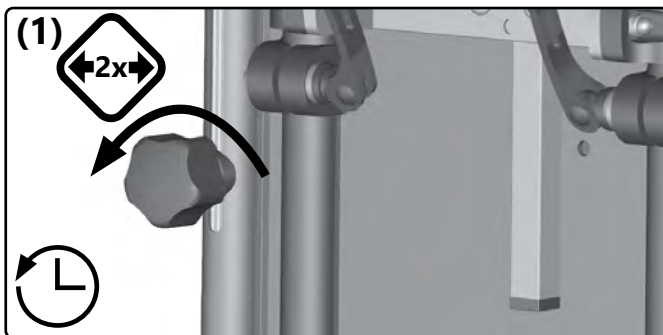

3.4 Handling pushing aids

Adjusting the angle:

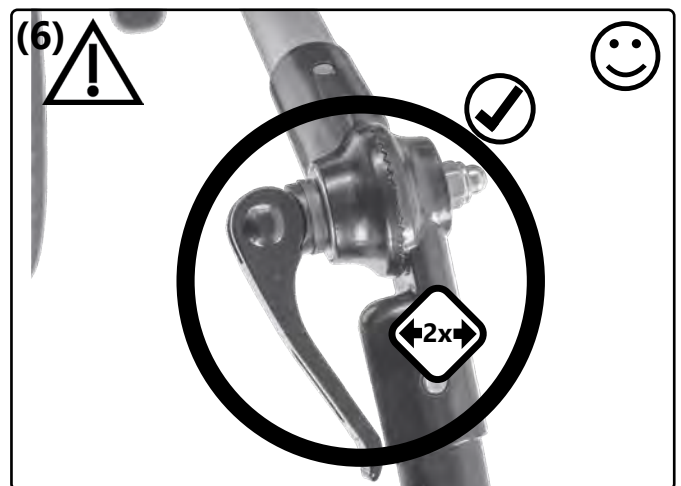
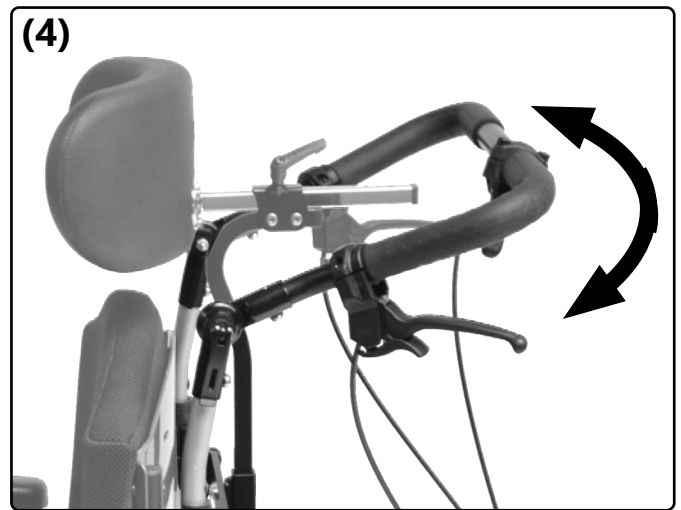
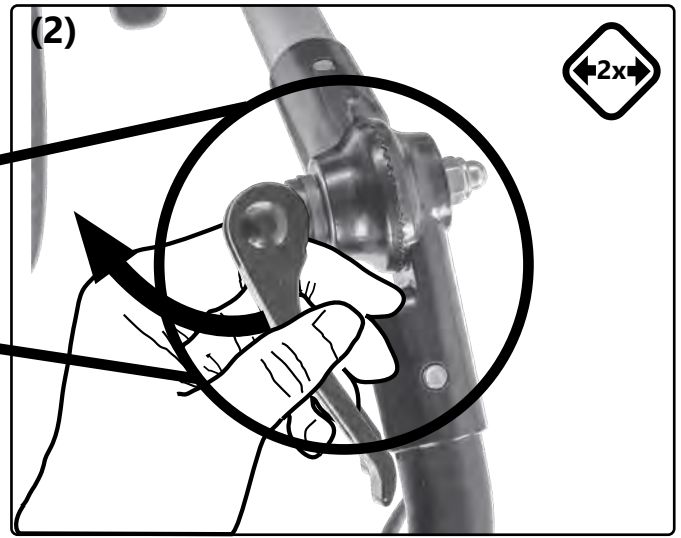
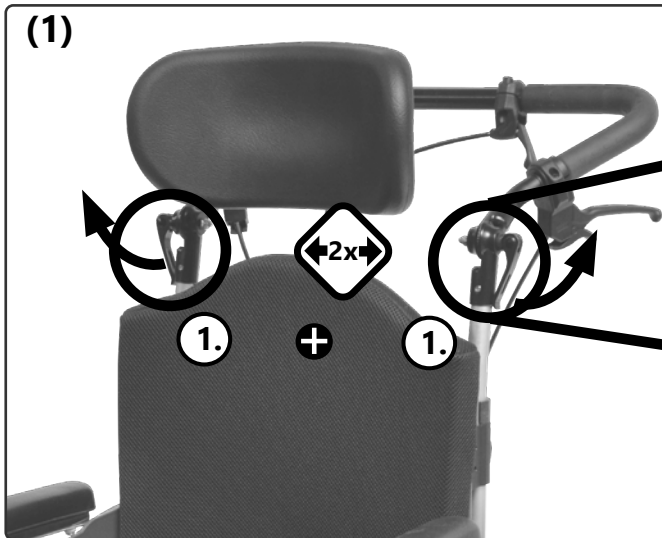

3.5 Using the leg support

3.5.1 General information on leg supports

Types of leg supports:

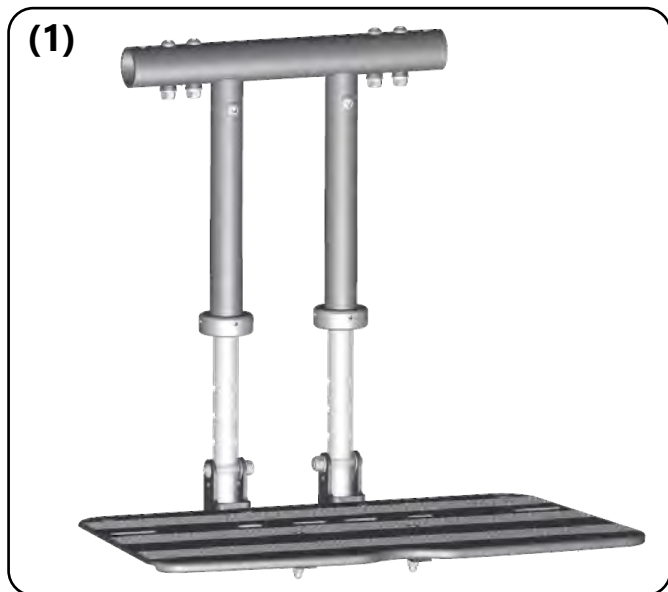

Standard low leg length

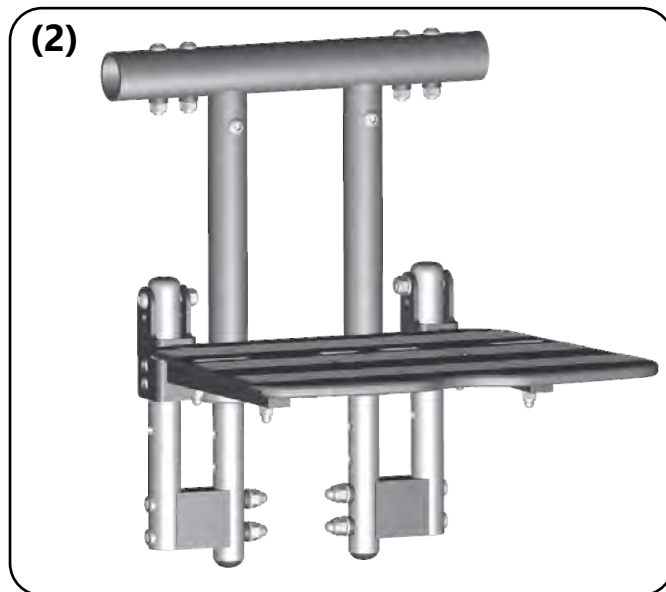

Short lower leg length

3.5.2 Spring-loaded legrest

Locking (unlocking: proceed in the reverse order):

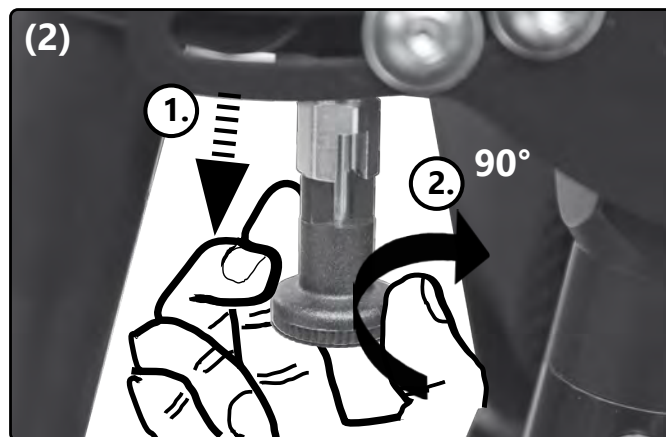
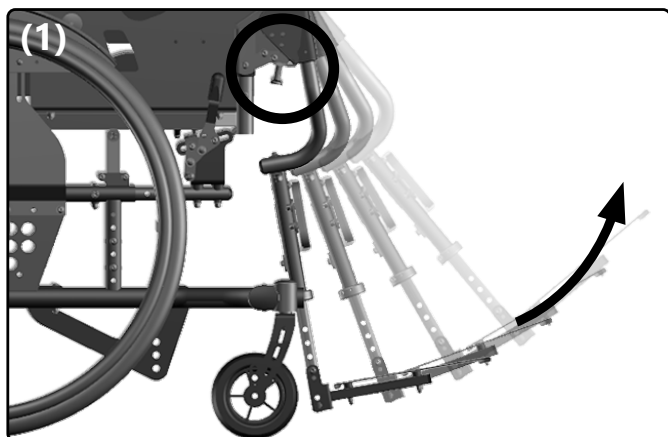

3.5 Using the leg support

3.5.3 Footplate

Locking (unlocking: proceed in the reverse order):

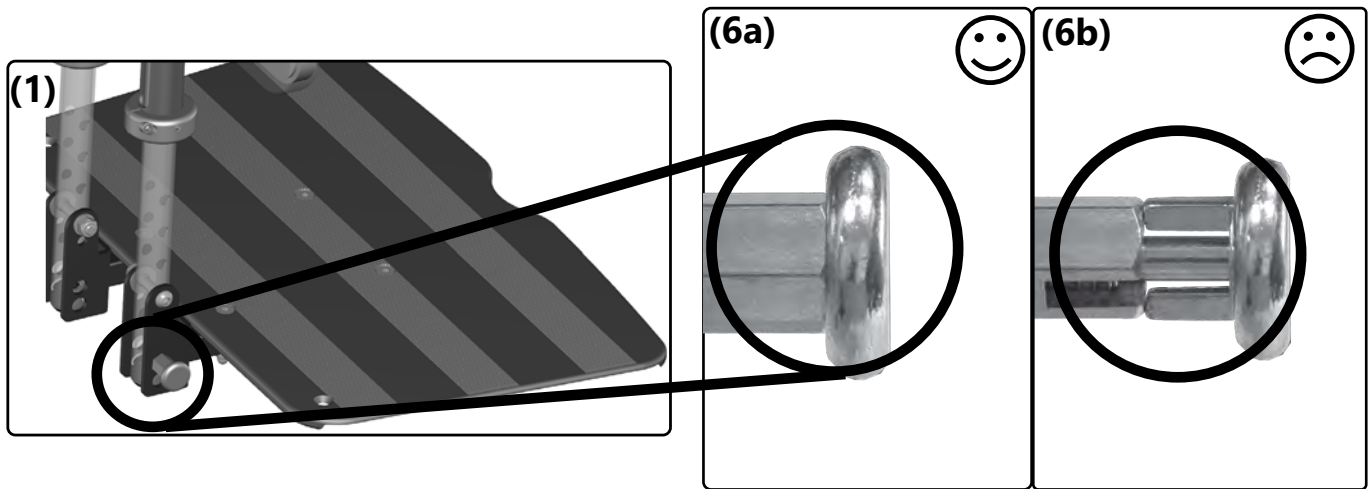

3.6 Handling of the brake system

3.6.1 General information on the brake

Check that the brakes are working properly before every journey! If the braking effect decreases, contact your specialist retailer immediately.

Possible impairments or malfunctions can result from:

- dirty or incorrectly adjusted brakes,
- defective cables,
- the distance between the brake pressure bolt and the tire is too large,
- tire inflation pressure too low (see indication on tyre),
- wetness, snow, mud etc.,
- worn tyres,
- worn or dirty brake pressure bolts.

The wheelchair is not ready for use until any malfunction of the brakes has been rectified.

Always check that the brakes are properly and securely locked on slopes.

3.6.2 Drum brake

Deceleration:



Uneven use of both brake levers causes cornering.

Clean the brake bodies of the drum brake wheels at short intervals with a soft brush.

Locking:

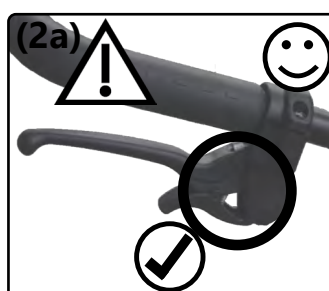
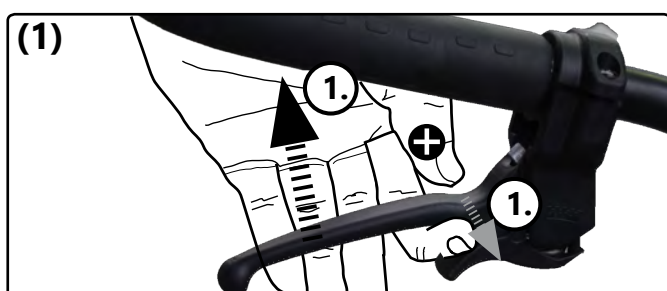

Unlock:



3.6 Handling of the braking system

3.6.3 Locking brake

The knee lever and bowden cable brakes are locking brakes and are not suitable for slowing down the journey.

Locking the knee lever brake:

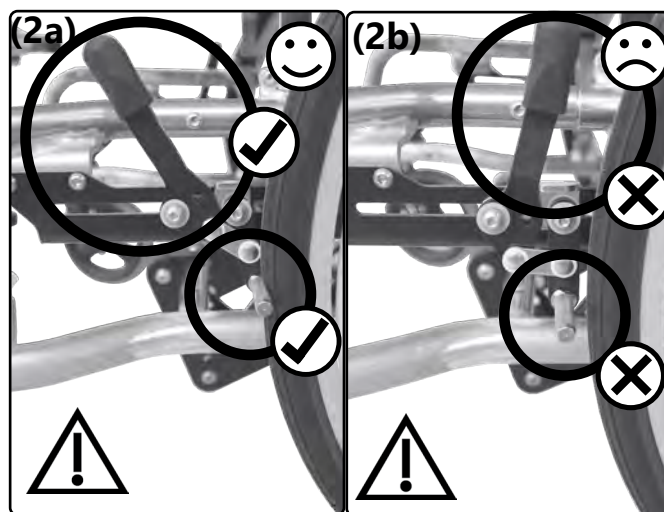
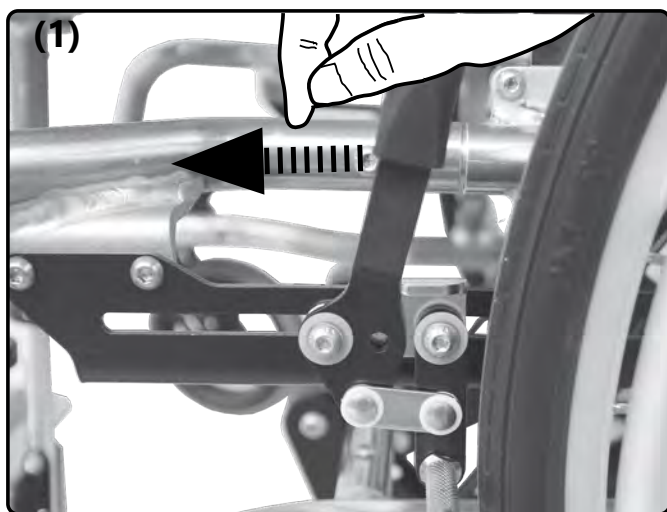

To lock in the open or closed position:

First set the brake in the desired position (locked / unlocked).

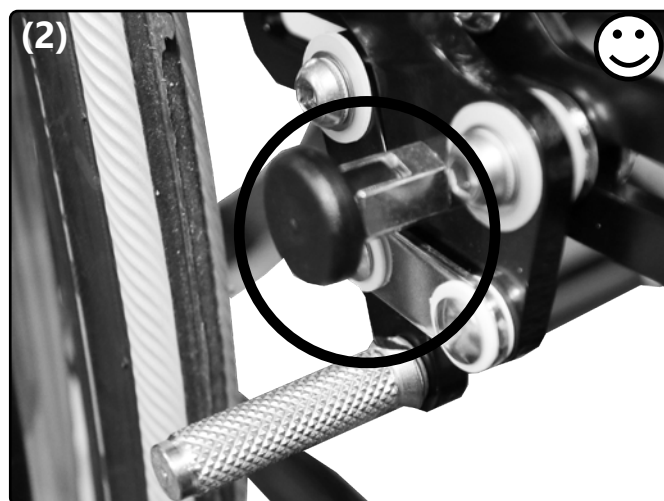
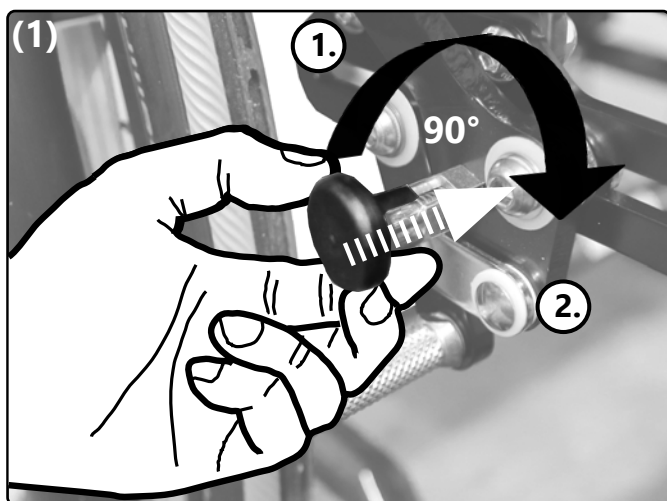

Unlock:

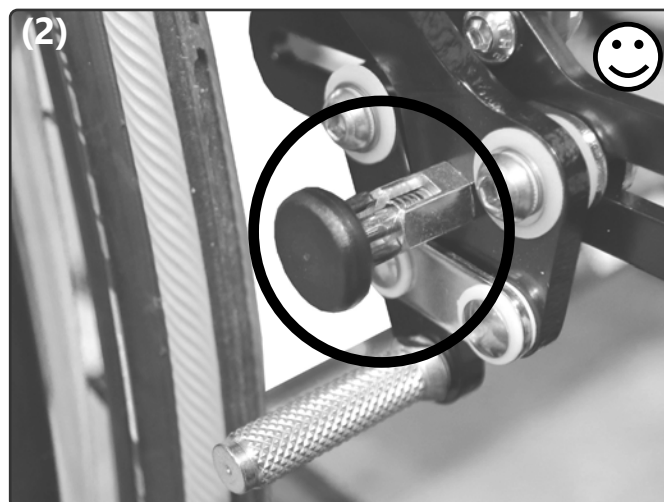
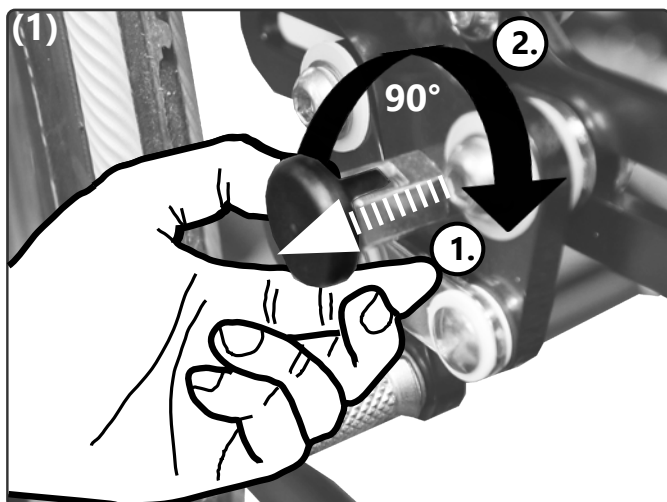

3.7 Handling the anti tipper

3.7.1 General information on the brake

In the case of leg amputations, a wheelbase extension, or at least an anti tipper, should be used to improve the stability against tipping.

A wheelbase extension is **not** a substitute for an anti tipper.

Activate:

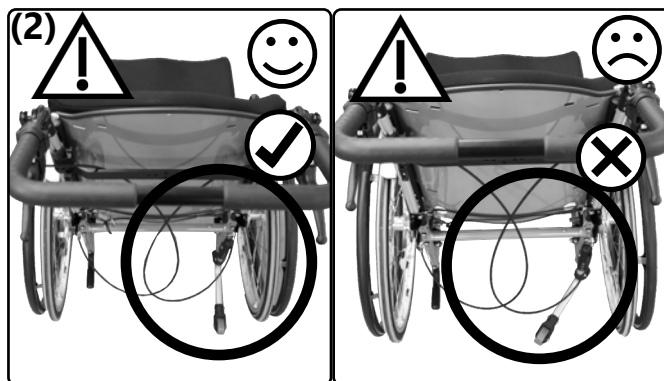
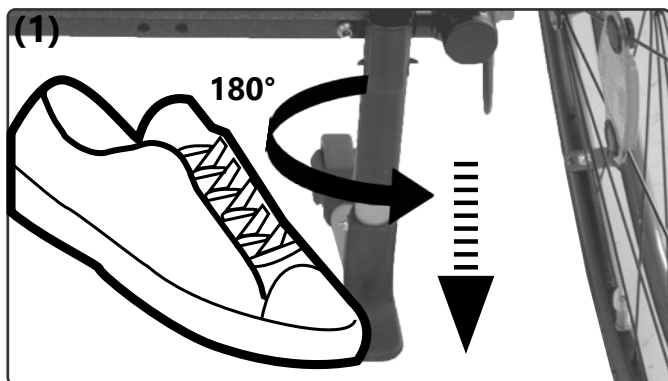

The anti-tipper must always be locked in its end position.

Deactivate:

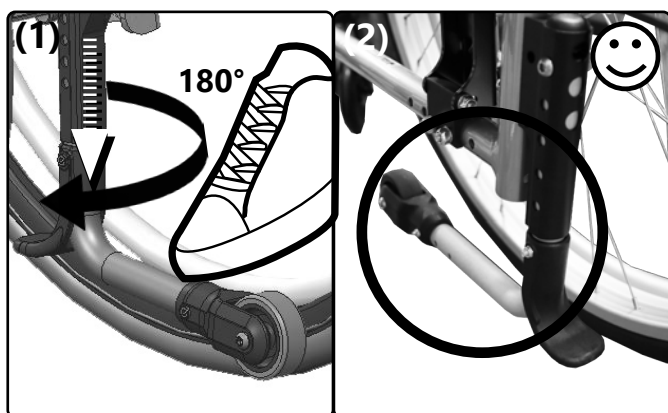

Always turn the anti tipper only 180 ° from the deactivated position to the active position. Avoid full turns in one direction of rotation, otherwise the tension spring inside the anti tipper will be damaged and the anti tipper may lose its functionality.

3.8 Handling the headrest

3.8.1 General information on the headrest

Height adjustable:

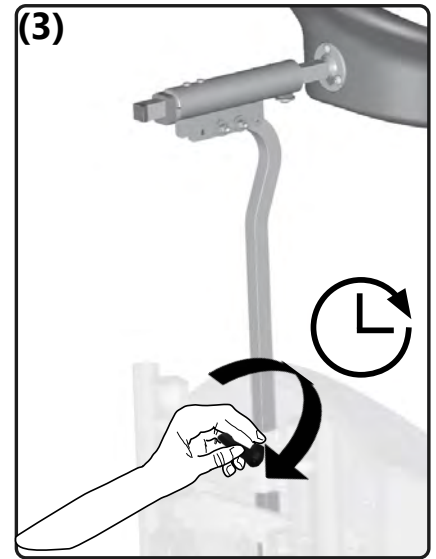
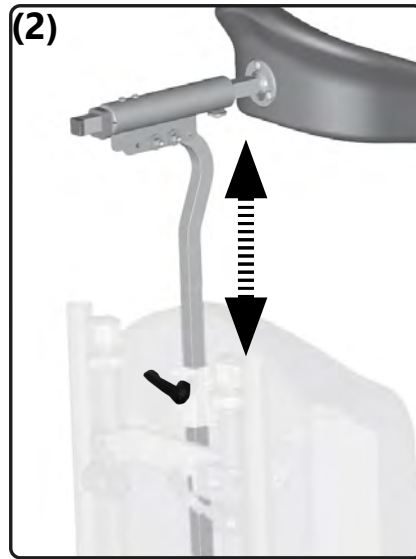
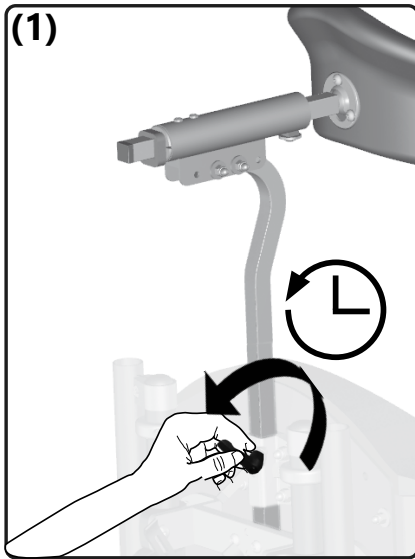

Set the distance (standard headrest):

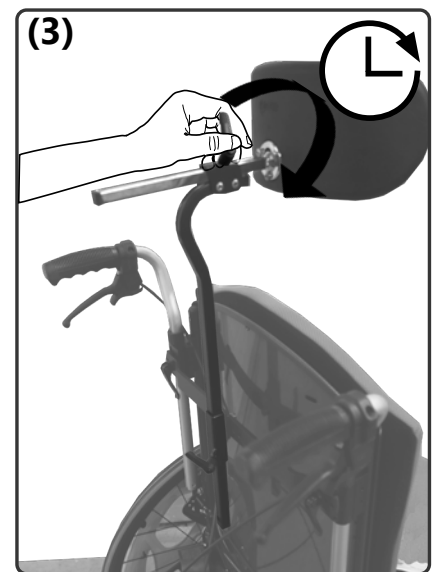
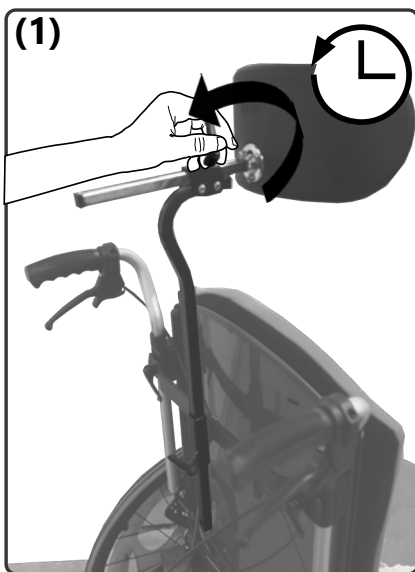

3.9 Handling of the abduction wedge

3.9.1 General information on the abduction wedge

Set the distance:

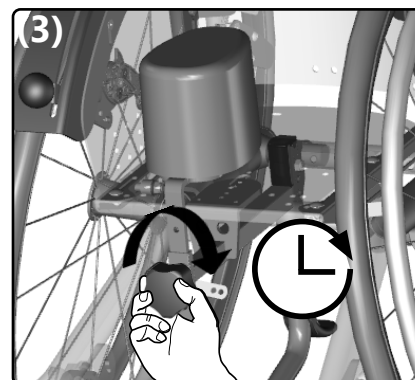
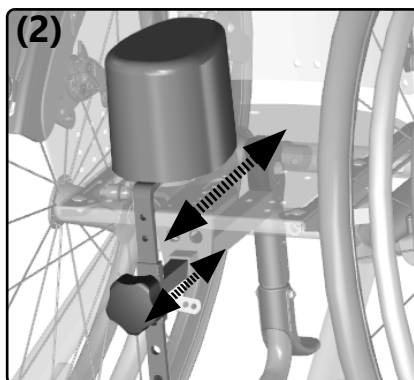
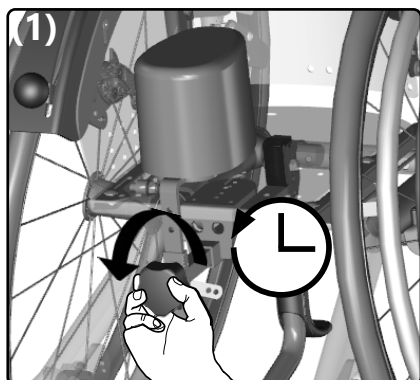

3.10 Handling the therapy table

3.10.1 General information on the therapy table

Adjusting the depth:

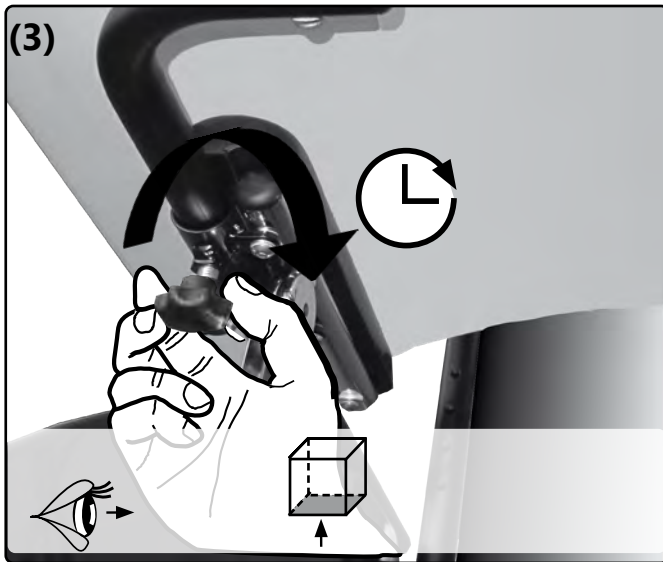
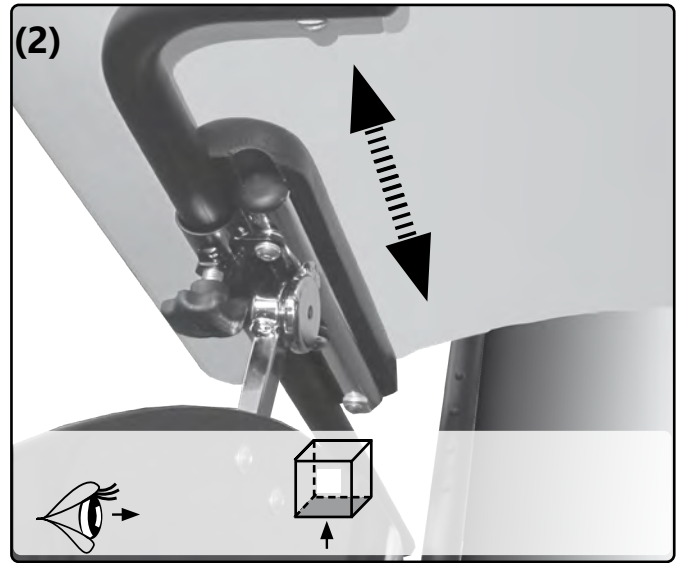
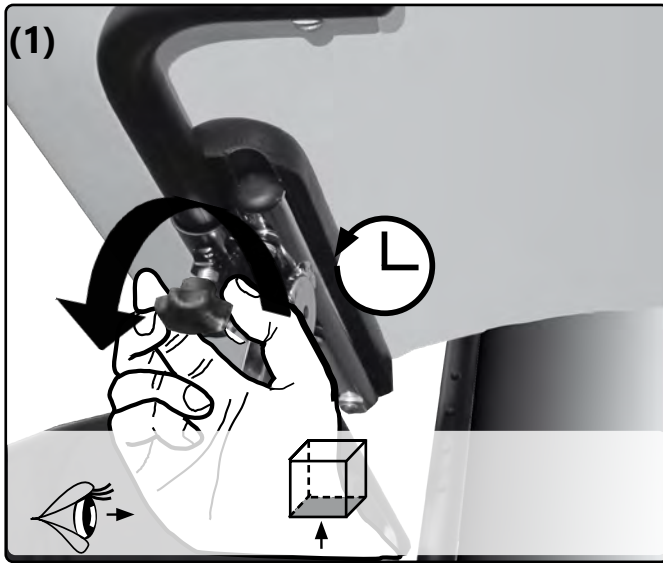

Adjusting the height:

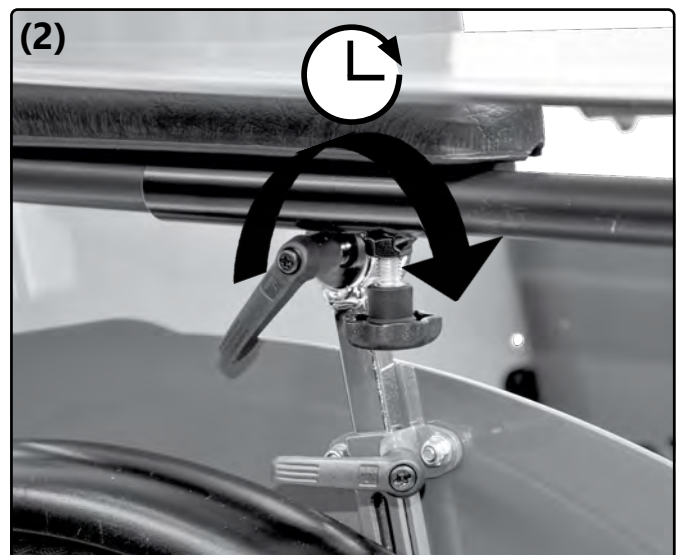
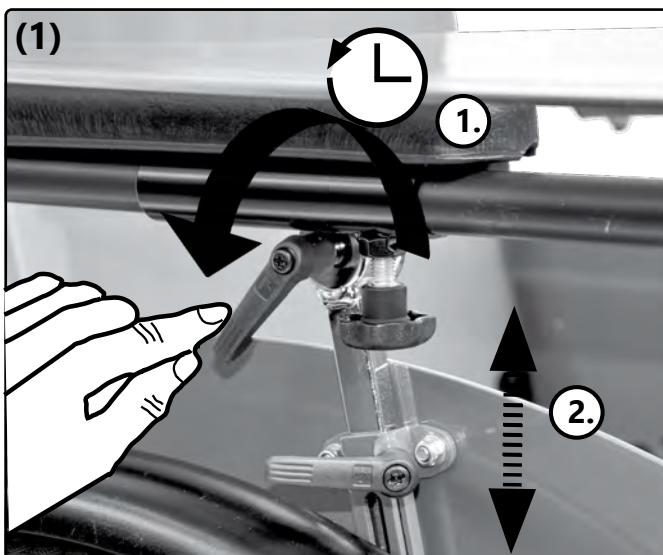

3.11 Armrest handling

3.11.1 General information on armrests

Adjusting the height:

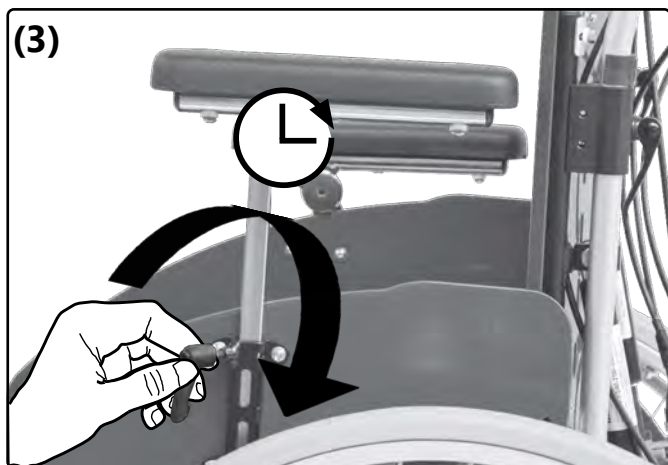
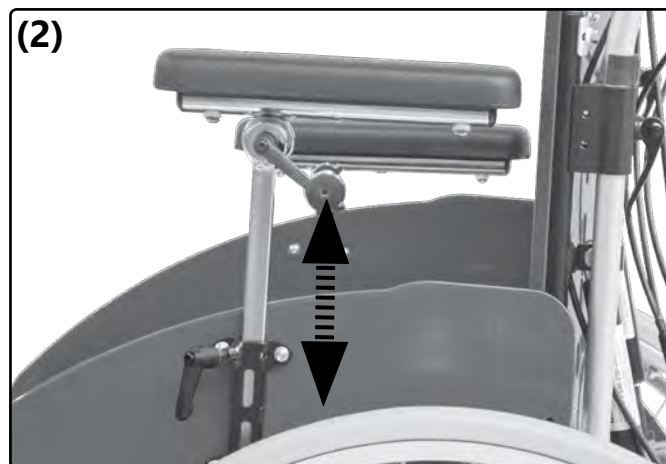
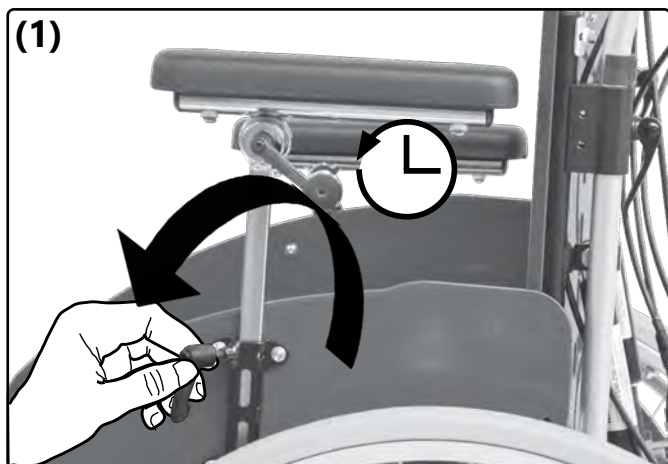

Adjusting the angle:

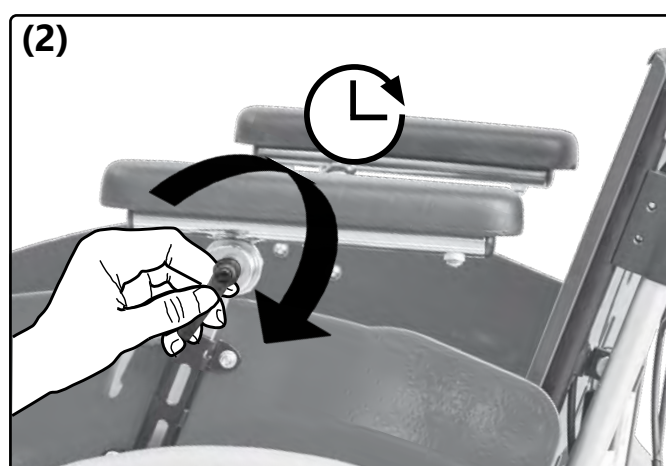
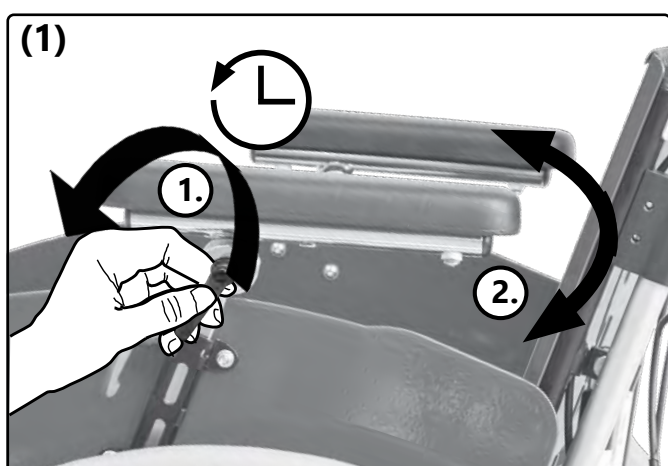

3.12 Handling of the lateral support

3.12.1 General information on lateral support

Open / close:

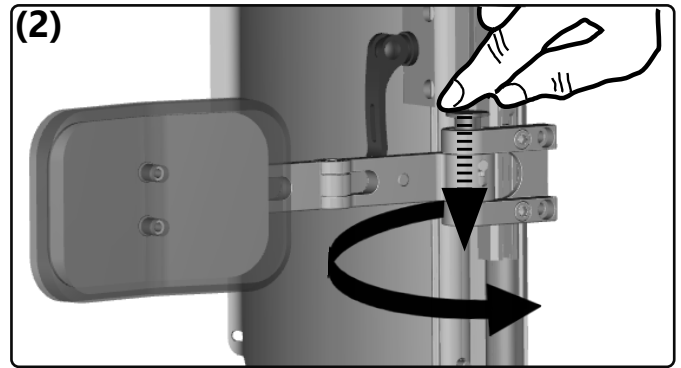
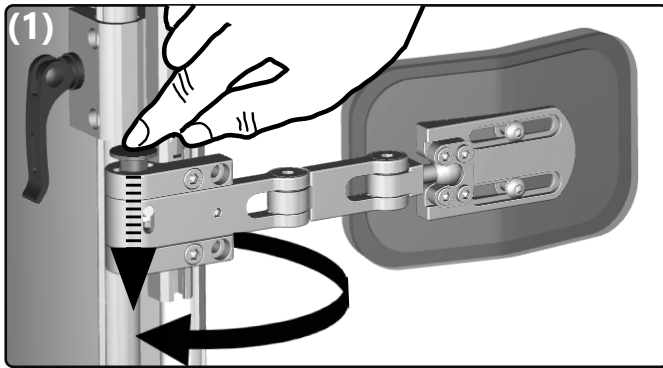

3.13.1 General information on the outdoor-front-end

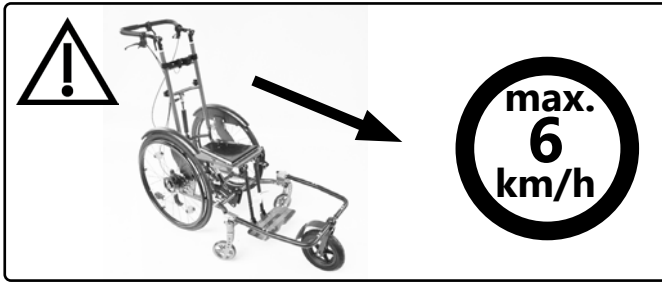

⚠ Note the max. weight capacity of the wheelchair, this also applies to the outdoor-front-end.

Assembly (dismantling: Proceed in the reverse direction in Figure 4):

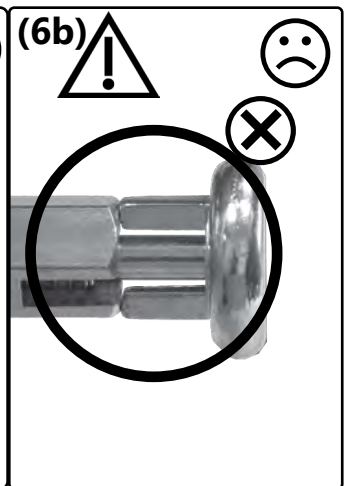
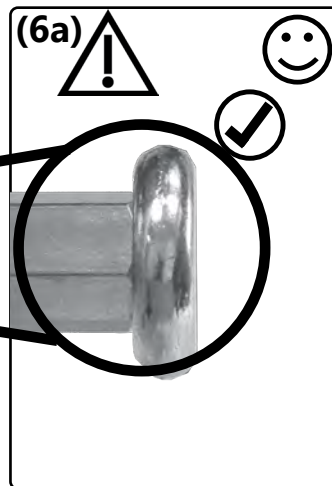
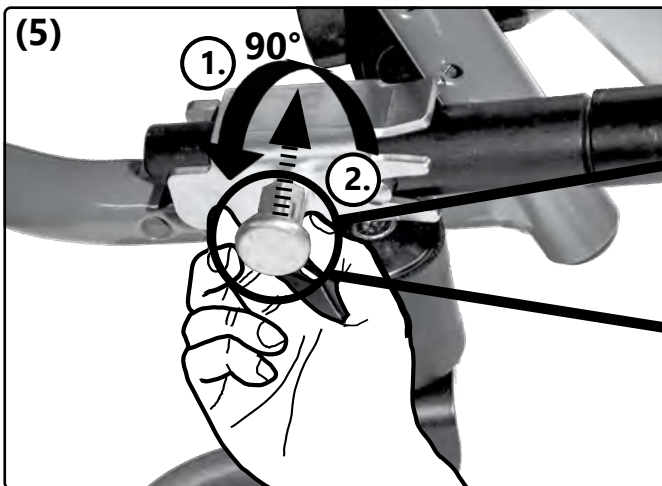
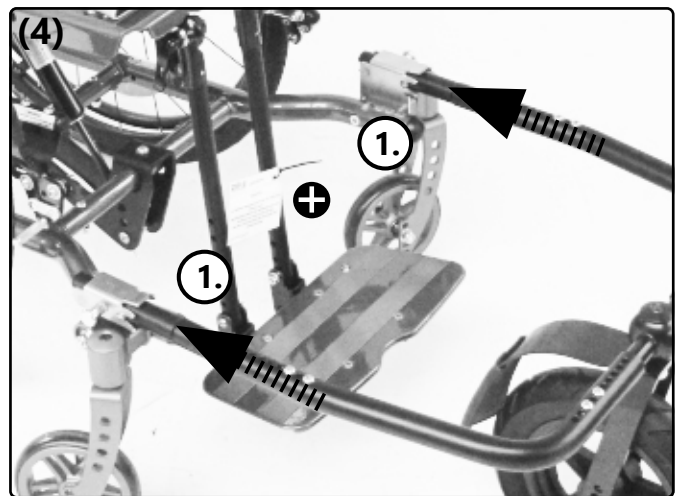
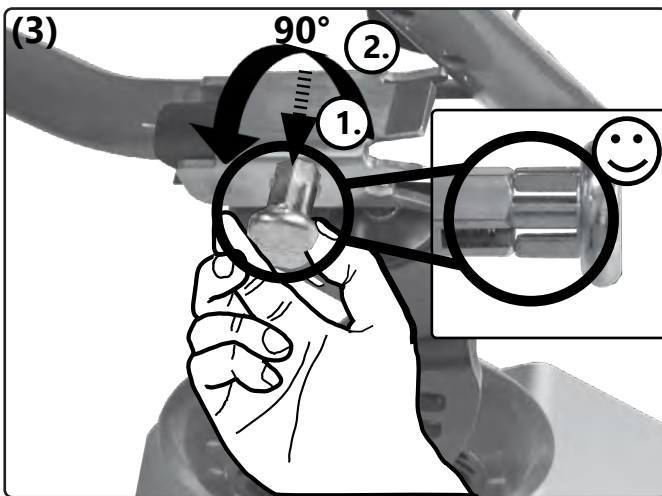
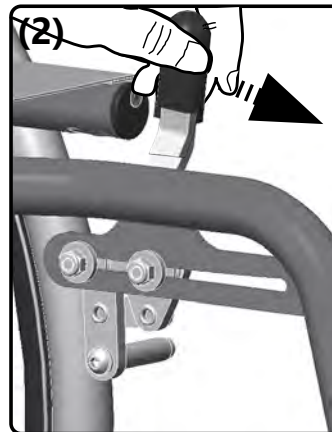
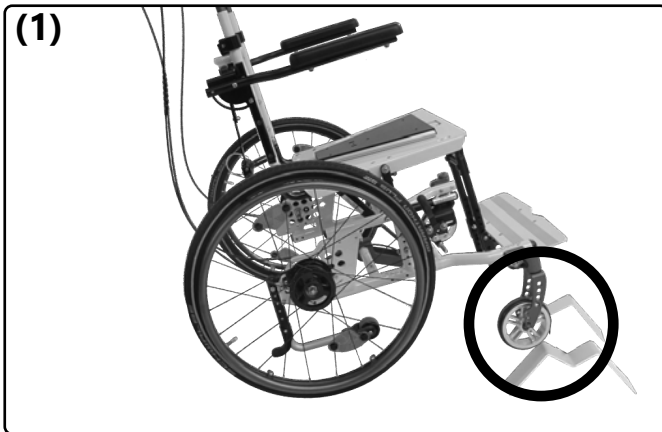

4.1 Repairs

 Repairs are to be carried out by the specialist retailer.

4.2 Spare parts

Only original spare parts may be used. You can obtain these from your specialist retailer.

 The spare parts list can be downloaded from www.sorgrollstuhltechnik.de, or requested from us.

For a correct delivery of spare parts, please specify the serial number of your wheelchair for every order. It is located on the sticker on the frame.

4.3 Cleaning

Regularly clean the wheelchair and all components with a mild household cleaning agent on a water base and then dry it thoroughly.

In addition, clean the drive and steering wheels and remove dirt and contamination (e.g. hair, etc.) from the axles.

Wash textile parts:

Care instructions:

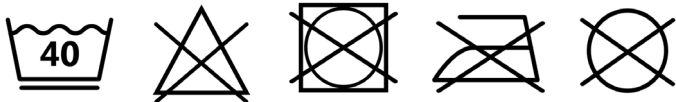

Wipe synthetic leather, straps and other upholstery:

Care instructions:

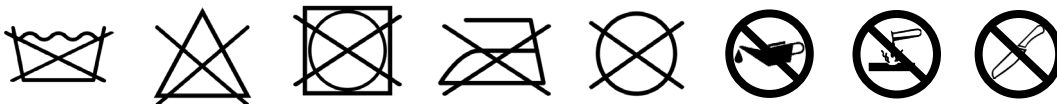

4.4 Disinfection

Cleaning must be carried out before each disinfection. Use a common household water-based agent for disinfection. Observe the application instructions of the respective manufacturer.

4.5 Storage

- Cleaning
- Adjust the seat tilt to 90°
- if necessary, pack removable textile parts in foil or something similar
- secure the wheelchair against rolling away and soiling
- storage in a dry environment without aggressive environmental influences

4.6 Lifespan

The expected normal lifespan, depending on the intensity of use and the number of re-uses, is 5 years. For this purpose, the product must be used for its intended purpose and intended use, the specifications in the instructions for use must be followed and all maintenance and service intervals must be observed.

The product can be used beyond this period if it is in a safe condition. This usual, theoretical service life is not a guaranteed service life and is subject to a case-by-case examination by the specialist retailer, as is the reusability.

Use beyond the specified service life leads to an increase in the residual risks and should only be carried out after careful, qualified consideration by the operator.

The service life can also be shortened depending on the frequency of use, the operating environment and the care.

The usual service life does not refer to wearing parts such as textile parts, wheels and plastic parts that are subject to material-specific aging and / or wear.

This specified service life does not constitute an additional warranty or guarantee.

4.7 Re-use

Before re-use, a complete inspection according to the checklist must be carried out by a qualified specialist retailer. All disinfection measures for re-use must be carried out according to a validated hygiene plan in order to ensure the transfer of a low-germ product.

4.8 Disposal

The wheelchair may only be disposed of with the approval of the sponsor. It must be disposed of in accordance with the applicable national statutory provisions.

4.9 Maintenance / inspection

For safety reasons and to maintain product liability, an inspection by your specialist retailer is required at least once a year. This must be carried out and documented according to the checklist on the following page.

Maintenance and care checklist (user)



Inadequate or neglected maintenance of the wheelchair represents a significant safety

risk.

Before every trip:

Check it:

- Frame, back unit, add-on parts and accessories for visible damage, bends, cracks or missing / loose screws,
- Wheels / axles on tight fit ,
- sufficient tire pressure, tire profile,
- Functionality of the brakes,
- tight fit of the angle adjustment elements / eccentric clamps,
- firm closure of the seat / back / footplate,
- Functionality of the anti-tipper / seat and back straps,
- Whether all previously dismantled parts are reinserted and firmly locked.

Every 3 months:

(earlier depending on usage)

Check:

- Screw connections for tight fit,
- Weld seams, attachments and accessories for hidden damage, bends or cracks,
- Tire tread,
- the firm fit of third-party systems (if available).

Perform a cleaning and oil all moving parts.



If you discover deficiencies during maintenance, please contact your specialist retailer immediately and do not use the wheelchair any more.

Annual inspection checklist (specialist retailer)

Copy template (can be downloaded from www.sorgrollstuhltechnik.de/downloadportal)

To prepare:

- cleaning carried out

Check:

- Frame, back unit, attachments and accessories checked for damage, Bends, cracks and corrosion,
- Checked fastening screws for completeness and tight fit,
- Steering and drive wheels as well as the associated add-on parts checked for condition, functionality and running properties,
- Checked spokes for tight fit and completeness,
- Brakes cleaned and serviced,
- Locking mechanisms (tripod springs of the push handles, quick release axles, eccentric clamps, etc.) checked for functionality,
- Anti tipper checked for tight fit and functionality.

Oil:

- moving parts and bearings are oiled

Final check:

- Functional check of all mechanical adjustment devices carried out

5.1 Data and measurements

Model: Dynamis TSD

HmVz-Nr.:

Type: 804

Dimensions ± 5%

Description		Maße	Bemerkung
Seat width (SW)	Ergo-seat	300 - 500 mm in 20 mm Schritten	+ 40 mm mitwachsend
Seat depth (SD)	Ergo-seat	320 - 520 mm in 20 mm Schritten	+ 20 mm mitwachsend
Back height (BH)	Underframe	430 oder 500 mm	
	Ergo-seat	400-650 mm in 50 mm Schritten	
Back unit:		in der Tiefe um +40/ -20 mm verstellbar	
Seat tilt		-3° bis 30°	
Back angle	Preset	90° / 95° / 100°	
	Dynamic	vom voreingestellten Winkel bis zu 120°	
Lower leg length		220-450 mm	Oberkante Sitzplatte bis Fußplatte
ETRTO wheel size	at 12"	Ø 267 mm (pannensicher) 310 mm luftbereift	
ETRTO wheel size	at 16"	Ø 400 mm	
ETRTO wheel size	at 20"	Ø 451 mm	
ETRTO wheel size	at 22"	Ø 489 mm	
ETRTO wheel size	at 24"	Ø 540 mm	
Hand rim diameter			
	at 20"	Ø 444 mm	
	at 22"	Ø 481 mm	
	at 24"	Ø 533 mm	
Hand rim		Ø 19 mm	Rohrdurchmesser
Camber		0° oder 2°	
Seat height with horizontal seat and a horizontal frame	Seat depth 320 - 340 mm	12": 475 - 515 mm	
	Seat depth 360 - 480 mm	12": 455 - 515 mm 16": 475 - 535 mm 20": 410-515 mm 22": 430-540 mm 24": 460-565 mm	
	Seat depth 500 - 520 mm	16": 495 - 535 mm 20": 430 - 515 mm 22": 450 - 540 mm 24": 480 - 565 mm	
Overall width	min.	RB + 220 mm	
	max.	RB + 320 mm	
overall length	min.	770 mm	Rahmengröße 1 12" Hinterräder
	max.	1200 mm	Rahmengröße 4 24" Hinterräder
Total height (including push handle in 45° position)	min.	1170 mm	RH43 12" Hinterräder
	max.	1400 mm	RH50 24" Hinterräder
Weight capacity	max.	90 kg	
Permissible slope		12% = 7°	bei 0° Kantelung und 0° Neigung des Rückenwinkels
Permissible gradient		12% = 7°	
Security against tipping		12% = 7°	
Turning circle		ca. 1100 mm	abhängig von der Rollstuhlgröße
Individual weights	Wheels	1,2 - 2,2 kg	je nach Ausführung und Größe
Tyres	Commercially available pneumatic tyres (1 " or 1 3/8 " for 12 ") or soli tyres (same dimensions), tyre pressure usually 3-10 bar.		
Corrosion protection	Material	stainless steel, aluminum	
	Coating	powder coating, galvanizing	
Service life	3 years	if the wheelchair is not used excessively	
Lifespan	5 years		
normative requirements	The wheelchair meets the requirements of ISO 7176-8 and the requirements against ignition		
Empty weight min.	suitable for driving with RB 300 mm, 12" wheels, 4" caster wheels PU	24,85 kg	Frame size 1, seat frame, 12" wheels with drum brakes, steering wheels, legrests, push bars.l

5.2 Meaning of the labels

The meaning of the individual labels results directly from the respective text at the relevant place.

If the label is damaged or lost, a new label can be obtained from SORG Rollstuhltechnik.

Label:

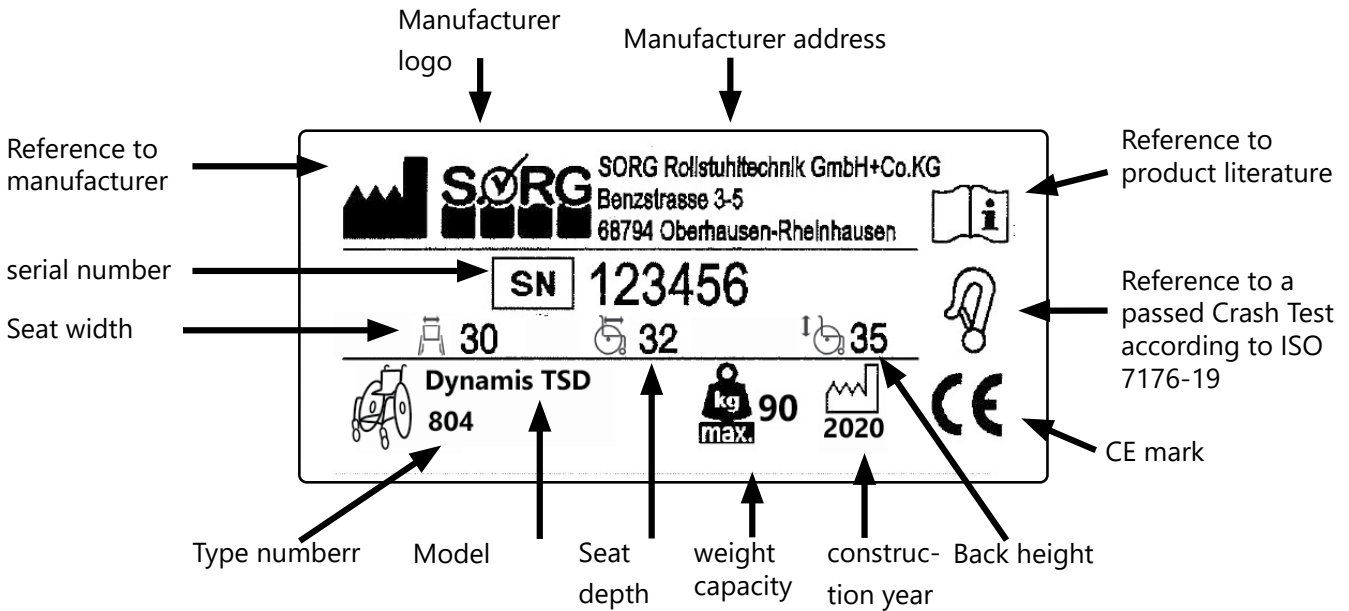

5.3 Declaration of conformity

SORG Rollstuhltechnik declares that the Dynamis TSD product is a class 1 device and that it complies with the relevant provisions of EU Guideline (EU) 2017/745 on medical products.

This has been verified by a conformity assessment procedure in accordance with the medical device guideline.



This declaration loses its validity if changes are made to the product that have not been approved by SORG Rollstuhltechnik.

6 Proof of annual inspection

Documentation annual inspection

For safety reasons and to maintain product liability, an inspection by your specialist retailer is required at least once a year.

Serial number: _____

- annual inspection carried out according to the checklist (operating year 1)

Notes:

company stamp:

Date / Signature of specialist retailer

- annual inspection carried out according to the checklist (operating year 2)

Notes:

company stamp

Date / Signature of specialist retailer

- annual inspection carried out according to the checklist (operating year 3)

Notes:

company stamp:

Date / Signature of specialist retailer

- annual inspection carried out according to the checklist (operating year 4)

Notes:

company stamp:

Date / Signature of specialist retailer

- annual inspection carried out according to the checklist (operating year 5)

Bemerkungen:

company stamp:

Date / Signature of specialist retailer

Instructions for use Dynamis TSD



SORG Rollstuhltechnik GmbH + Co. KG
Benzstraße 3-5
68794 Oberhausen-Rheinhausen
Germany
Fon +49 7254 9279-0
Fax +49 7254 9279-10

export@sorgrollstuhltechnik.de
www.sorgrollstuhltechnik.de

Stamp specialist retailer