

User's Manual

British English

F3 Corpus

CE

Dear Permobil User

We congratulate you on your choice of powered wheelchair. Our goal is for you to continue to feel satisfied with your choice of both vendor and product. Your powered wheelchair is designed to provide the highest possible comfort and safety while meeting both safety and environmental requirements.

Before you begin using your wheelchair, it is important that you read and understand the content of these operating instructions, and in particular the safety instructions.

Produced and published by Permobil

Edition: 8

Date: 2018-07-05

Order no: 334968 eng-UK

How to contact Permobil

Permobil Ltd.
Regus 6th floor
2 Kingdom Street
Paddington
W2 6BD
London
United Kingdom

Tel: (+44) (0)1484 722 888
Fax: (+44) (0)1484 723 013
E-mail: info@permobil.uk

Head office of the Permobil group

Permobil AB
Box 120
861 23 Timrå
Sweden
Tel.: +46 60 59 59 00
Fax: +46 60 57 52 50
E-mail: info@permobil.com
Web: www.permobil.com

1	Important information	11
1.1	Guarantee	12
1.2	Product approval	13
1.3	Technical support.....	13
1.4	Cyber security	13
1.5	Reporting incidents	14
1.6	Spare parts and accessories	14
1.7	Ordering documentation.....	15
1.8	Scrapping and recycling	15
2	Safety instructions	17
2.1	Descriptions of admonitions.....	18
2.2	Warnings and precautions.....	21
3	Getting to know your wheelchair	37
3.1	Overview.....	39
3.2	Technical specifications.....	40
3.3	Design and function	45
3.4	Control panel	63
3.5	Accessories.....	125
3.6	Labels	145
4	Preparing for use	153
4.1	Settings and adjustments.....	155
4.2	Handling and driving	184

4.3	Batteries	201
4.4	Transporting the wheelchair	206
5	Maintenance and repairs	217
5.1	Frequency of maintenance and inspection	221
5.2	Tool bag.....	222
5.3	Cleaning	223
5.4	Battery replacement	225
5.5	Batteries storage	239
5.6	Wheels and tyres	240
5.7	Main circuit breaker	265
5.8	Brake release	266
5.9	Positioning belt	266
5.10	Serial number labels.....	267
6	Approved locking systems	269
7	Restrictions and limitations	271
7.1	Support wheels.....	272
7.2	Speed restriction conditions	274
7.3	Conditions that limit seat movement	275
8	Troubleshooting	277
8.1	Troubleshooting guide	278
8.2	Diagnostics R-net LCD control panel.....	279

8.3	Diagnostics R-net LED control panel	283
8.4	Repairing defective units	288
	Index	289

1 Important information

Before you begin using your wheelchair, it is important that you read and understand the content of these operating instructions, and in particular the safety instructions.

These operating instructions are primarily intended to acquaint you with the functions and characteristics of the wheelchair and how to use them in the best manner possible. They also contain important safety and maintenance information, as well as describing possible problems that can arise while using the wheelchair.

Always keep operating instructions within convenient reach when using your product, as the need for important information may arise concerning its use, safety and maintenance.

It is also possible to obtain information concerning our products from our website: www.permobil.com.

All information, pictures, illustrations and specifications are based upon the product information available at the time these operating instructions were printed. The pictures and illustrations used in these operating instructions are representative examples and not intended to be exact depictions of the various parts of the powered wheelchair.

We reserve the right to make changes to the product without prior notice.

For those who are visually impaired, this document can be downloaded at www.permobil.com. The PDF reader magnifying tool can be used to achieve the desired text and image size.

1.1 Guarantee

All powered wheelchairs are supplied with a two-year product guarantee. Batteries and charger are supplied with a one-year guarantee.

Product Guarantee Information sets forth the conditions of the guarantee. For further information about applicable warranties, see .



NOTICE

Unapproved replacement of parts

If any part is replaced without approval from Permobil, the wheelchair guarantee will become invalid. Permobil accepts no liability for any loss that occurs as a result of a control system component being opened, adjusted or modified without permission.

1.2 Product approval

This product fulfils the requirements according to:

- ANSI/AAMI ES60601-1
- AS/NZS 60335.2.29
- AS/NZS CISPR 14.1
- CAN/CSA-C22.2 No. 60601-1
- EN60601-1
- IEC 60335-2-29
- ISO 7176-21
- ISO 7176-25

1.3 Technical support

In the event of technical problems, contact Permobil.

Be prepared to provide the wheelchair serial number, located on the chassis, to ensure proper support. See [3.6.9 Serial number label](#), Page 151.

1.4 Cyber security

If you discover or suspect that someone unauthorised has tampered with, removed, or replaced a device or data derived from a device, immediately contact Permobil for support.

1.5 Reporting incidents

If an incident occurs, please contact your nearest Permobil representative. This is usually the same person you were in contact with at the time of purchase. To get in touch with your contact, use the link at www.permobil.com. Open your country page and the contact page. The page provides the necessary contact information and a document to help you provide us with the information we need to investigate the incident. Provide as much of the information as possible; it will be of great help to us.

We ask that you submit incident reports to help us improve quality and make sure our product remains safe throughout its service life.

To meet these requirements and to ensure our products remain safe in your hands, we need your assistance. We hope you never need to use the information on this page but in the event of an incident, please contact us.

1.6 Spare parts and accessories

Spare parts and accessories must be ordered through Permobil.

The expected service life of this product is five years.

1.7 Ordering documentation

Should you need another copy of this manual, one may be ordered from Permobil. Ask for the order number specified on the back cover.

1.8 Scrapping and recycling

Contact Permobil for information about scrapping agreements in force.

2 Safety instructions

A powered wheelchair is a motorised vehicle and therefore special care must be taken when using it.

Please read and follow all instructions and warnings in all manuals supplied with your powered wheelchair and its accessories. Incorrect use may both injure the user and damage the wheelchair. In order to reduce these risks, read the User's Manual and all manuals supplied carefully, in particular the safety instructions and their warning texts.

Permobil is not responsible for personal injuries or property damage resulting from any person's failure to follow the warnings and instructions in this manual. Permobil is not responsible for injuries or damage resulting from failure to exercise good judgement.

The final selection and purchasing decision about the type of powered wheelchair to be used is the responsibility of the user and his or her healthcare professional. Permobil is not responsible for inappropriate selections of models, features or improper mountings on the wheelchair.

Your powered wheelchair was configured specifically for your needs as prescribed by your healthcare provider. Contact your healthcare provider to have changes in seat position or other adjustments made.

It is also of the utmost importance that you devote sufficient time to getting acquainted with the various buttons, functions and steering controls; the different seat adjustment possibilities, etc. of your wheelchair and its accessories before you begin using it.

Do not undertake your own first test drive without making sure help is available in the immediate vicinity should you need it.

2.1 Descriptions of admonitions

The following admonitions describing warnings, remarks and explanatory texts are used throughout this manual to draw attention to items of significant importance to safety:



DANGER!

Danger admonition

Indicates a dangerous situation which, if not avoided, could result in death as well as serious damage to the product or other property.

**WARNING!****Warning admonition**

Indicates a hazardous situation which, if not avoided, could result in serious injury or death as well as damage to the product or other property.

**CAUTION!****Caution admonition**

Indicates a hazardous situation which, if not avoided, could result in minor or moderate injury as well as damage to the product or other property.

**NOTICE****Notice admonition**

Indicates an important but not hazardous situation which, if not avoided, could result in damage to the product or other property.

- i** Provides information about the conditions or circumstances under which the information given applies.

2.2 Warnings and precautions



CAUTION!

Operation, driving

If the wheelchair is equipped with lights, Permobil recommends their use whenever you drive near public rights of way. Use extreme caution when driving near unprotected edges, drops or on elevated surfaces. Unintended movement or excessive speed in such areas can lead to personal injury or property damage.



CAUTION!

Operation

Do not drive the wheelchair over any curbs or obstacles higher than specified in the technical specifications section of the manual. When driving over a curb or similarly elevated surface, cross it at a 90-degree angle (perpendicular). Crossing such surfaces at any other angle may result in the wheelchair tipping.

Reduce your speed when driving on uneven terrain or soft surfaces. Never use your wheelchair on stairs or escalators. Always take the lift.

Do not lift or move the wheelchair by any of its removable parts. Doing so could lead to personal injury and property damage, including damage to the wheelchair.

**CAUTION!****Operation, pulling and minor impacts**

Do not use the wheelchair to pull any kind of object and never hang excessive weights on the backrest. Doing so could lead to personal injury and property damage, including damage to the wheelchair.

In the event of a collision with a wall, door or other fixed object when operating the wheelchair, always make sure all parts of the wheelchair are undamaged before operating it again. Failure to do so could lead to personal injury.

**CAUTION!****Operation, adjust seating system for elevations**

Be sure to adjust the position of your seating according to the limitations applicable to the wheelchair concerned before climbing obstacles or driving on uneven surfaces or slopes.

**WARNING!****Risk of tipping over**

Do not allow the leg support to hit the ground when climbing obstacles, driving on uneven surfaces or slopes or when a slope levels out. Make sure there is sufficient ground clearance to avoid the risk of tipping over.

**CAUTION!****Operation**

Do not let children drive the wheelchair without supervision. Do not drive the wheelchair on public streets or roads. Obey all local pedestrian rules and be aware that vehicle drivers may have difficulty seeing you.

Do not operate your wheelchair under the influence of alcohol. Consumption of alcohol may impair your ability to operate your wheelchair safely.

Some physical impairments or the use of prescription and non-prescription medication may limit your ability to operate your wheelchair safely. Be sure to consult with your physician about your physical limitations and medications.

**WARNING!****Modifications**

Do not modify your wheelchair or any of its components. Your wheelchair has been configured specifically for your needs as prescribed by your healthcare provider. Special skills, training and knowledge are needed to set up, modify and repair the wheelchair.

Initial setup and all modifications and repairs must be performed by a qualified service technician. For guarantee service, contact the dealer from whom the wheelchair was purchased.

**WARNING!****Do not alter safety parameters**

The wheelchair is equipped with certain safety parameters that limit or inhibit wheelchair functions or, under certain conditions, prevent the wheelchair from being driven. Do not alter these safety parameters.

**WARNING!****Weight limitations**

The maximum user weight for your wheelchair is set forth in the technical specifications section in this user manual. Operation of the wheelchair by users who exceed the maximum allowable user weight can lead to personal injury and property damage, including damage to the wheelchair, as well as voiding any guarantee applicable to the wheelchair.

Do not carry passengers on the wheelchair. Doing so can lead to personal injury and property damage, including damage to the wheelchair.

**CAUTION!****Prior to riding**

In some instances, including where certain medical conditions exist, users should practise operating their wheelchair under the supervision of an assistant who is familiar with the operation of the wheelchair and with the abilities and limitations of the user.

**CAUTION!****Operation - slopes**

When driving downhill, select the slowest speed and proceed with caution. Driving down a slope may shift the user's centre of gravity forward. If the wheelchair rolls faster than you would like, stop the wheelchair by releasing the joystick and begin descending again more slowly.

Avoid sudden stops or starts. Stop by releasing the joystick rather than by turning the power off. Turning off the power while the wheelchair is in motion will cause the wheelchair to stop suddenly. Permobil recommends the use of securely fastened positioning belts at all times.

When driving up a slope, try to keep moving at a steady speed. Stopping and starting the wheelchair while moving up a slope makes the wheelchair more difficult to control.

Do not drive up or down slopes with gradients greater than those set forth in the technical specifications section of this User's Manual. There is a risk that the wheelchair will not manoeuvre safely.

**WARNING!****Operation - inclines**

Do not drive the wheelchair where the sideways gradient is greater than that set forth in the technical specifications section of this User's Manual. There is a risk of tipping over.

Do not drive up or down ramps that are not equipped with proper edge protection along the sides to prevent the wheelchair from falling off the ramp.

When driving up an incline, be sure to drive the wheelchair straight up the incline (perpendicular). Driving up an incline at an angle increases the risk of tipping or falling. Use extreme caution when driving up inclines.

Do not drive up or down hazardous inclines such as a surface covered with snow, ice, or wet leaves, or a surface that is uneven. Also avoid driving on ramps that do not have proper edge protection.

**WARNING!****Operation - turning**

Turning your wheelchair at high speeds may cause it to topple with personal injury as a result. The risk of tipping over is increased by high turning speeds, sharp turns, uneven surfaces, abrupt changes in direction, and driving from an area of low traction (e.g. lawn) to an area of high traction (e.g. pavement).

To avoid tipping over, personal injury and property damage, reduce speed and turn less sharply.

**WARNING!****Operation - free-wheel mode**

In order to prevent the wheelchair from rolling away, make sure it is on a level surface before releasing the brakes.

To avoid personal injury, do not use your wheelchair in free-wheel mode without an attendant present. Do not attempt to put the wheelchair in free-wheel mode yourself while sitting in it.

Do not put your wheelchair in free-wheel mode while on an incline. This may cause the wheelchair to roll on its own, causing injury and property damage, including damage to the wheelchair.

**CAUTION!****Driving range**

The driving range stated in the technical specifications of this manual represents the theoretical driving range when testing the wheelchair according to EN12184 and ISO 7176-4. This test is performed under ideal conditions and actual driving ranges will vary depending on battery status, tyre selection and driving conditions. Frequent driving on slopes, rough ground or frequently climbing curbs etc. will also reduce the driving range.

**CAUTION!****Driving in the dark**

Driving in the dark is only permissible if the wheelchair is equipped with functioning lighting at the front and rear, or as per applicable national or local traffic regulations.

**WARNING!****Passengers**

The wheelchair is not intended to carry passengers, regardless of the age of the passenger. The maximum user weight for your seating system is stated in the technical specifications section of this User's Manual. The stated user weight includes the user and any personal effects. The maximum limit may not be exceeded. The wheelchair's manoeuvrability and stability can be degraded as a result.

**WARNING!****Driving with seat lift, seat tilt, backrest recline**

Make absolutely sure that nothing gets stuck between the chassis and the seat when the seat lift and/or seat tilt is operated. Operating the seat lift, seat tilt and/or backrest recline changes the centre of gravity and increases the risk of tipping over. Always drive at low speed and only use these seat functions on level ground – not on hills, ramps, slopes or other inclines. Using these seat functions while driving on inclines may lead to personal injury and property damage, including damage to the wheelchair.

**WARNING!****Centre of balance**

The likelihood of the wheelchair tipping and the point at which the wheelchair will tip forward, backward or to the side depends on its centre of balance. Note that the following factors affect the wheelchair's centre of balance:

- Elevation of the seat.
- Height and angle of the seat.
- Body position or weight distribution.
- Driving on an incline such as a ramp or a hill.
- The use of a rucksack or other accessories, depending on the amount of weight added.

If the wheelchair begins to move in an unexpected manner, release the joystick immediately to stop the wheelchair. Except in an emergency, do NOT use the On/Off button to stop the wheelchair, as this will cause the wheelchair to stop abruptly which may cause personal injury.

**WARNING!****Fixed seat post**

Only authorised service providers may adjust seat height.

**WARNING!****Use installed positioning aids**

The user must use and securely fasten the positioning belt and any other positioning aids on the wheelchair. Failure to properly use positioning belts and other positioning aids may cause bodily injury. If there is any sign of damage or wear on any positioning belt or aids, immediately contact Permobil for a replacement.

**WARNING!****Support wheels**

If the wheelchair is equipped with support wheels, they must always be fitted when the wheelchair is being driven.

**WARNING!****Transfer into and out of the wheelchair**

Make sure the power is turned off before getting into or out of the wheelchair and before lifting the control side armrest.

When transferring into or out of the wheelchair, every precaution must be taken to reduce the distance between the wheelchair and the place to which the user is transferring. Too great a distance may cause the user to overexert him or herself, lose balance or fall.

Permobil recommends that users transfer in the presence of or with the assistance of an attendant.

Use caution when bending or reaching.

Never use the joystick as a handle or support.

Do not use footplates or armrests as supports when transferring into or out of the wheelchair. The footplates and armrests are not designed as load-bearing structures. Excessive force may cause them to give way, resulting in personal injury or property damage, including damage to the wheelchair.

**NOTICE****Transporting the wheelchair**

The wheelchair may only be transported in vehicles approved for this purpose. The vehicle must be suitably designed, insured and equipped to transport a person in a wheelchair. No matter how securely it is fastened in the vehicle, a wheelchair is not designed to be a car seat and cannot offer the same degree of safety as offered by standard car seats.

Before transportation, check that the wheelchair is properly secured and that both wheel locks are engaged. Secure the wheelchair front and rear to the vehicle at the tie-down points only (marked with yellow stickers). Follow the manufacturer's instructions supplied with the approved fastening straps.

Instead of fastening straps, the wheelchair may be secured with a locking system approved by Permobil for the product concerned.

For alternative vehicle securement options, please consult your dealer.

**WARNING!****Wheelchair must be facing forward**

The wheelchair is designed to be facing forward when used as a seat in a motor vehicle.

**CAUTION!****Damage during transportation**

It is extremely important to inform Permobil as soon as possible after the event if the wheelchair and its accessories have suffered transportation damage, damage during driving or damage from other causes. There is a risk that the wheelchair and its accessories can no longer be used safely and securely. Contact your service provider or Permobil for further information. Refer to page 5.

**DANGER!****User transportation in wheelchair**

When the user is seated in the wheelchair during transport, the following requirements must be met:

- The vehicle must be equipped with a locking system approved by Permobil for the product concerned. For alternative vehicle securement options, please consult your dealer.
- The locking system must be dimensioned for the total weight of the wheelchair.
- The user must use a three-point seatbelt attached to the vehicle.
- The wheelchair must be crash tested and approved.
- The wheelchair must be fitted with a headrest during transit.
- Alterations or substitutions should not be made to wheelchair securement points, structural parts, frame parts or components without consulting Permobil or the dealer.
- Spill-proof sealed batteries, such as gel or AGM, must be used.
- Make sure that wheelchair components do not accidentally press down the seatbelt's release button.

If these requirements are not followed, the user can sustain bodily injuries or die.

**WARNING!****Positioning belts and aids are not vehicle seatbelts**

The wheelchair positioning belt and aids are designed to properly position the user in the wheelchair for safely operating the wheelchair. The wheelchair positioning belts and aids do not provide protection in a traffic accident and do not replace a vehicle mounted seatbelt.

**WARNING!****Secure loose objects during transportation**

Auxiliary wheelchair equipment, loose or mounted on the wheelchair, must either be secured to the wheelchair or removed from it. Dismantled or movable auxiliary equipment must be properly secured in the vehicle during transit. This is to prevent loose parts or parts that may come loose from causing injury to the occupants during transit.

**CAUTION!****Driving in extreme weather conditions**

Our wheelchairs are designed to withstand most adverse weather conditions. However, to minimise the risk of being caught in difficult situations, you should avoid using the wheelchair outdoors in e.g. severe cold, heavy rain or thick snow.

Also bear in mind that certain surfaces on the wheelchair can get very hot or cold in the event of prolonged exposure to intense sunlight or cold.

**WARNING!****Environmental conditions**

Protect the wheelchair from exposure to any type of moisture, including rain, snow, mud or spray. Exposure to moisture may cause the chair to short-circuit, catch fire and cause personal injury or property damage. If it has been exposed to moisture, do not operate your wheelchair until it has dried completely.

If any of the covers or the joystick boot has cracks or tears, it must be replaced immediately. Failure to do so may allow moisture to enter the electronics and cause personal injury or property damage, including fire.

Be extremely careful when operating your wheelchair in icy or slippery conditions. Such conditions can lower the performance and safety of your wheelchair which could lead to an accident, personal injury and property damage, including damage to the wheelchair.

Exercise extreme caution when using oxygen in close proximity to electrical circuits and other combustible materials. Contact your oxygen supplier for instruction in the use of oxygen.

**CAUTION!****Maintenance and service**

Only carry out the minor adjustments and maintenance specified in the User's Manual.

All other service, repairs and maintenance on Permobil products, including control system programming, must be performed by a qualified service technician authorised by Permobil. Incorrect settings may result in unsafe operation of the wheelchair and cause it to become unstable or uncontrollable. Such modifications may also render the product's guarantee invalid.

**CAUTION!****Non-approved aftermarket accessories**

Do not use parts or accessories not authorised by Permobil.

The use of non-approved aftermarket accessories and parts may cause changes in the wheelchair that make it unstable or uncontrollable.

The product guarantee may be voided if unauthorised parts or accessories are used.

**CAUTION!****Non-approved electrical or electronic devices**

Connecting non-approved electrical or electronic devices to the wheelchair's electrical system may cause damage to the wheelchair and make it uncontrollable or erratic. Such use may also render the guarantee invalid.

**CAUTION!****Risk of getting caught in crush points**

The wheelchair is heavy and contains many moving parts, which means there is an ever-present risk of getting caught in pinch points.

**WARNING!****Charging batteries**

Charge batteries in a well-ventilated room, not in a wardrobe or cupboard. Batteries must not be charged in a bathroom or wet room. Only use chargers with maximum 10 A charging current (average value). The charging current RMS value must not exceed 12 A. When the charger is connected, the wheelchair cannot, and may not, be driven.

**WARNING!****Replacing batteries and circuit breakers**

Always turn the main circuit breaker to the Off position when replacing batteries or circuit breakers.

Exercise caution when using metallic objects during work with batteries. A short-circuit can easily cause an explosion. Always use protective gloves and goggles.

**WARNING!****Safety circuits**

The products are equipped with safety circuits. Inhibit circuits prevent the wheelchair from being driven under certain conditions. Speed reduction circuits limit the wheelchair's maximum speed under certain conditions. Limit switch circuits limit the wheelchair's functions under certain conditions. Overload protection circuits switch the wheelchair off in the event of overload. If any of these circuits stops working, stop using the wheelchair immediately and consult an authorised Permobil distributor.

Any attempt to modify the safety circuits will result in unsafe wheelchair operation and may cause the chair to become unstable or uncontrollable. Such modifications may also render the wheelchair's guarantee invalid.

**CAUTION!****Recycling batteries**

Used or malfunctioning batteries must be disposed of responsibly in accordance with local recycling regulations.

**WARNING!****Inflating tyres**

Regularly check that the wheelchair's tyres have the correct pressure. Incorrect tyre pressure may cause stability and manoeuvrability to deteriorate.

**NOTICE****Changing tyres**

Avoid the use of sharp-edged tools when working with tyres.

**NOTICE****Storage**

Always turn off the wheelchair and its accessories when it is not in use. Always store the wheelchair so that access for unauthorised individuals is prevented.

Never store the wheelchair in a room where there is a risk of condensation (mist or moisture on surfaces) e.g. in pool areas, laundry rooms or similar.

If you are unsure how your wheelchair and its accessories should be properly stored, contact your supplier or Permobil for more information.

**WARNING!****Damage and/or malfunctions**

If you feel the wheelchair is not behaving as it should in any regard or if you suspect that something is wrong, stop driving as soon as possible, switch off the wheelchair and contact your service provider or Permobil for further information. Refer to page 5.

**WARNING!****Flame resistance**

Fabric components have been tested for flammability. Padded parts meet the requirements of EN 1021-1, EN 1021-2 and ISO 7176-16. Plastic parts meet the requirements of UL94.

**CAUTION!****EMC requirements**

The electronics in a power wheelchair can be affected by external electromagnetic fields (e. g. from cell phones). Similarly, the electronics in the wheelchair itself also emit electromagnetic fields that may affect the immediate surroundings (e.g. certain alarm systems in businesses).

The Electromagnetic Compatibility (EMC) limit values with respect to powered wheelchairs are set forth in the harmonised standards for the EU in the Medical Devices Directive, No. 93/42/EEC.

Our powered wheelchairs comply with these limit values.

**WARNING!****Discontinue use following a serious accident**

Stop using your wheelchair if it has been subject to flooding, fire, dropping, crushing or any impact event including a vehicular accident. Extraordinary events like these can lead to significant damage that is impossible to detect upon inspection.

Damage caused by these types of incidents exceeds the limits covered by the manufacturer's guarantee.

For further information, contact Permobil AB to get in contact with a technical service supervisor.

3 Getting to know your wheelchair

3.1	Overview	39
3.2	Technical specifications	40
3.2.1	Dimensions and weight	41
3.2.2	Performance	43
3.2.3	Wheels	43
3.2.4	Electronics	44
3.2.5	Batteries	44
3.2.6	Control force	44
3.2.7	Circuit breakers	44
3.2.8	Power adjustable leg length	44
3.3	Design and function	45
3.3.1	Seat	45
3.3.2	Chassis	58
3.4	Control panel	63
3.4.1	R-net LCD control panel	63
3.4.2	Joystick panel, R-net LED control panel	110
3.4.3	ICS seat control panel	117
3.5	Accessories	125
3.5.1	ConnectMe	126

3.6	Labels	145
3.6.1	Read the instructions.....	146
3.6.2	Main circuit breaker also battery isolator.....	146
3.6.3	Wheel locks	147
3.6.4	Tie-down point	147
3.6.5	Support wheels.....	148
3.6.6	Crush hazard	148
3.6.7	Warning	149
3.6.8	Battery connections and main circuit breaker	150
3.6.9	Serial number label.....	151

3.1 Overview



1. Backrest
2. Control panel
3. Seat
4. Support wheel
5. Leg support
6. Footplates
7. Headrest
8. Armrest
9. Chassis
10. Serial number label
11. Castor wheels
12. Drive wheels

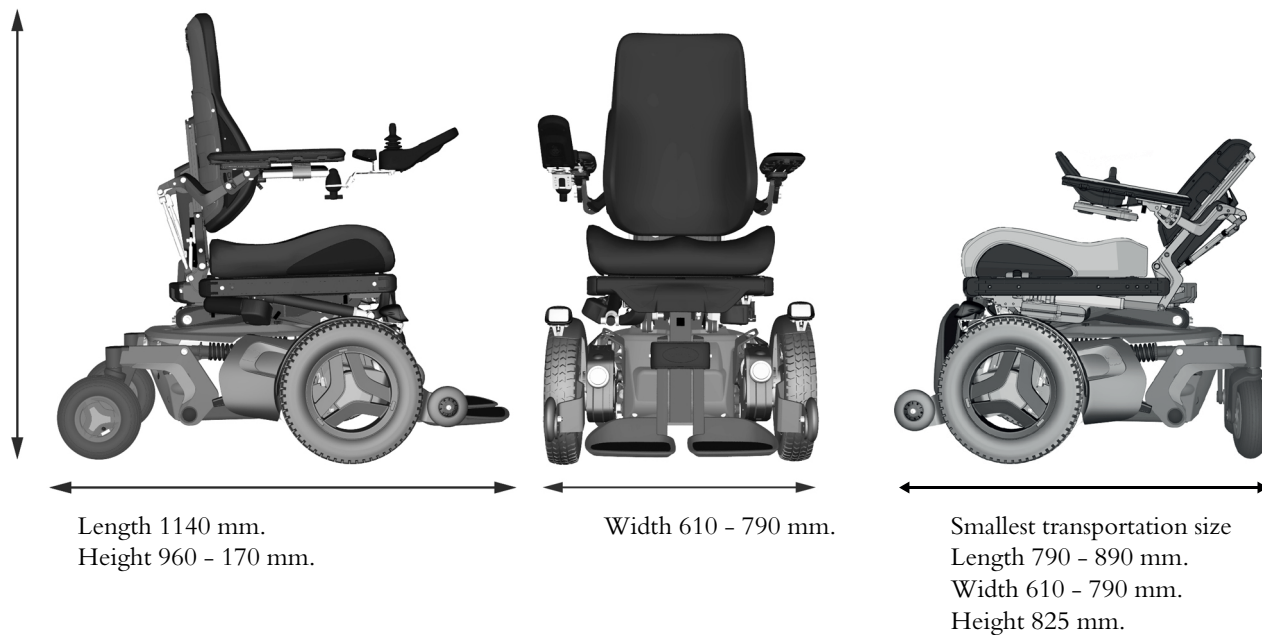
Figure 1. F3 Corpus overview

The F3 Corpus is a powered front-wheel drive wheelchair for outdoor and indoor driving. It is intended for people with physical disabilities.

The wheelchair consists of a chassis and a seat. The chassis contains the wheelchair's electronics, power supply and drive functions. The seat consists of a seat frame, seat plate, backrest, armrest, leg support, seat lift or fixed seat pole and any accessories or options such as a headrest, calf rest, etc.

3.2 Technical specifications

Product name	F3 Corpus
Wheelchair class	B



3.2.1 Dimensions and weight

Length	1140 mm
Width	610 - 790 mm

Height		960 – 1170 mm
Weight, including batteries		175 kg/184 kg
Minimum transport length	790 – 890 mm	
Minimum transport height	825 mm	
Minimum transport width	610 – 790 mm	
Seat plane angle		0°
Effective seat depth		370 – 570 mm (in 25 mm increments)
Effective seat width		420 – 570 mm (in 50 mm increments)
Seat surface height at front edge (with powered seat lift)		mm
Seat surface height at front edge (with fixed seat pole)		mm (one time adjustment)
Seat tilt angle		(powered)
Backrest angle		135° (manual backrest) 150° & 180° (powered backrest)
Backrest height		470 – 670 mm (in 25 mm increments)
Backrest width		360 – 510 mm (in 50 mm increments)
Footplate to seat distance		265–430 / 145–270 mm
Leg support to seat surface angle		90° – 180° (manual and powered)
Armrest to seat distance		185 – 320 mm
Distance between armrests		380 – 480/480 – 580 mm
Front location of armrest structure		0 – 435 mm
Horizontal displacement of axle		20 mm

3.2.2 Performance

Range	25 – 30 km
Maximum speed forward	10 km/h
Minimum braking distance from max. speed	2,8 m
Hill-climbing ability	12°
Safe slope	6°
Static stability downhill	13°
Static stability uphill	17°
Static stability sideways	14°
Ability to negotiate obstacles (approach distance 0 cm)	60 mm
Ability to negotiate obstacles (approach distance 50 cm)	75 mm
Minimum ground clearance with user weight	76 mm
Maximum user weight	150 kg
Minimum turning diameter	1350 mm
Pivot width	1040 mm

3.2.3 Wheels

Drive wheel tyre dimensions	3.00" x 8"
Castor wheel tyre dimensions	210 x 65 mm
Recommended tyre pressure	200 – 250 kPa (2 – 2.5 bar)

3.2.4 Electronics

R-net drive electronics type	PM120
------------------------------	-------

3.2.5 Batteries

Recommended battery type	24 cells, gel
Battery capacity	2 x 60 Ah or 2 x 73 Ah, maintenance-free
Charging time	8 hours
Weight (2 x 60 Ah)	2 x 19 kg
Weight (2 x 73 Ah)	2 x 23 kg

3.2.6 Control force

Joystick	1.5 N
Keys	2 N

3.2.7 Circuit breakers

Main circuit breaker	63 A
----------------------	------

3.2.8 Power adjustable leg length

Maximum length from footplate to seat plate	520 mm
Minimum length from footplate to seat plate	300 mm
Maximum load	70 kg

3.3 Design and function

3.3.1 Seat

3.3.1.1 Powered seat functions

The powered seat functions are driven by an electric actuator which is steplessly controlled from the control panel of the wheelchair. The movement can be interrupted in any position and fixed there.

Available functions may vary depending on how the seat is equipped.

Available functions may vary depending on the equipment fitted on your wheelchair.

- seat lift
- seat tilt
- backrest recline
- anterior tilt
- leg support
- powered adjustable leg length

**WARNING!****Risk of pinching while using seat functions**

There is a risk of crush-point accidents when using the powered seat functions. Make absolutely sure that nothing gets stuck between moving parts. Failure to do so may lead to personal injury.

Powered seat lift

A power-controlled seat lift allows stepless raising or lowering of the seat in order to adjust the height to tables, benches etc.

When the seat lift is raised from the lowest position, the maximum speed of the wheelchair may be reduced.



WARNING!

Tipping risk – driving with seat functions in use

When operating the seat functions, the centre of gravity is also shifted, increasing the risk of tipping over. Only use the seat functions on a level floor.

Always drive at the lowest speed and never tilt the seat or back so far that the wheelchair cannot be manoeuvred safely.

Powered seat tilt

i Applies to wheelchairs equipped with powered seat tilt.



Figure 2. Powered seat lift.

The powered seat tilt control allows the preferred seat angle to be set within the operating range.



WARNING!

Tipping risk – driving with seat functions in use

When operating the seat functions, the centre of gravity is also shifted, increasing the risk of tipping over. Only use the seat functions on a level floor.

Always drive at the lowest speed and never tilt the seat or back so far that the wheelchair cannot be manoeuvred safely.



Figure 3. Powered seat tilt.

Anterior tilt

i The following section only applies to wheelchairs equipped with anterior tilt.

The anterior tilt function is only available on wheelchairs equipped with a powered seat lift and seat tilt.

The anterior tilt function has programmable positions to meet individual needs. Typical tilt positions are: 10°, 20° and 30° — 45°.

- 10° makes it easier to reach objects, for instance on a table.
- 20° extends your reach further.
- 30° — 45° makes it easier to transfer into and out of the seat; the footrests are lowered to floor level in these positions.

When the seat is being tilted forwards or backwards, it will stop when it reaches a pre-programmed position or a neutral, not tilted, position. In order to continue the movement forwards or backwards from a position, press the button or repeat the joystick manoeuvre again. The tilt angle may vary depending on how the anterior tilt is programmed and if any positioning limitations apply.

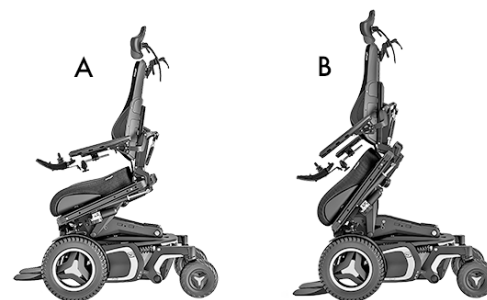


Figure 4. Anterior tilt.

**WARNING!****Anterior tilt**

Improper use of the anterior tilt feature on the wheelchair could cause the user to fall forward causing injury. Only use anterior tilt when recommended by a licensed clinical professional and/or ATP. Always use all positioning components on the wheelchair such as lap belts, chest straps, and knee blocks. They are installed to meet the user's specific safety needs.

**WARNING!****Risk of pinching while using seat functions**

There is a risk of crush-point accidents when using the powered seat functions. Make absolutely sure that nothing gets stuck between moving parts. Failure to do so may lead to personal injury.

Powered backrest angle

The backrest angle is adjustable (via the recline control), allowing the user to set a recline angle as needed within the operating range.



WARNING!

Risk of pinching while using seat functions

There is a risk of crush-point accidents when using the powered seat functions. Make absolutely sure that nothing gets stuck between moving parts. Failure to do so may lead to personal injury.



Figure 5. Powered backrest angle.

Powered leg support angle

The leg supports can be raised to the preferred angle within the operating range.



Figure 6. Powered leg supports.

Powered adjustable leg length

Powered adjustable leg support permits steplessly variable adjustment of the height of the footplate (leg support length). In this way, the pressure on the back of the thighs is easily adjusted.

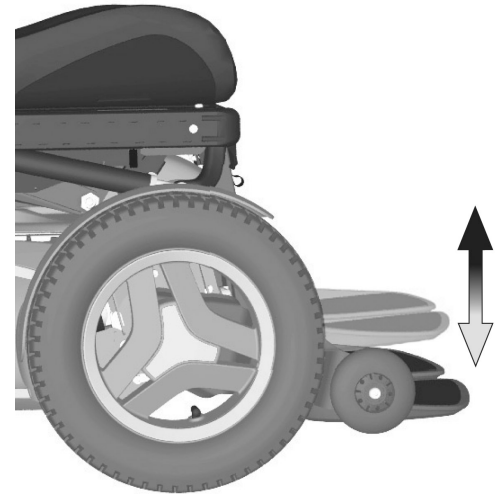


Figure 7. Power adjustable leg length.

3.3.1.2 Manual seat functions

The seat is manually adjustable by adjusting the locking tubes with quick-acting locks to a number of fixed positions. Available functions may vary depending on the equipment fitted on your wheelchair.



Figure 8. Manual clamping pole for the backrest recline.

Backrest recline

The angle of the backrest is adjusted via an adjustable locking pole with a quick-acting lock in a number of fixed positions. From an upright position, the backrest can be inclined max. 45° backwards.

1. Pull out the quick-acting lock's spring action handle so that the locking pole moves freely and the backrest can be angled.
2. Adjust the backrest angle to the required angle.
3. Lock the locking pole securely by releasing the handle so that it engages in the intended hole in the locking pole.
4. Check that the backrest is locked in position.



WARNING!

Risk of crushing while adjusting backrest angle

Do not put weight on the backrest while adjusting the angle. There is a risk of crush-point accidents.



Figure 9. Manually adjusting backrest angle.

Leg support angle

The angle of the leg support is adjusted via an adjustable locking pole with a quick-acting lock. The leg support is adjustable from the vertical position all the way up to the horizontal position and can be locked in a number of fixed positions in between.

1. Pull out the quick-acting lock's spring-action handle so that the locking pole moves freely and the leg support can be angled.
2. Adjust the leg support angle to the required angle and then lock the locking pole securely by releasing the handle so that it engages with the intended hole in the locking pole.
3. Check that the leg support is locked in position.



WARNING!

Risk of crushing while adjusting leg support angle

Do not put weight on the leg support while adjusting the angle. There is a risk of crush-point accidents.



Figure 10. Manually adjusting leg support angle.

3.3.1.3 Other Adjustment Options

The control panel, armrest, footplates and other accessories such as calf rest, thigh support, trunk support, headrest, etc. have manual adjustment and setting options.

3.3.2 Chassis

3.3.2.1 Drive unit and shock absorbers

The wheelchair is equipped with a drive unit (B) and a shock absorber (C) for each drive wheel. The link arms are also equipped with shock absorbers (A).



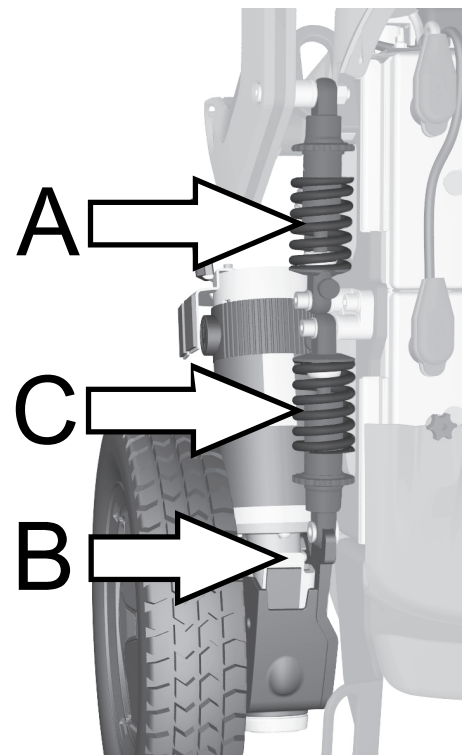
NOTICE

Shock absorber adjustments should be performed by personnel who are well-acquainted with the design and functionality of the wheelchair. When adjustment is needed, contact an authorised Permobil service centre.

The drive unit consists of an electric motor with a gearbox and magnetic wheel lock.

3.3.2.2 Wheels

The wheelchair's drive wheels are available with pneumatic tyres or flat-free (foam-filled) tyres. The castor wheels are available with solid polyurethane tyres or pneumatic tyres.



3.3.2.3 Lights and reflectors

The wheelchair is equipped with reflectors at the front, rear and sides.

Front lights, rear lights and indicators are optional.



Figure 12. Front reflectors.

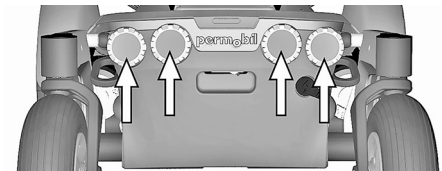


Figure 13. Back reflectors.

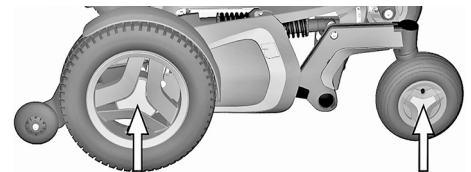


Figure 14. Side reflectors.

3.3.2.4 Batteries

The wheelchair's batteries are located under the covers of the chassis. Both batteries are easily accessible for maintenance and replacement.



WARNING!

Handling batteries - avoid short-circuit

Exercise caution when using metallic objects during work with batteries. A short-circuit can easily cause an explosion. Always use safety gloves and goggles.

Remember that the batteries are heavy and must be handled with great caution.



CAUTION!

Recycling batteries

Used or malfunctioning batteries must be disposed of responsibly in accordance with local recycling regulations.

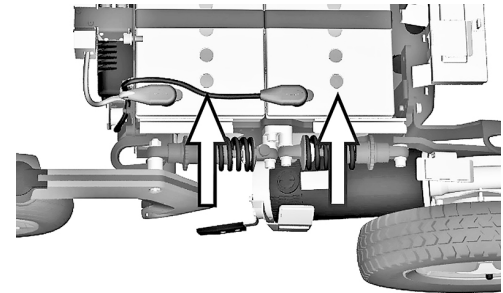


Figure 15. Location of batteries.

3.3.2.5 Main circuit breaker

The F3 Corpus is equipped with an automatic main circuit breaker, which can be reset when it has been triggered. It also functions as a battery isolator and is controlled (ON/OFF) via the lever located in front of the left battery cover.



NOTICE

Investigate tripped main circuit breaker

A tripped main circuit breaker often indicates a major electrical fault. The cause of a tripped main circuit breaker must be carefully investigated and determined before resetting the circuit breaker.



Figure 16. Main circuit breaker.

3.3.2.6 Charging socket

The charging socket is located at the rear of the chassis. The socket is covered with a protective cover; open it to access the socket.



CAUTION!

Switch off main circuit breaker

Always switch off the power supply to the control panel before interrupting the power with the main circuit breaker.

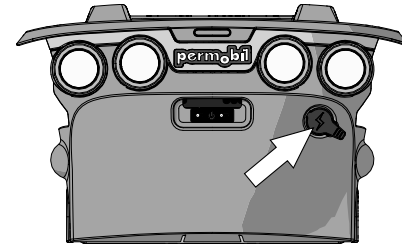


Figure 17. Charging socket

3.4 Control panel

3.4.1 R-net LCD control panel

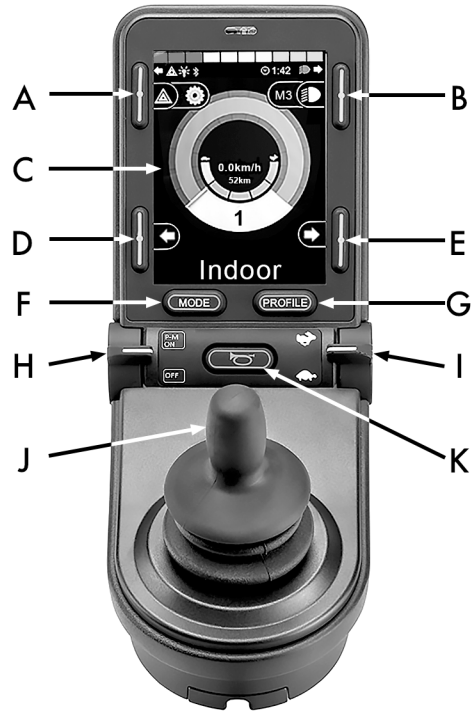


Figure 18. Control panel overview.

- A.** Hazard flashers on or off.
- B.** Headlights on and off.
- C.** Screen.
- D.** Left indicators.
- E.** Right indicators.
- F.** Mode button.
- G.** Profile button.
- H.** Main power On or Off; mode or profile selector.
- I.** Maximum speed paddle, decrease or increase.
- J.** Joystick.
- K.** Horn button.

The overview image on the preceding page shows the basic functions of the control panel. All buttons, toggle switches and the joystick may have additional functionality.

The charging socket is located on the front of the panel

Figure 19 *Charger socket*

Two jack sockets are located on the base of the panel. One is intended for an external on/off switch and the other for an external profile switch. Figure 30 *Jack sockets*

The wheelchair may also be equipped with an extra seat control panel in addition to the control panel.

3.4.1.1 Charger socket

This socket may only be used for charging or locking the wheelchair. Do not connect any type of programming cable to this socket. Do not use the socket as a power supply for any other electrical device. Connecting other electrical devices may damage the control system or affect the wheelchair's EMC (electromagnetic compatibility) performance.



NOTICE

Use only the supplied battery charger

The wheelchair's guarantee will be rendered invalid if any device other than the battery charger supplied with the wheelchair or the lock key is connected via the control panel charger socket.

3.4.1.2 Buttons and paddle switches

On the control panel, there are a total of 7 buttons and 2 paddle switches.

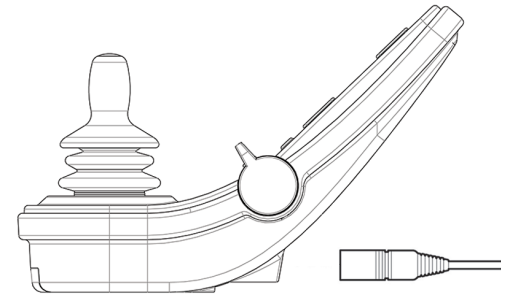


Figure 19. Charger socket

Power, mode and profile paddle

The paddle switch is used to switch the control system on or off.

Push the paddle forward to switch the power on and pull it backwards to switch the power off.

The paddle switch can also be used to scroll through the available profiles and modes. Push the paddle forward to scroll through the available profiles and modes.

i If your panel is equipped with an early version of the toggle switch as shown in figure 21, follow the description below.

Pull on the paddle switch to switch the power on or off.

The paddle switch can also be used to scroll through the available profiles and modes. Push the paddle forward to scroll through the available profiles and modes.



Figure 20. Power, mode and profile paddle.

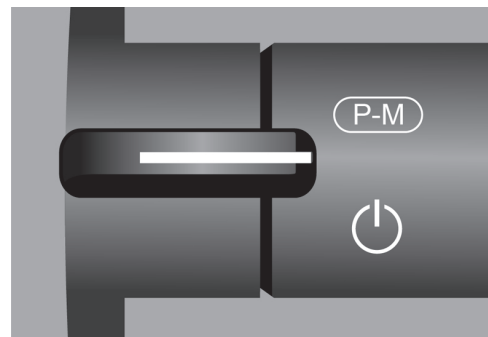


Figure 21. Power, mode and profile paddle switch, early version.

Maximum speed paddle

This paddle decreases or increases the wheelchair's maximum speed. The maximum speed indicator on the display shows the current setting. Push the paddle forward to increase the setting and backwards to decrease the setting.

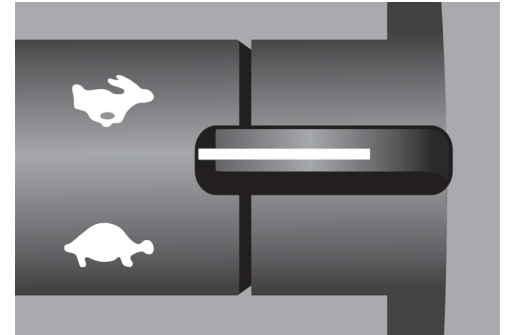


Figure 22. Maximum speed paddle, decrease or increase.

Horn button

The horn will sound while this button is depressed.



Figure 23. Horn button.

Mode button

The mode button allows the user to navigate through the available operating modes for the control system. The available modes depend on programming and the range of auxiliary output devices connected to the control system.



Figure 24. Mode button.

Profile button

The profile button allows the user to navigate through the profiles available for the control system. The number of profiles available depends on how the control system is programmed.

Function buttons

There are a total of four buttons located on the left and right sides of the display. The symbols on the display show the current button function.

Hazard warning button and screen symbol

i Only active if the wheelchair is fitted with lights.

This button switches the wheelchair hazard lights on or off. The hazard lights are used when the wheelchair is positioned in such a way that it constitutes an obstruction for others. Push the button to switch the hazard lights on and push it again to switch them off. When activated, the screen symbol will flash in sync with the wheelchair hazard lights.



Figure 25. Profile button.



Figure 26. Hazard warning button and screen symbol.

Lights button and screen symbol

i Only active if the wheelchair is fitted with lights.

This button switches the wheelchair lights on or off. Push the button to switch the lights on and push it again to switch them off. When on, the lights screen symbol lights up.



Figure 27. Lights button and screen symbol.

Left turn indicator button and screen symbol

i Only active if the wheelchair is fitted with lights.

This button switches the wheelchair's left turn indicator on or off. Push the button to switch the indicator on and push it again to switch it off. When activated, the left indicator screen symbol will flash in sync with the wheelchair's indicator.



Figure 28. Left turn indicator button and screen symbol.

Right indicator button and screen symbol

i Only active if the wheelchair is fitted with lights.

This button switches the wheelchair's right indicator on or off. Push the button to switch the indicator on and push it again to switch it off. When activated, the right indicator screen symbol will flash in sync with the wheelchair's indicator.



Figure 29. Right indicator button and screen symbol.

3.4.1.3 Jack sockets

The external On/Off switch jack (A) allows the user to turn the control system on or off using an external device such as a buddy button.

The external profile switch jack (B) allows the user to select profiles using an external device, such as a buddy button. To change the profile while driving, simply press the button.

3.4.1.4 Display

The status of the control system can be understood by observing the display. The control system is on when the display is backlit.

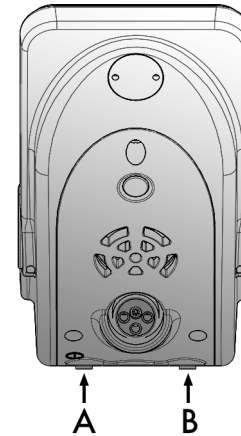


Figure 30. Jack sockets

Screen symbols

The R-net drive screen has common components that always appear and components that only appear under certain conditions.

- A.** Speedometer
- B.** Profile name
- C.** Battery indicator
- D.** Clock
- E.** Maximum speed indicator
- F.** Current profile

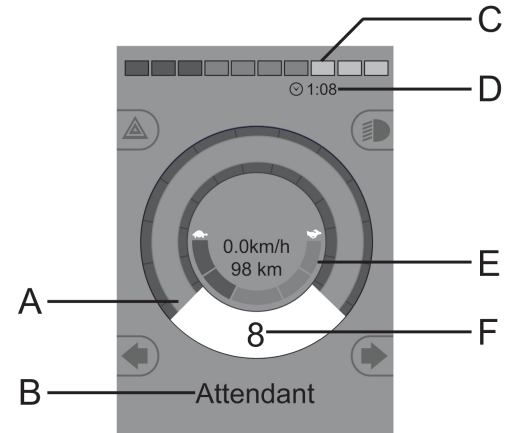


Figure 31. Drive screen when set to profile 8.

Battery indicator

This displays available battery charge and can be used to alert the user of the status of the battery.

- **Steady light:** everything is in order.
- **Flashing slowly:** the control system is functioning correctly, but charge the battery as soon as possible.
- **Stepping up:** the wheelchair batteries are being charged. The wheelchair cannot be driven until the charger is disconnected and the control system is switched off and on again.

Maximum speed indicator

This displays the current maximum speed setting.

The maximum speed setting is adjusted using the speed paddle.



Figure 32. Battery indicator.



Figure 33. Maximum speed indicator.

Current profile

The profile number describes which profile the control system is currently operating in. The profile text is the name or description of the profile the control system is currently operating in.



Figure 34. Current profile.

In focus

When the control system contains more than one method of direct control such as a secondary joystick module or a dual attendant module, the module that has control of the wheelchair displays the 'in focus' symbol.



Figure 35. In focus.

Speed limited

If the speed of the wheelchair is being limited; e.g., by a raised seat, then this symbol will be displayed. If the wheelchair is being inhibited from driving, then the symbol will flash.



Figure 36. Speed limited.

Restart

When the control system requires a restart, e.g. after a module reconfiguration, this symbol will flash.



Figure 37. Restart required.

Control system temperature

This symbol is displayed when the control system has intentionally reduced its own power to protect itself against heat damage.

Motor temperature

This symbol is displayed when the control system has intentionally reduced the power to the motors to protect them against overheating.

Hourglass

This symbol is displayed when the control system is changing states. An example would be entering into programming mode. The symbol is animated to show sand falling.

Emergency stop

If the control system is programmed for latched drive or actuator operation, then an emergency stop switch is usually connected to the external profile switch jack. If the emergency stop switch is operated or disconnected, this symbol will flash.



Figure 38. Temperature control of system.



Figure 39. Motor temperature.



Figure 40. Hourglass.



Figure 41. Emergency stop.

Settings Menu

The Settings Menu permits the user to set the clock, display brightness, background colour etc.

Press the hazard flasher button for 2 seconds in order to open the menu. Scroll through the menu by moving the joystick back and forth.

A right joystick deflection will enter a submenu with the related function options.

Exit the setting menu by first selecting Exit on the bottom of the menu and then moving the joystick to the right.

The menu items are described in the following sections.

Time

The following section describes submenus related to Time.

- | | |
|---------------------|--|
| Set Time | allows the user to set the current time. |
| Display Time | this sets the format of the time display or turns it off. The options are 12 hr, 24 hr or Off. |

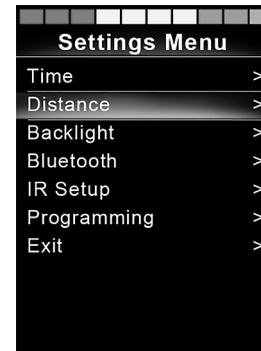


Figure 42. Settings Menu.

Distance

The following section describes submenus related to Distance.

- Total Distance** this value is stored in the power module. It is related to the total distance driven during the time that the current power module has been installed in the chassis.
- Trip Distance** this value is stored in the joystick module; it relates to the total distance driven since the last reset.
- Display Distance** sets whether Total Distance or Trip Distance appears as the odometer display on the joystick module.
- Clear Trip Distance** a right joystick deflection will clear the Trip Distance value.

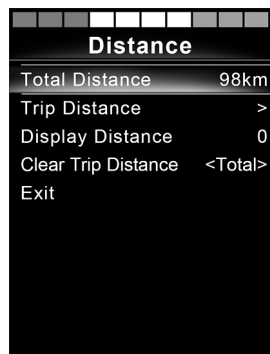


Figure 43. Distance measurement.

Backlight

The following section describes submenus related to Backlight.

- Backlight** this sets the backlight on the screen. It can be set between 0% and 100%.
- Auto Backlight** the joystick module contains an ambient light sensor to automatically adjust screen brightness. The programmable options are Off or On. Set to On the display adjusts the screen brightness based on the light sensor reading. Set to Off ; screen brightness will not change with changes in light intensity.
- Backlight Time** this adjusts the period of time the backlight will remain active once no further instructions are received from an input device. It is adjustable between 0 and 240 seconds.

Bluetooth®

i Applies to control panels equipped with integrated Bluetooth®.

A right deflection of the joystick will enter a sub-menu to configure the Bluetooth® mode screen. Refer to the Bluetooth® mode chapter for more details, see page 80.

IR Setup

i Applies to control panels equipped with integrated IR.

A right deflection of the joystick will enter a sub-menu for learning and deleting IR codes. Refer to the IR section for more details; see page 93.

Programming

The following section describes submenus related to Programming.

Sleep	sets the time after which the control system will go to sleep if an input device command is not received.
Sounder Volume	sets the volume of the sounder used to indicate button presses.
Horn Volume	sets the volume of the horn.
Start-up Beep	sets whether or not the controller emits a short beep when turned on. Available only in later versions of the control panel.
Momentary Screens	sets whether programmed Momentary Screens are displayed.
Display Speed	sets how the wheelchair's speed is displayed; options are mph, km/h or Off.
Displays	sets the format of the digital drive display; options are odometer, speed or both.

Diagnostics allows the user to read diagnostic information from the control system.

Diagnostics		Diagnostics	
PM 2.5	>	Center Joystick	4
Gyro 2.3	>	Bad Cable	7
ISM 1.94	>	M2 Brake Error	1
JSM 1.0	>	Low Battery	1

Figure 44. Two samples from the Diagnostic screen.

Timers enables the user to view how many hours the chair has been driven for.

Exit

Exits the Settings Menu.

3.4.1.5 Bluetooth® mode

i Applicable only to R-net control panels, 3,5" or 2,8" colour display, with Bluetooth® integrated in the joystick module.

The joystick modules differ in that the 3,5" screen version is equipped with the buttons *Mode* and *Profile*, positioned under the screen. Joystick modules with 2,8" screens are more compact and lack these buttons.

General

When a wheelchair is delivered equipped with a control panel containing Bluetooth®, the Bluetooth® functions are pre-programmed to a basic setup. This setup is described below.

The basic setup is prepared for pairing of up to four Bluetooth® devices, two PC mice or Android™ devices and two iDevices®, without any additional tools. The setup can be reprogrammed using a programming key and an R-net programmer installed on a computer. With this equipment, it is possible to e.g. rename or replace text and icons describing a certain device, activate mouse commands, nudge time, change the cursor speed etc.

Pairing with devices

A device must be set to On from the Settings Menu before it can be paired. Follow the description below.

Settings Menu

Press the hazard flasher button for 2 seconds in order to open the Settings Menu. Select Bluetooth®.

The screen now displays the submenu as illustrated.

Choose a device; set it to On with a right deflection by the joystick.

The R-net system must now be switched off and then on again.

The name of each device can be changed by using a computer with an installed R-net programming tool.

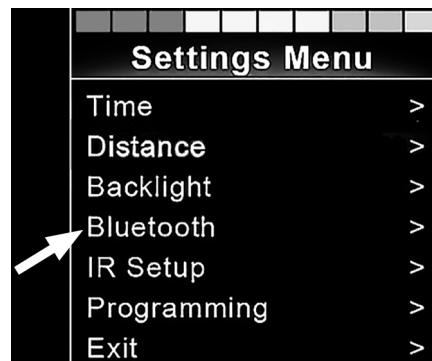


Figure 45. Select Bluetooth® to get access to the submenu.

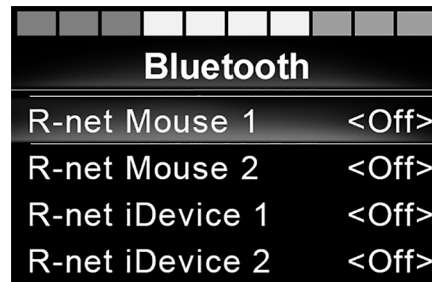


Figure 46. The Bluetooth® sub-menu.

Pairing setup

The control panel Bluetooth® must then be put into Discovery Mode by following this sequence description:

- Deflect the joystick in a forward direction and hold until there is a beep. This takes approximately 10 seconds; then release.
- Deflect the joystick in the reverse direction and hold until there is a beep. This takes approximately 10 seconds; then release.

The screen will display a flashing Bluetooth® icon above the computer image. This confirms that the control panel Bluetooth® is set in Discovery Mode. It is now discoverable for other Bluetooth® devices.

Pairing with different devices

Depending on the type of device you are pairing with; a PC, an Android™ device or an iDevice®, you will need to follow a specific procedure depending on the device you want to connect to.

Some procedures are described below.



Figure 47. The arrow points to the flashing Bluetooth® icon.

Pairing with a PC

The following process should be carried out on a PC:

- Open the window where you can select a Bluetooth® device to add to the PC. The name and path will differ slightly for different versions of Windows.
- Enter the password 1234 if prompted.
- Click on R-net Mouse X when it appears on the screen and the connection will be finalised. The R-net mouse will now appear in the list of devices on the PC.
- When an connection is established, the Bluetooth® icon on the control panel display stops flashing.

Pairing with an Android™ device

The following process should be carried out on the Android™ device

- Select system settings and set Bluetooth® to On.
- Select R-net Mouse X from the list of available devices.
- Enter the password 1234 if prompted.
- R-net Mouse X should now appear as a paired device.
- When an connection is established, the Bluetooth® icon on the control panel display stops flashing.

Pairing with iDevice®

The following process should be carried out on the iDevice®.

- Select settings and set Bluetooth® to On.
- Select R-net iDevice® X from the list of available devices.
- R-net iDevice® X should appear as a paired device.
- When a connection is established, the Bluetooth® icon on the control panel display stops flashing.

Updating the list of devices

The control panel stores the Bluetooth® IDs of up to four devices.

To replace an entry on the list of devices, one of the existing pairings must be deleted. This process is initiated from the paired device and will vary depending on the type of device.

Once a device is unpaired, a new device can be added.

Operating Bluetooth® devices

This section describes the basic settings of a wheelchair delivered with a control panel with integrated Bluetooth®.

Accessing a Bluetooth® device

The following section describes how to access one of the paired Bluetooth® devices.

To enter Bluetooth® mode

i Joystick module with 2,8" screen is more compact and lacks Mode and Profile buttons.

Press button Mode (A) a number of times until Bluetooth® mode is entered or press and hold key B for more than 2 seconds to enter Bluetooth® mode, M3.



Figure 48. Two ways to access a Bluetooth® device.

If more than one Bluetooth® device is paired and enabled, a screen will appear where a Bluetooth® device can be selected for connection and use.

If only one Bluetooth® device is enabled, it will be shown directly on the screen.

Step between the devices by deflecting the joystick forward or back.

Select the device by right deflection.

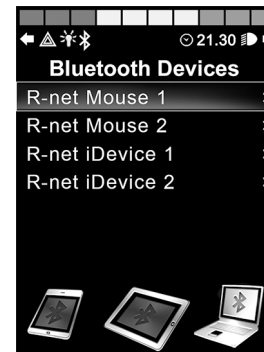


Figure 49. The Bluetooth® Device screen from which paired devices are chosen.

When a Bluetooth® device is selected, the screen will show an icon representing the chosen device type.

If only one Bluetooth® device is enabled, this screen will appear as soon as Bluetooth® mode is activated.

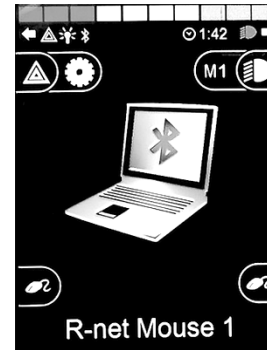
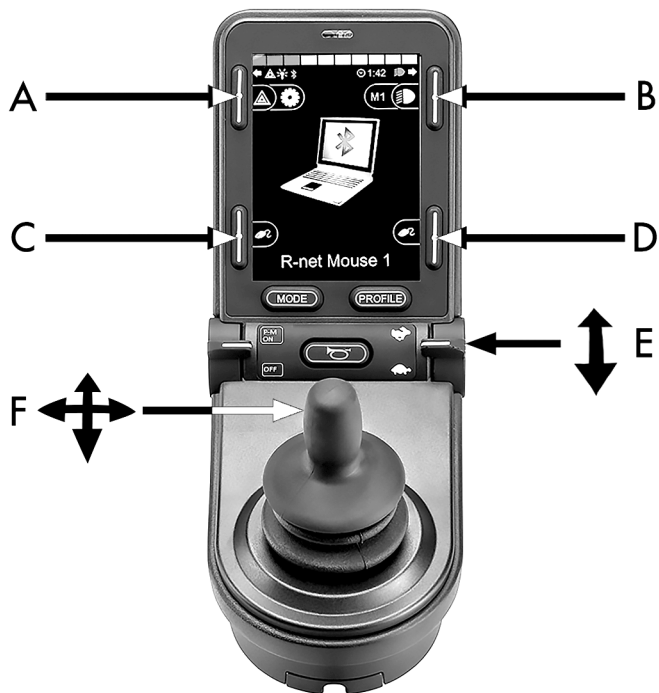


Figure 50. A selected Bluetooth® device.

Operating buttons in Bluetooth® mode



- A. Access settings, page 89.
- B. Return to drive mode, page 89.
- C. Left mouse click, page 90.
- D. Right mouse click, page 90.
- E. Scroll up or down, page 90.
- F. Joystick functions, page 91.

Figure 51 . Buttons and other controllers for operating in Bluetooth® mode.

Buttons A to D, paddle switch E and joystick F, as shown in the previous overview illustration, have predefined functions when a Bluetooth® device is selected in Bluetooth® mode. The functions are described below.

A – accessing settings

Press the button for more than 2 seconds. This opens the Setting Menu (Setting Menu); see *Settings Menu*, Page 75.

A short press turns the hazard flashers on or off.



Figure 52. Button to access settings in Bluetooth® mode.

B – return to drive mode

Press the button for more than 2 seconds. This puts the wheelchair into drive mode.

A short press turns headlights on or off.



Figure 53. Button to return to drive mode from Bluetooth® mode.

C – left mouse click

Press button to perform a left mouse click.



Figure 54. Left button for left mouse clicks.

D – right mouse click

Press button to perform a right mouse click.



Figure 55. Right button for right mouse clicks.

E – scroll up or down

Push the paddle switch to scroll up.

Pull the paddle switch to scroll down.



Figure 56. In mode Bluetooth® the right paddle switch is used to scroll up or down.

F – joystick functions

Move cursor in desired direction by deflecting the joystick.

Nudge forward to scroll up.

Nudge back to scroll down.

Left mouse click; left nudge.

Right mouse click; right nudge.

- i** A nudge is a quick, full deflection; settings can be changed to accommodate your needs using a computer with the programming tool installed.



Figure 57. With the use of Bluetooth® the joystick can take control of the mouse functions.

Notes - Bluetooth® mode settings changed after delivery

Button, toggle switch or joystick	Function

3.4.1.6 IR mode

- i** Applicable only for R-net control panels with integrated IR, 3.5" or 2.8" colour display with IR.

General

The infrared control, integrated in the joystick module, makes it possible to replicate commonly used IR devices, such as remote controls for TV, audio, cable, satellite or environmental controls. IR codes can either be learned without any tools or loaded by the PC-based IR configurator software. The programming abilities of the IR configurator entail more than just loading codes.

This manual describes only the learning method.

The wheelchair is prepared for IR mode but there are no IR codes stored in the system at delivery.

IR setup

IR Setup menu can be accessed via the Settings Menu; see *Settings Menu, Page 75*.

On entering the IR Setup menu, the default appliances will appear. When an appliance is selected, its commands are shown.

When a command is followed by a tick, it means that it has a stored IR code. When a command is not ticked, its IR code has not yet been stored.

IR codes can be stored or deleted as described in the following sections.



Figure 58. The IR Setup screen.

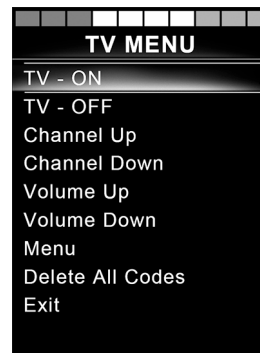


Figure 59. Commands on the TV MENU screen.

Learning an IR code

The IR receiver is located above the screen on the control panel, marked with an A in the figure.

When learning a code, the remote control device must be held so that its IR transmitter points towards the IR receiver on the control panel, i.e. the little window marked A in the figure.

Learning an IR code procedure

Enter the IR Setup menu.

Select an appliance, e.g. TV – (Device 1) as illustrated. "(Device 1)" shows where the equipment's unique name may appear on the screen.



Figure 60. The IR receiver location.

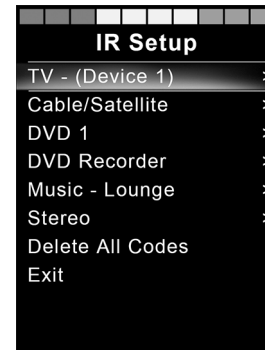


Figure 61. Sample of IR Setup.

The commands for the appliance will appear on the screen as shown in the figure. Select a command to learn.

In this example, Channel Up will be selected from the TV MENU.

Select Learn Code, by deflecting the joystick right while the command is highlighted.

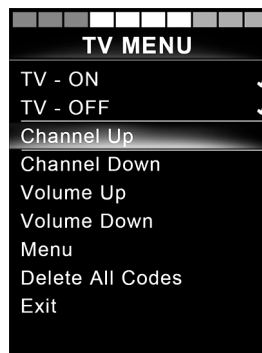


Figure 62. The screen displayed when an appliance has been selected.

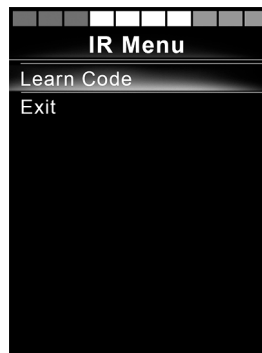


Figure 63. IR Setup menu, Learn Code.

Point the TV remote control towards the control panel's IR receiver and press the channel up button twice.



Figure 64. Point the remote control at the IR receiver. Press the button twice.

If the Learn Code operation has been successfully completed, a green tick will be displayed on the screen.



Figure 65. Learning operation successful.

If the Read Code operation fails, a red cross will be displayed on the screen. Please retry the Learn Code operation.

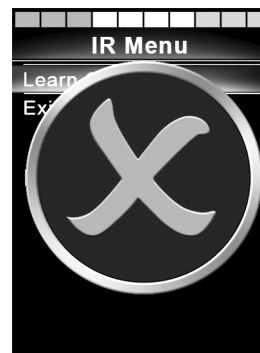


Figure 66. Learning operation unsuccessful.

After the code has been learned, scroll down to highlight Exit. Deflect the joystick to the left to return to the appliance menu, IR Setup.

- i** The first time an IR code is learned, it is necessary to cycle the power by turning the power off at the control panel and then on again. If other IR codes have already been learned, it is not necessary to cycle the power.

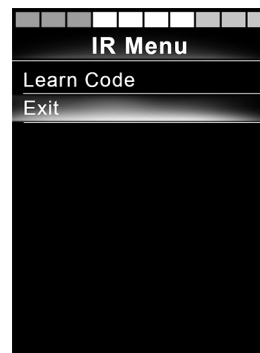


Figure 67. Scroll down to Exit.

Learning sequenced IR codes

Multiple IR codes can be learned for a single command in the IR Setup menu. This enables multiple IR codes to be transmitted through a single command when in IR mode.

Examples:

1. The on/off function for multiple appliances, the TV and the DVD for example, can be learned by a single entry in the IR Setup menu. The control panel will then transmit the codes for the learned command in one burst. In this case, the TV set and the DVD recorder will be turned on or off practically simultaneously.
2. Previously, selecting a TV channel required the user to select the individual channel's digits from a list. This could be quite inconvenient when trying to select a TV channel with multiple digits e.g. Channel 143. Now the individual codes for the numbers 1, 4 and 3 can be learned by a single command in the IR Setup menu. When this command is selected in IR Setup menu, the IR codes are transmitted practically simultaneously.

Create a sequence

- Select the command to use as the sequence initiator. In this example, TV – ON.
- Select Learn Code, by deflecting the joystick to the right while the command is highlighted.
- Point the TV remote control at the control panel's IR receiver and press the On/Off button twice.
- After each successful learning operation, a tick momentarily appears on the screen. Select Learn Code again.
- Point the DVD remote control at the control panel's IR receiver and press the On/Off button twice.
- After each successfully learned operation, a tick momentarily appears on the screen. Select Learn Code again.
- Complete the sequence by highlighting Exit and deflecting the joystick to the left.
- Now the TV – ON command will have a tick and three dots beside it, showing a learned sequence.



Figure 68. A tick followed by three dots showing a learned sequence.

Enabling and disabling IR codes

IR codes can be enabled or disabled in the IR Setup menu. If a code is disabled, it will not transmit and will not appear in IR mode.

To disable an IR code, deflect the speed paddle up or down. A disabled IR code appears with an X against the highlighted command.

To enable an IR code, deflect the speed paddle up or down. An enabled code appears with a tick against the highlighted command.

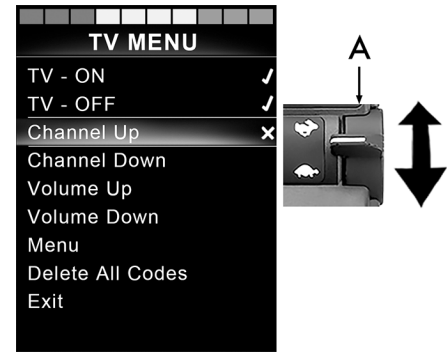


Figure 69. Screen and speed paddle switch marked A.

Deleting IR codes

To delete an IR code for a specific command, highlight the command in the appliance menu and deflect the joystick to the right. Then select the Delete Code option.

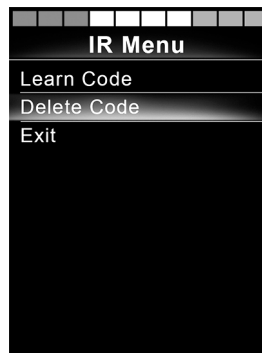


Figure 70. Deleting codes for specific commands.

To delete all IR codes for an appliance, select Delete All Codes within that appliance's sub-menu.

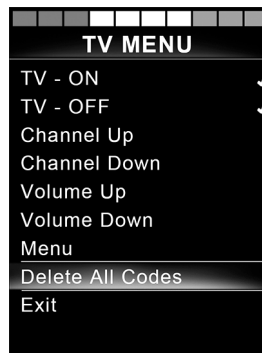


Figure 71 . Deleting all codes for a specific appliance.

To delete all IR codes stored in the control panel, select Delete All Codes within the IR Setup menu.



Figure 72. Delete all codes from the IR Setup menu.

3.4.1.7 Locking and unlocking the control system

Locking

- Switch the control system on and move the paddle forward.
- After 1 second, the control system will beep. Now release the paddle.
- Deflect the joystick forward until the control system beeps.
- Deflect the joystick backward until the control system beeps.
- Release the joystick; there will be a long beep.
- The wheelchair is now locked.
- The wheelchair is switched off.



Figure 73. The lock symbol is displayed when the wheelchair is locked.

Unlocking

- If the control system has switched off, move the paddle forward.
- Deflect the joystick forward until the control system beeps.
- Deflect the joystick backward until the control system beeps.
- Release the joystick; there will be a long beep.
- The wheelchair is now unlocked.

3.4.1.8 Seat functions

Not applicable to all seat models

On some seats, the powered functions can be controlled using the control panel joystick. Some models can memorise three seat positions. The seat adjustment mechanism stores each memorised seat position. This makes it easy to retrieve a seat position saved earlier.

Manoeuvring the seat

1. Press the Mode button once or more times until a seat function icon appears in the control panel display.
2. Move the joystick to the left or right to select a seat function. The icon for the seat function selected appears in the display. The icons shown vary depending on the seat model and available functions.
3. Move the joystick forward or backward to activate the function.



NOTICE

The symbol M

If the symbol M appears together with the seat icon, it means the memory function has been activated. Move the joystick to the left or right to choose a seat function instead.

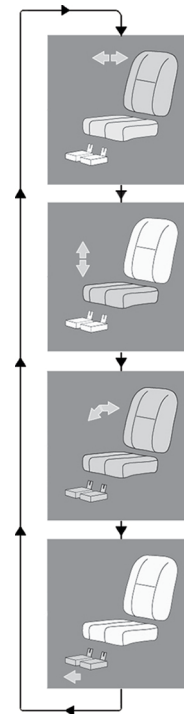


Figure 74. Manoeuvring the seat, examples of icons that may appear.

Return to drive mode

Press the Mode button one or more times until a standard display image with a speed indicator appears in the control panel display.



Figure 75. Standard display image with speed indicator.

Memory

Retrieving position from memory

Some seat control systems can memorise three seat positions. The seat adjustment mechanism stores each memorised seat position. This makes it easy to retrieve a seat position saved earlier.

1. Press the Mode button once or more times until a seat function icon appears in the control panel display.
2. Move the joystick to the left or right to select a memorised position (M1, M2 or M3). A seat icon and memory symbol M for the memorised position selected are shown in the control panel display.
3. Move and hold the joystick forwards. The seat adjusts to the position stored earlier. For reasons of safety, the joystick must be held forward until the seat is fully adjusted to the required position. Once the seat has assumed the saved position, it will stop moving.

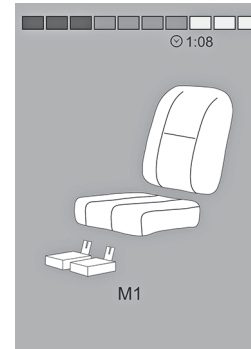


Figure 76. Memory function activated.



NOTICE

Releasing the joystick stops seat movement

Release the joystick at any time to stop seat movement.

Return to drive mode

Press the Mode button one or more times until a standard display image with a speed indicator appears in the control panel display.

Saving a seat position to memory

1. Set the seat's powered functions to the preferred position.
2. Activate the seat memory function by pressing the Mode button once or more times until a seat icon appears in the control panel display.
3. Move the joystick to the left or right to select a memorised position (M1, M2 or M3). A seat icon and memory symbol M for the memorised position selected are shown in the control panel display.
4. Move the joystick backward to activate the Save function. An arrow will appear next to the memory symbol M.
5. Save the current position by moving the joystick forward and holding it in that position until the arrow next to the memory symbol M disappears.

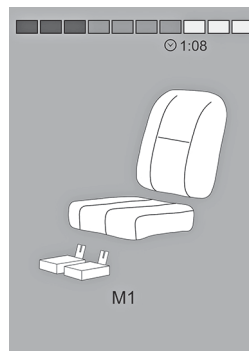


Figure 77. Memory function activated.

Return to drive mode

Press the Mode button one or more times until a standard display image with a speed indicator appears in the control panel display.

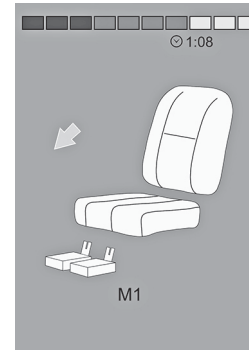


Figure 78. Save function activated.

3.4.2 Joystick panel, R-net LED control panel

3.4.2.1 General

The control panel consists of a joystick and function buttons. At the front of the panel is the charging socket.

The wheelchair may also be equipped with a seat control panel in addition to the control panel.



Figure 79. Control panel.

3.4.2.2 Charger socket

This socket may only be used for charging or locking the wheelchair. Do not connect any type of programming cable to this socket. Do not use the socket as a power supply for any other electrical device. Connecting other electrical devices may damage the control system or affect the wheelchair's EMC (electromagnetic compatibility) performance.



NOTICE

Use only the supplied battery charger

The wheelchair's guarantee will be rendered invalid if any device other than the battery charger supplied with the wheelchair or the lock key is connected via the control panel charger socket.

3.4.2.3 Function buttons

The control panel has a total of 9 function buttons and a joystick.

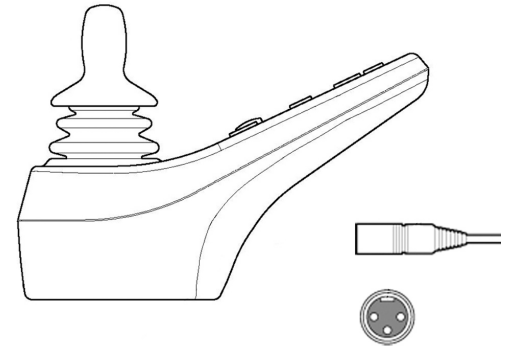


Figure 80. Charger socket

On/Off button

The On/Off button switches on power to the control system electronics, which in turn supply power to the wheelchair's motors.

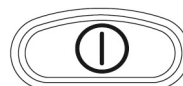


Figure 81. On/Off button.

Horn button

The horn will sound while this button is depressed.



Figure 82. Horn button.

Button and LED for adjusting speed or setting driving profile

This button usually reduces or increases the wheelchair's maximum speed. Alternatively, the button can be used to set the driving profile.

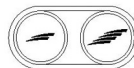


Figure 83. Button and LED for maximum speed or setting the driving profile.

Mode button

These buttons normally reduce or increase the wheelchair's maximum speed. Alternatively, the button can be used to set the driving profile.



Figure 84. Mode button.

Hazard warning button

i Only available if the wheelchair is fitted with lights.

This button switches the wheelchair hazard lights on or off. The hazards lights are used when the wheelchair constitutes an obstruction for others. Push the button to switch the hazard lights on and push it again to switch them off. When activated, the hazard LED will flash in sync with the wheelchair's hazard lights.

Lights button

i Only available if the wheelchair is fitted with lights.

This button switches the wheelchair lights on or off. Push the button to switch the lights on and push it again to switch them off. When on, the lights LED lights up.

Left indicator button

i Only available if the wheelchair is fitted with lights.

This button switches the wheelchair's left indicator on or off. Push the button to switch the indicator on and push it again to switch it off. When activated, the left indicator LED will flash in sync with the wheelchair's indicator.



Figure 85. Hazard warning button and LED.



Figure 86. Lights button and LED.



Figure 87. Left indicator button and LED.

Right indicator button

i Only available if the wheelchair is fitted with lights.

This button switches the wheelchair's right indicator on or off. Push the button to switch the indicator on and push it again to switch it off. When activated, the right indicator LED will flash in sync with the wheelchair's indicator.

3.4.2.4 Battery voltage indicator

The battery voltage indicator does not show exactly how much charge is left in the battery, but it provides a rough idea to help you avoid unnecessary stops due to discharged batteries.

The indicator shows a more precise value about 1 minute after you stop driving and are no longer using any powered functions.



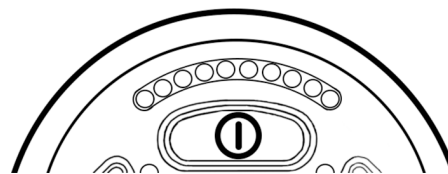
NOTICE

Voltage indicator also used as fault indicator

The battery voltage indicator also functions as a fault indicator for the wheelchair's electronics. See page 283 for further information.



Figure 88. Right indicator button and LED.



The display shows battery status (from left to right):

Red, Yellow and Green	Fully charged
Red and Yellow	Semi-charged
Red	Charge the batteries

Figure 89. Battery voltage indicator.

3.4.2.5 Maximum speed indicator

Speed

Indicates the maximum speed set for the wheelchair.

Driving profile

For special applications, the wheelchair can be programmed with more than one driving profile. In this case, the indicator LEDs will instead display the selected driving profile. There can be up to 5 driving profiles.



NOTICE

Speed indicator also used as a fault indicator

The maximum speed or driving profile indicator also functions as a fault indicator for the wheelchair's electronics. See page 283 for further information.

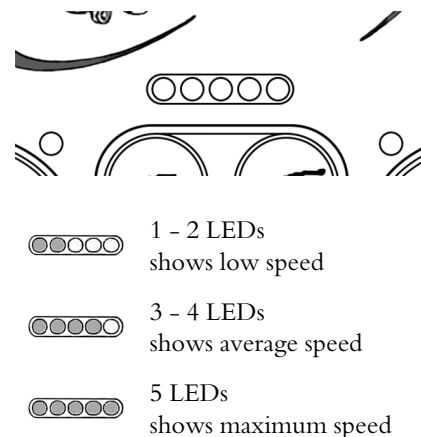


Figure 90. Maximum speed indicator.

3.4.2.6 Seat indicator

On certain seats, the powered seat lift, seat angle, backrest angle and leg support angle functions are controlled by the control panel joystick. In this case, the active seat function is shown on the control panel seat indicator.

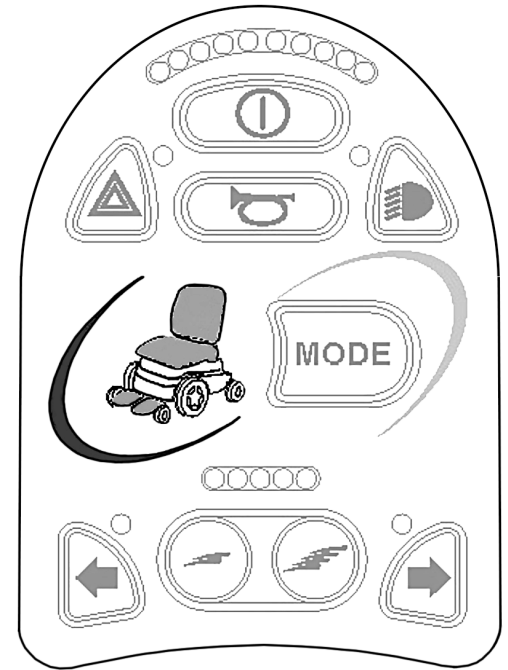


Figure 91 . Seat indicator.

3.4.3 ICS seat control panel

3.4.3.1 General

The seat's powered functions may be controlled from the drive system control panel. On seats equipped with the control system ICS, the powered functions may also be controlled from the ICS control panel.

The seat's powered functions are controlled from the control panel. The control system may be in the form of push buttons or toggle switches for those users who find them easier to manoeuvre. Move the toggle switch forward to operate the front button and backward to operate the rear button. The button box functions described here apply to conventional push buttons, but the functions are the same regardless of control system design.

Each switch location can have two functions, and the symbol for the active function is lit up. Change functions with the shift function.



The number of available functions will vary depending on how the wheelchair and seat are equipped.



Figure 92. ICS seat control panels, the topmost equipped with push buttons and the lower with paddle switches.

Feedback

The control panel provides feedback regarding the available seat functions, active seat function inhibits, active drive speed limits and active drive inhibits through its LEDs.

The LED above the switch can assume three states:

1. Off

The function icon is extinguished or off. This means the function is not currently active. Toggle selection of the left or right seat functions with the Shift Switch

2. Steady LED

A steady LED provides the user with information concerning drive speed.

- A steady green LED means the chair can be driven at full speed.
- A steady yellow LED signifies that the drive speed is limited due to the position of this actuator.
- A steady red LED means the drive is inhibited due to the position of this actuator.

3. Flashing LED

A flashing LED provides the user with actuator-related information.

- A flashing green LED signifies a special or extended feature.

- A flashing yellow LED means the seat function is inhibited in one direction, due to a safety limit. The switches below the icon will only move the seat in the safe direction.
- A flashing red LED means an actuator error has been detected. Depending on the type of error, the switches below may or may not operate the seat function. Note the circumstances when this indication occurs as this information may help your service provider. Contact your service provider for additional assistance, as service may be necessary.

3.4.3.2 Functions



WARNING!

Risk of pinching while using seat functions

There is a risk of crush-point accidents when using the powered seat functions. Make absolutely sure that nothing gets stuck between moving parts. Failure to do so may lead to personal injury.

Seat lift

The seat can be raised by pressing the upper part of the button and lowered by pressing the lower part.

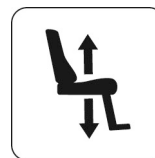


Figure 93. Seat lift.

Backrest recline

The backrest can be reclined by pressing the lower part of the button and brought back by pressing the upper part.

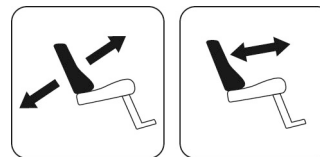


Figure 94. Backrest recline.

Seat tilt

The seat can be tilted backward by pressing the lower part of the button and forward by pressing the upper part.

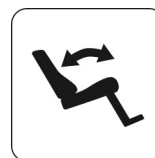


Figure 95. Seat tilt.

Anterior tilt

The seat can be tilted forward by pressing the upper part of the button and backward by pressing the lower part. When the seat is being tilted forward or backward, the seat will stop when it reaches neutral position. To keep moving forward or backward from neutral position, press the same button again.

Leg support angle

The leg support can be tilted forward by pressing the upper part of the button and backwards by pressing the lower part.

Power adjustable leg length

The footplate can be raised by pressing the upper part of the button and lowered by pressing the lower part.

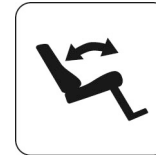


Figure 96. Anterior tilt.

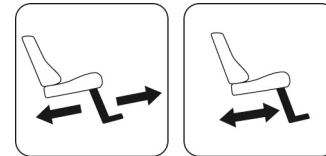


Figure 97. Leg support angle.

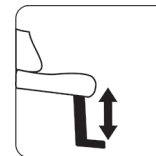


Figure 98. Power adjustable leg length.

Seat-to-floor function

The seat can be lowered to the floor by pressing the upper part of the button, and raised by pressing the lower part.



Figure 99. Seat to floor function.

Power footplates

The footplates can be raised by pressing the lower part of the button and lowered by pressing the upper part.

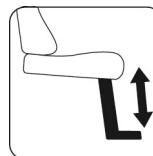


Figure 100. Power footplates.

Power transfer footplate

The footplate can be lowered at the same time as the seat lift is raised by pressing the upper part of the button. Pressing the lower part of the button will raise the footplate and at the same time lower the seat lift. This function can help the user get in and out of the wheelchair.

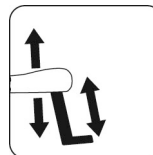


Figure 101. Power transfer footplate.

Shift

Change the control button functions by pressing the Shift button. Change the function back again by pressing the Shift button. The symbol for the active function will light up.

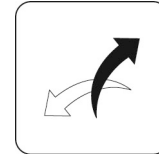


Figure 102. Shift.

Memory function

ICS control panels equipped with memory can store and recall up to three seat positions. A seat function (e.g. power tilt, power recline, power legs, etc.) can only memorise a position if it has an actuator with position feedback installed.

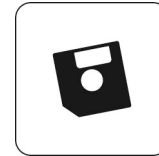


Figure 103. Memory function.

Return to a preset position

1. Enter memory mode by pressing and holding the memory button (8) for two seconds. While in memory mode, the memory LED flashes green.
2. Press and hold the appropriate Recall button (1, 2 or 3) to move the seating system to the preferred preset position. As a safety feature, releasing a Recall button stops actuator movement. When the stored position is reached, the actuator movement stops, the LED above the memory position lights up green and the control panel beeps.
3. Return to standard seat function operating mode by pressing the Memory button (8).



Figure 104. Memory function.

Storing memory

Before storing a seating position in the memory, configure the seat system in the desired position.

1. Enter memory mode by pressing and holding the memory button (8) for two seconds. While in the memory mode, the LED flashes green.
2. Press and hold button (4) until the LED immediately to the left of the Memory LED lights up green. Memory is now enabled and ready to memorise a seat position.
3. Press and hold the desired Store button (5, 6 or 7) for three seconds to memorise the current seat position. The LED above the memory position will light up red and the control panel will beep once the memory is successfully stored.
4. Return to standard seat function operating mode by pressing the Memory button (8).



Figure 105. Memory function.

3.5 Accessories

Accessories for Permobil products are subject to continuous development. Contact your nearest Permobil dealer for more information on the accessories available for your product.

3.5.1 ConnectMe

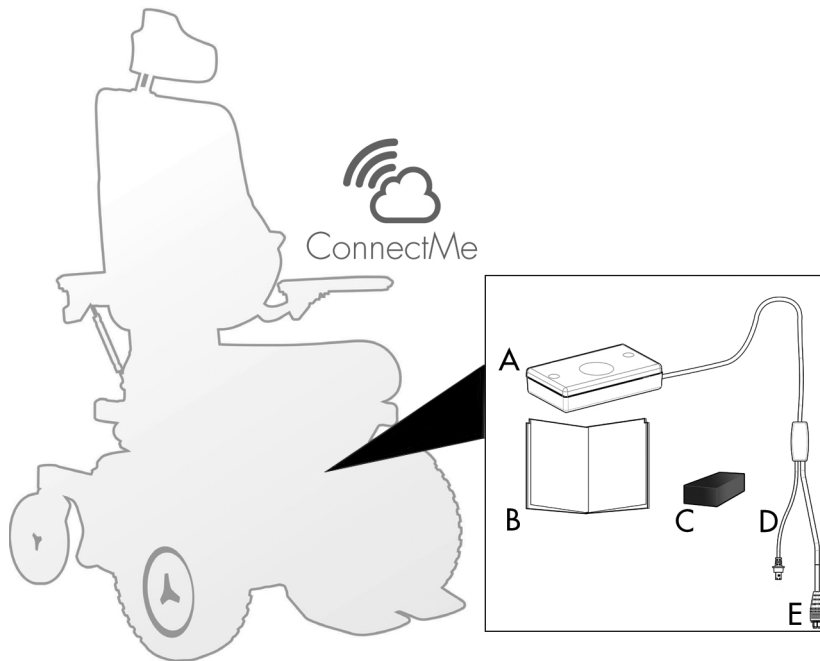


Figure 106. Overview ConnectMe kit.

- A.** Housing with push button.
- B.** Manual
- C.** EPDM rubber for installation.
- D.** Cable with ICS connector.
- E.** Cable with R-net connector.

ConnectMe is a cellular solution that provides communication between the Permobil wheelchair and Permobil cloud service. It is also used in near field communication for transfer of data between the wheelchair and a Bluetooth® device (e.g. smartphone).

3.5.1.1 Federal Communications Commission (FCC) Statement

This equipment has been tested and found to comply with the limits for a Class B digital device, pursuant to part 15 of the FCC Rules. These limits are designed to provide reasonable protection against harmful interference in a residential installation. This equipment generates, uses and can radiate radio frequency energy and, if not installed and used in accordance with the instructions, may cause harmful interference to radio communications. However, there is no guarantee that interference will not occur in a particular installation. If this equipment does cause harmful interference to radio or television reception, which can be determined by turning the equipment off and on, the user is encouraged to try to correct the interference by one or more of the following measures:

- Reorient or relocate the receiving antenna.
- Increase the distance between the equipment and receiver.
- Connect the equipment into an outlet on a circuit different from that to which the receiver is connected.

- Consult the dealer or an experienced radio/TV technician for help.

FCC Caution: Any changes or modifications not expressly approved by the party responsible for compliance would void the user's authority to operate this equipment.

This device complies with part 15 of the FCC Rules. Operation is subject to the following two conditions:

1. This device may not cause harmful interference.
2. This device must accept any interference received, including interference that may cause undesired operation.

3.5.1.2 Radiation Exposure Statement

This equipment complies with FCC radiation exposure limits set forth for an uncontrolled environment. End users must follow the specific operating instructions for satisfying RF exposure compliance.

To maintain compliance with FCC RF exposure compliance requirements, please follow operation instructions as documented in this guide. This transmitter must not be co-located or operated in conjunction with any other antenna or transmitter, except the transmitter built-in with this device.

3.5.1.3 Prepare for use

In order to make sure that no damage has occurred to ConnectMe while it was being shipped, please check the following before use:

- All products ordered are included in the delivery, including manuals and other documentation. If something is missing, please contact your dealer or Permobil for further information.
- No transport or other related damage has occurred to the product. If something has been damaged or appears to be incorrect, please contact your dealer or Permobil for further information as soon as possible.
- If ConnectMe is not behaving normally, disconnect the power from your wheelchair and contact your dealer or Permobil immediately.

**CAUTION!****Correct installation**

- ConnectMe must be installed by an authorised service technician. If the product is incorrectly installed, it may cause damage to the product, wheelchair, or other property as well as bodily harm to the user.
- ConnectMe must be installed more than 20 cm from the user.
- ConnectMe is solely made for Permobil powered wheelchairs. Mounting ConnectMe to equipment other than a Permobil powered wheelchair is prohibited. If a user fails to follow this warning, Permobil takes no responsibility for the resulting damage.

**WARNING!****Modifications**

Any unauthorised modifications to ConnectMe or its various systems may increase the risk of personal injury and property damage, including damage to the wheelchair. Do not modify the ConnectMe device. Modifications to ConnectMe may cause damage to the device, the wheelchair, other property and/or bodily damage. Any adjustment to ConnectMe must be performed by an authorised service technician.

**NOTICE****Storage**

When ConnectMe is not attached to a Permobil wheelchair, store the product in a secure location to prohibit unauthorised access.



NOTICE

System data

ConnectMe can record systems data and, if activated, can transmit some data in certain instances, including GPS location. This information helps, for example, to diagnose wheelchair systems and to continuously improve wheelchair safety. Permobil may access the information and share it with others:

- with the consent of the wheelchair owner or his or her personal representative;
- for safety research or wheelchair diagnosis purpose;
- in response to an official request by law enforcement or other government agency;
- for use in dispute resolution involving Permobil, its affiliates or sales / service organisation; and
- as otherwise required or permitted by law.

For additional information about how Permobil may use your data, please refer to the privacy notice at <http://www.permobil.com/en/Corporate/Company/Company/Permobil-Privacy-Policy/>

**WARNING!****Flight mode**

The ConnectMe device contains a radio transmitter. In certain areas radio transmission is not allowed and ConnectMe has to be set to flight mode, see 3.5.1.8 *Flight mode*. Examples of these types of areas include, but are not limited to:

- Areas with a potentially explosive atmosphere such as fuelling areas, below decks on boats, fuel or chemical transfer or storage facilities, areas where the air contains chemicals or particles, such as grain, dust, or metal powders.
- Areas where radio silence is requested such as hospitals, clinics or healthcare facilities in order to prevent possible interference with sensitive medical equipment.
- Airports or inside aircraft when you are instructed by airport or airline staff to use flight mode.
- Blasting areas or in areas posted with notifications requesting “two-way radios” or “electronic devices” to be turned off to avoid interfering with blasting operations.

The user is responsible for paying attention to where radio transmission is allowed and also where it is not allowed.

3.5.1.4 Technical specifications

Radio network

GSM:	Quad-band 850 / 900 / 1800 / 1900 MHz
UMTS:	RF Band: B1, B2, B5, B8
Network antenna:	Internal
Connectivity:	Bluetooth 4.1
Connectivity antenna:	Internal

Positioning

GNSS:	A-GPS L1, GLONASS, Galileo
GNSS antenna:	Internal

Dimensions and weight

Dimensions (Length x Width x Height):	85 x 48 x 19 mm (excluding cable)
Cable length:	1 m

Dimensions and weight

External connectors:	6-pin MODU, 4-pin RNET
Weight:	60 gram, 145 gram (including cable)

Rating

Power Operation:	Operational: 24 VDC, $I_{max} = 430\text{mA}$, $I_{avg} = 60\text{mA}$ Standby: 24 VDC, Max 0.5 mA
Main fuse:	1 m
Ambient temperature:	Storage: -40°C to $+65^{\circ}\text{C}$ Operating: -25°C to $+50^{\circ}\text{C}$

3.5.1.5 Product approval

ConnectMe fulfils the requirements of the following standards:		
	EN 12184 EN 14971 EN 60601-1 + A1 EN 301 489-1 v1.9.2 EN 301 489-7 v1.3.1 EN 301 489-17 v2.2.1 EN 301 489-24 v1.5.1 EN 301 511 v12.1.1	EN 301 908-2 v7.1.1 EN 300 328 V1.9.1 EN 62311 ISO 7176-9 ISO 7176-14 ISO 7176-21 ETSI TS 134 124 v10.0.0
FCC	FCC 47 CFR Part 15 B FCC 47 CFR Part 15 C (15.247) CFR47 1.1310 2.109 KDB 447498 D01 v06	
	ConnectMe FCC ID: Device contains FCC ID:	2AKPO331495 N7NWP8
IC	ConnectMe IC ID: Device contains IC:	22277-331495 2417C-WP8
Industry Canada	RSS-GEN, Issue 4 RSS-247, Issue 1 RSS 102, Issue 5	

3.5.1.6 Market approval

Certifications	
AT and T	Certified for use in AT and T global network
PTCRB:	Certified according to PTCRB in North America
Bluetooth:	Declared bluetooth smart product

Supported wheelchairs	
Chassis:	M3 M5 F3 F5 M300 M400
This list is subject to change as ConnectMe support for wheelchairs will evolve. Contact your dealer or Permobil for further information about the current list of supported wheelchairs.	

ConnectMe complies with Industry Canada's licence-exempt RSSs. Operation is subject to the following two conditions:

1. This device may not cause interference; and
2. This device must accept any interference, including interference that may cause undesired operation of the device.

3.5.1.7 Serial number label

Label explanations: Numbers in parenthesis refer to QR code GS1 Application Identifiers	
Prod. Date (yyymmdd):	Date of manufacturing
S/N:	Serial number
Item no:	Permobil internal item number with revision
HVIN:	Hardware Version Identification Number
ICC ID:	Integrated Circuit Card Identifier
Supplier ID:	Permobil assigned manufacturer ID
IC:	Industry Canada assigned ID
FCC ID:	FCC assigned ID
This device contains: IC: 2417C-WP8 / FCC ID: N7NWP8:	This is the FCC/IC ID of the pre-qualified embedded GSM/UMTS module.
Permobil AB:	Manufacturer address
Permobil Inc.:	Alternative manufacturer address

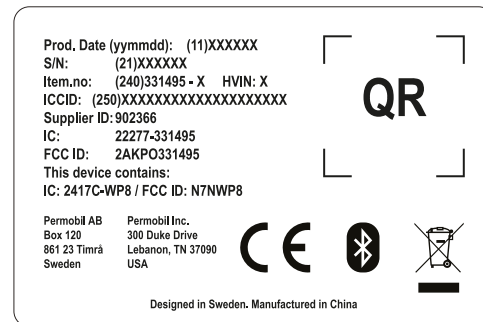


Figure 107. The serial number label of Connect/Me is located on the rear side of the enclosure.

3.5.1.8 Flight mode

The ConnectMe device contains a radio transmitter. In certain areas radio transmission is not allowed and ConnectMe has to be set to flight mode,

Turn OFF radio transmission; activate Flight mode

1. Make sure the main switch is in the “On” position. Please see section in your wheelchair manual. Go into seat mode by using ”Mode” button on the joystick.

i Permobil Joystick module with 2.8” screen is more compact and lacks Mode and Profile buttons. Use left paddle switch for mode selection.



Figure 108. “Mode” button.

2. Scroll through seat menus until menu M6 is shown.



Figure 109. M6 menu.

3. Hold the joystick knob forward for 5 seconds.



Figure 110. Time to hold the knob forward.

4. A warning message will be shown in the display indicating “Flight Mode On”. This means that the transmitting modem on ConnectMe is off.

The warning message will continue to show in the display as long as Flight mode is active. However, the wheelchair will function as normal.



Figure 111. “Flight mode on”.

Turn ON radio transmission; deactivate Flight mode

1. Make sure the main switch is in the “On” position. Please see section in your wheelchair manual. Go into seat mode by using ”Mode” button on the joystick.

i Permobil Joystick module with 2.8” screen is more compact and lacks Mode and Profile buttons. Use left paddle switch for mode selection.



Figure 112. “Mode” button.

2. Scroll through seat menus until menu M6 is shown.



Figure 113. M6 menu.

3. Hold the joystick knob forward for 5 seconds.



Figure 114. Time to hold the knob forward.

4. The warning message "Flight Mode On" will disappear. ConnectMe is now fully operational again.



Figure 115. "Flight mode on" inactivated.

3.5.1.9 Turn off ConnectMe completely

ConnectMe device is powered as long as the battery in the wheelchair is connected to its electronics. In order to completely turn off the ConnectMe device, the main fuse has to be set in its "Off" state.

3.5.1.10 General usage

When mounted on wheelchair, ConnectMe requires no maintenance or operation by the user

All interaction with ConnectMe is either done through the cloud service web interface or from a companion Bluetooth device.

Cleaning

You can clean the ConnectMe device with a soft cloth/sponge if necessary.

Storage

Do not store ConnectMe in rooms susceptible to mist, dampness or water, such as pool areas, laundry rooms or similar rooms. If you have questions about the proper storage of the ConnectMe, contact your supplier or Permobil.

Maintenance and Service

Only perform the minor adjustments and maintenance as specified in the user manual. All other service, repairs and maintenance must be performed by an authorised service technician.

3.6 Labels

Take a good look at all the labels on the wheelchair and get acquainted with their meaning. The labels contain important information for safe and proper use.

**WARNING!**

Accident risk – Always replace missing labels

Never remove a label from the wheelchair. If a label becomes difficult to read or falls off, order a replacement label from Permobil.

3.6.1 Read the instructions

The label indicates that there are instructions that must be read and understood before use or adjustment.

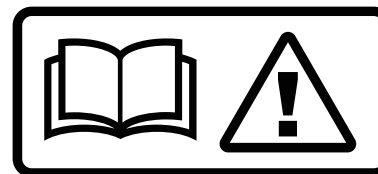


Figure 116. Read the instructions.

3.6.2 Main circuit breaker also battery isolator

The label shows switch positions for power supply Off or On.

A description of main circuit breaker function is found on page 265.



Figure 117. Main circuit breaker also battery isolator.

3.6.3 Wheel locks

The label shows the wheel lock release lever positions in released and activated states.

A description of wheel lock function is found on page 266.

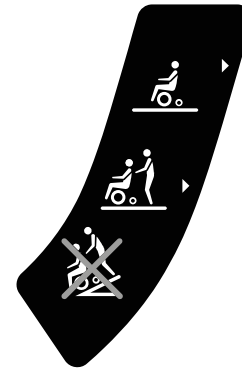


Figure 118. Wheel locks.

3.6.4 Tie-down point

The label indicates where the wheelchair must be secured during transportation. There is a label next to each tie-down point.

A description of wheel lock function is found on page 206.



Figure 119. Tie-down point.

3.6.5 Support wheels

The label indicates that the wheelchair is fitted with support wheels to reduce the risk of tipping when driving over obstacles, etc. They must always be fitted when you drive.



Figure 120. The support wheels must always be fitted when you drive.

3.6.6 Crush hazard

The label indicates a crush hazard.



Figure 121. Crush hazard.

3.6.7 Warning

The label indicates that special attention is required.

Exercise extreme caution where this warning symbol appears.
Failure to observe warnings may lead to personal injury, including damage to the wheelchair and other property.



Figure 122. Warning, special attention is required.

3.6.8 Battery connections and main circuit breaker

The labels show the polarity which differs depending on which battery capacity, 60 Ah or 73 Ah, the product is equipped with.

The positive battery cable (+) is shown in red on the label.

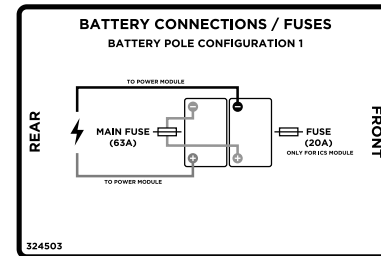


Figure 123. Battery terminals, main circuit breaker and fuse, apply to products equipped with 60 Ah batteries.

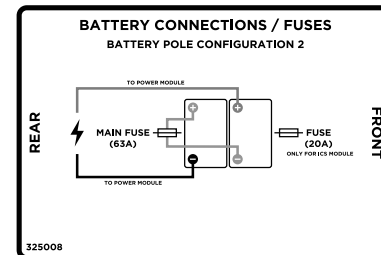


Figure 124. Battery terminals, main circuit breaker and fuse, apply to products equipped with 73 Ah batteries.

3.6.9 Serial number label

1. Made in (country of final assembly) by (address of site of final assembly).
2. Serial number.
3. Product type.
4. Date of assembly.
5. EAN code.
6. Maximum user weight.

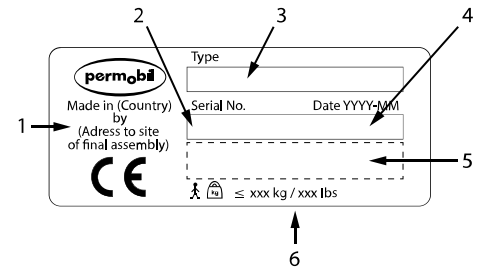


Figure 125. Serial number label.

4 Preparing for use

4.1	Settings and adjustments	155
4.1.1	Headrest	155
4.1.2	Permobil headrest with link hardware	157
4.1.3	Backrest	161
4.1.4	Armrest	164
4.1.5	Leg support	170
4.1.6	Footplates	173
4.1.7	Knee support	175
4.1.8	Panel holder	178
4.1.9	Positioning belt	183
4.2	Handling and driving	184
4.2.1	General - driving	185
4.2.2	Manual brake release	187
4.2.3	Support wheels	190
4.2.4	Driving technique	191
4.2.5	Driving restrictions	193
4.2.6	Joystick error	200
4.3	Batteries	201
4.3.1	Charging the batteries	202
4.4	Transporting the wheelchair	206
4.4.1	Vehicle transportation	206

4.4.2	Air transportation	215
4.4.3	Rail transportation	216

4.1 Settings and adjustments

4.1.1 Headrest

 Accessory

This headrest has expanded adjustment options to give the user optimal comfort. The headrest can also be removed and remounted while preserving the same setting.



Figure 126. Headrest overview

4.1.1.1 Removing headrest

1. Undo the handle (C) on the rear of the backrest.
2. Remove the headrest by lifting it straight up.

4.1.1.2 Mounting headrest

Mount in the reverse order

4.1.1.3 Adjusting headrest height and depth

1. Undo the handle (A) on the rear of the backrest.
2. Adjust the height/depth of the headrest as required.
3. Tighten the handle (A).

4.1.1.4 Adjusting headrest angle

1. Undo the handle (B) on the rear of the headrest.
2. Adjust the angle of the headrest as required.
3. Tighten the handle (B).

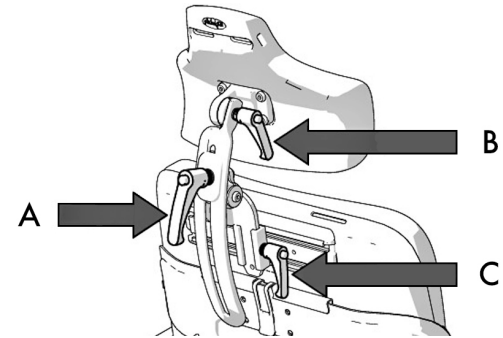


Figure 127. Adjusting headrest



NOTICE

Risk of damaging mechanism

Do not put weight on the headrest while adjusting it.

4.1.2 Permobil headrest with link hardware

Accessory

This headrest has expanded adjustment options to give the user optimal comfort. It is easy to find a correct fit for anyone and the headrest may be removed and installed while preserving the same settings.

4.1.2.1 Removing the headrest

1. Undo the handle (B) at the back of the backrest.
2. Remove the headrest by lifting it straight up (A).

4.1.2.2 Installing the headrest

1. Install in the reverse order.

Figure 128. Removal of headrest.

4.1.2.3 Headrest height

1. Undo the handle (B) at the back of the backrest.
2. Remove the headrest by lifting it straight up (A).
3. Adjust the height by changing the placement of the screw on the inside of the bracket. Place the screw in one of the four positions depending on the preferred height. Position 1 provides the lowest setting and position 4 provides the highest setting.

i If position 1 is to be used, all the functions of the chair must be tested using that position to check for interference.

4. Install in the reverse order.

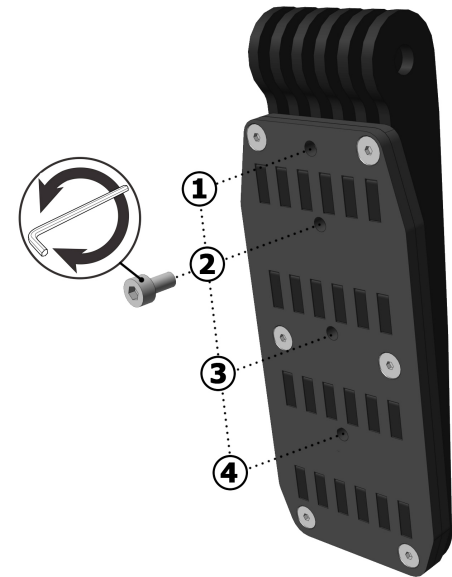


Figure 129. Height adjustment screw.

4.1.2.4 Headrest height and depth

1. Undo the screws located at each link.
2. Adjust the height and depth by angling the links as required.
3. Tighten the screws.

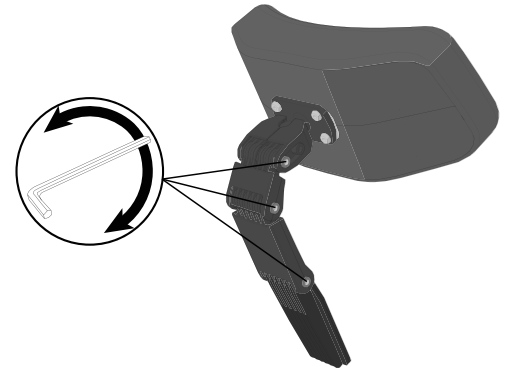


Figure 130. Adjust height and depth.

4.1.2.5 Headrest angle

1. Undo the front screw in the top link (A).
2. Adjust the headrest angle by freely changing the position of the headrest as required (B).
3. Tighten the screw.



NOTICE

Risk of damaging mechanism

Do not put weight on the headrest while adjusting it.

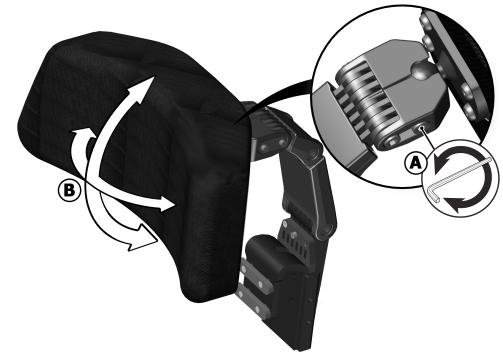


Figure 131. Adjustment of headrest angle.

4.1.3 Backrest

4.1.3.1 Removing backrest

To make transportation of the wheelchair easier, the backrest can be removed in a few simple moves.

1. Remove the backrest cushion. It is fixed in place by means of Velcro on the rear of the cushion.
2. Remove the upper section of the backrest by carefully undoing the clip on the rear of the backrest and pulling the upper section straight up at the same time.

If necessary, the headrest can also be removed; see

4.1.1 *Headrest*, Page 155.

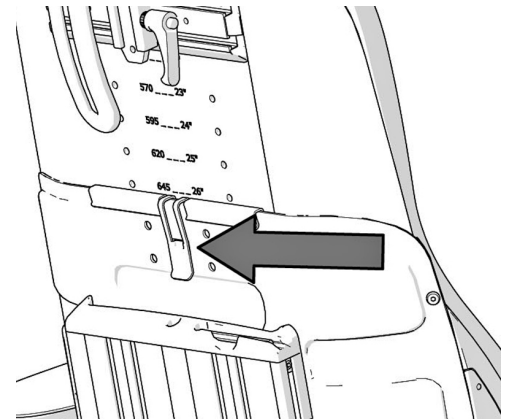


Figure 132. Clip holding the backrest.

4.1.3.2 Lumbar support

The lumbar support consists of three back cushions with Velcro fastening which can be separated, depending on how much lumbar support is required.

1. Remove the backrest cushion.
2. Adjust the lumbar support as required.
3. Re-fit the backrest cushion.

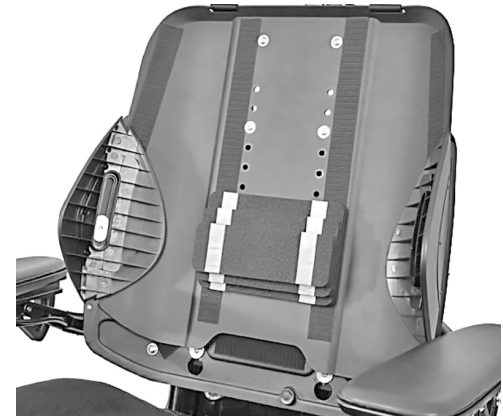


Figure 133. Lumbar support

4.1.3.3 Trunk support

The height of the trunk support is adjustable.

1. Remove the backrest cushion.
2. Undo the screw on the rear of the backrest holding the trunk support in place.
3. Adjust the trunk support as required.
4. Tighten the screw.
5. Re-fit the backrest cushion.

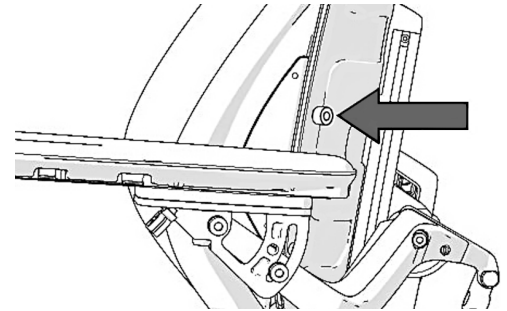


Figure 134. Trunk support screw.

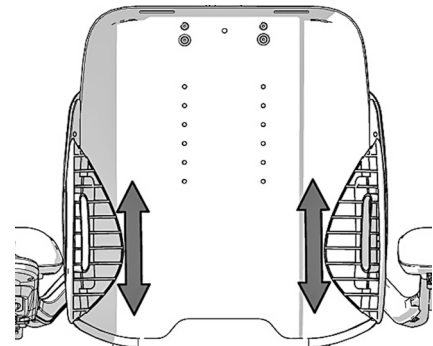


Figure 135. Adjusting trunk support height.

4.1.4 Armrest



WARNING!

Risk of injury while adjusting armrests

Do not subject the armrests to load while adjusting.

4.1.4.1 Armrest rotation

i This function is optional

The armrests can be angled inwards or outwards in order to provide optimal comfort for the user. The angle can be changed by pushing the front section of the armrest in or out.



WARNING!

Driving with armrest pointing outwards

Do not pass through narrow passageways with the armrest pointing outwards. This may lead to personal injury and property damage, including damage to the wheelchair.

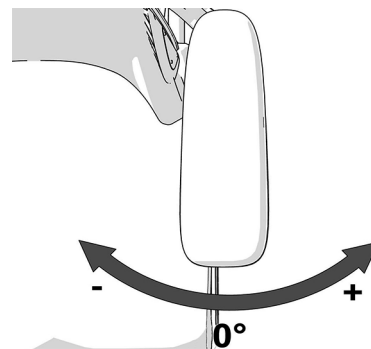


Figure 136. Adjusting the armrest angle.

Setting armrest rotation in end position

The end positions are set by moving one or two screws between three different positions underneath the armrest. Fold the armrests up to get easier access to the screws.

1. Fold up the armrest.
2. Remove the screws underneath the armrest.
3. Insert the screws in the preferred positions.
4. Fold down the armrest.



Figure 137. Adjusting the armrest rotation end position.

4.1.4.2 Armrest height

The following tools are necessary for this task:

- 1 Allen key, 5 mm.

The height of the armrest is adjustable for optimal comfort. Refer to the scale on the centre of the backrest to see the current height of the armrest.

1. Loosen the four screws on the rear of the backrest that secure the height of the armrest.

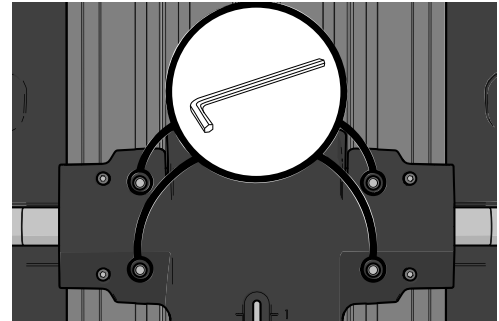


Figure 138. Adjusting the armrest height.

2. Remove the adjustment crank.

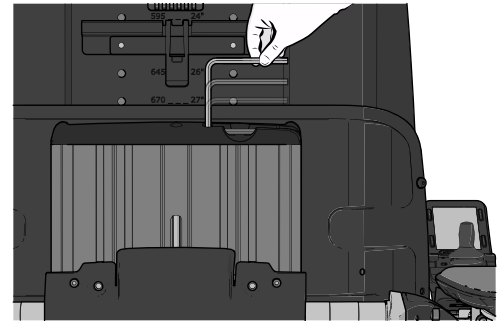


Figure 139. The adjustment crank is located in the backrest profile.

3. Adjust the armrests to the required position using the adjustment crank in the adjustment screw on the rear of the backrest.
4. Secure the height of the armrest by tightening the four screws on the rear of the backrest.

4.1.4.3 Armrest length

The armrest pads can be replaced and are available in different lengths and with different upholstery.



Figure 140. Use the supplied adjustment crank.

4.1.4.4 Armrest angle

The armrests are both individually foldable. The armrest angle can easily be adjusted for optimal comfort.

1. Loosen the two lock nuts on the adjustment bars.
2. Adjust the armrest angle by turning the adjustment bars.
3. Tighten the two lock nuts to secure the adjustment bars in position.



WARNING!

Risk of injury while adjusting armrests

Do not subject the armrests to load while adjusting.



Figure 141 . Armrest angle adjustment bars.

4.1.4.5 Armrest height and angle

The following tools are necessary for this task:

- 1 Allen key, 8 mm.

The armrest height and angle are normally adjusted as described previously. However, for special needs, the armrests are adjustable individually for users who want a left and right armrest at different heights and/or angles. The angle of the armrest is secured using a screw.

1. Loosen the two nuts (D) securing the position of the adjustment bar.
2. Adjust the armrest by turning the adjustment bar (C).
3. Secure into position by tightening the lock nuts (D).
4. Secure the armrest angle by moving the screw from a fixed position (A) to a flexible position (B).
5. Adjust the armrest to the required angle.
6. Secure by tightening the screw (B).

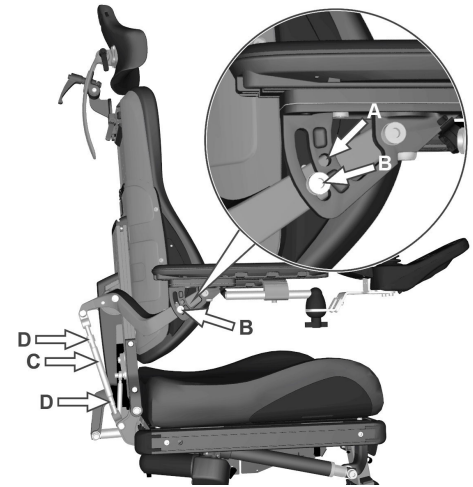


Figure 142. Adjusting the armrest height and angle.

**NOTICE****Armrest flexible position**

This type of adjustment should only be made for special needs. It may have negative effects on the movement of the armrest when raising or lowering the backrest

**WARNING!****Risk of injury while adjusting armrests**

Do not subject the armrests to load while adjusting.

4.1.5 Leg support

**WARNING!****Risk of injury while working on the leg support**

Do not place any weight on the leg support while working on it.

4.1.5.1 Leg support top cover

The leg support cover must be removed in order to adjust the leg supports.

1. Remove the leg support cover by undoing the two screws.
2. Pull the cover directly forward.
3. Adjust the leg supports as preferred.
4. Push the leg support cover into place.
5. Secure the cover with the two screws.

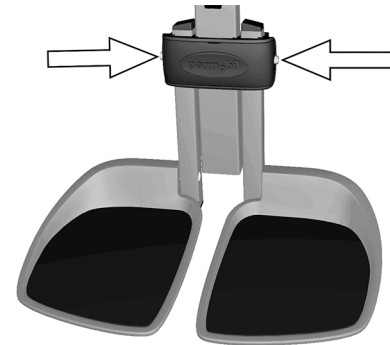


Figure 143. Adjustment screws for leg support cover.

4.1.5.2 Leg support length

The leg support length is adjustable continuously and secured using two locking screws.

1. Remove the leg support cover.
2. Undo the leg support's two inner locking screws.
3. Adjust the leg support to the required length and secure by tightening the locking screws.
4. Check that the leg support is fully secured.
5. Re-fit the leg support cover.



WARNING!

Risk of injury – adjust floor-to-footplate clearance

After adjustment, and with the seat lift in its lowest position, make sure there is sufficient clearance, at least 25 mm, between the ground and the footplate at all times when moving the leg support in or out. Perform this test with the user sitting in the wheelchair with his or her feet on the footplates.

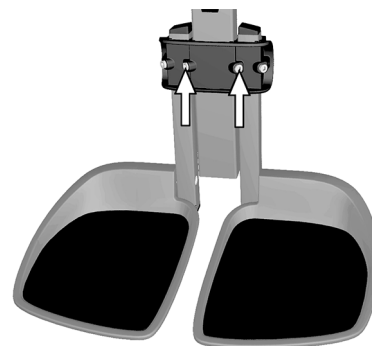


Figure 144. Adjustment screws for leg support cover.

4.1.6 Footplates



WARNING!

Risk of injury while adjusting footplates

Do not place any weight or load on the footplates while adjusting the footplates.

4.1.6.1 Footplate height

The height of the footplates is individually and steplessly adjustable. They are secured using the two outer locking screws.

1. Remove the leg support cover.
2. Undo the footplates' locking screws.
3. Adjust the footplates to the required height and secure by tightening the locking screws.
4. Check that the footplates are fully secured.
5. Replace the leg support cover.

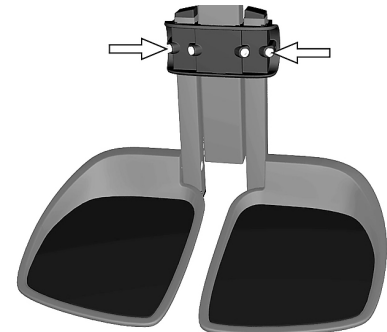


Figure 145. Adjusting footplate height.

**WARNING!****Risk of injury – adjust floor-to-footplate clearance**

After adjustment, and with the seat lift in its lowest position, make sure there is sufficient clearance, at least 25 mm, between the ground and the footplate at all times when moving the leg support in or out. Perform this test with the user sitting in the wheelchair with his or her feet on the footplates.

4.1.6.2 Footplate angle

The angle of the footplates is adjusted using detent screws under each footplate.

1. Tilt up the footplate.
2. Undo the lock nut.
3. Set to the required angle by adjusting the detent screw in or out.
4. Lock the stop screw in the required position using the lock nut.

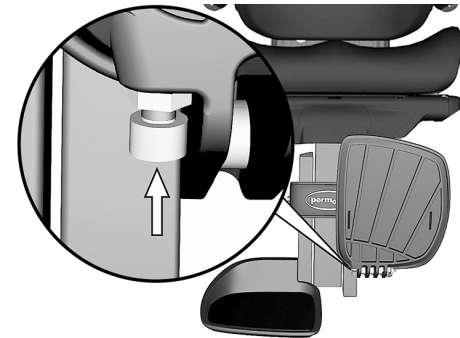


Figure 146. Footplate angle detent screw.

4.1.7 Knee support

For this task, the following tools are necessary:

- 1 Allen key 4 mm.
- 1 Allen key 5 mm.



WARNING!

Leg support actuator – do not use on its own

You cannot operate the leg support actuator on its own when the knee support is fitted. If the actuator is operated on its own while the knee support is fitted, it may lead to serious injury.



WARNING!

Adjustment by authorised technician

This product must be adjusted by an authorised service technician. If the product is wrongfully adjusted, it can cause damage to the user and/or the product.

4.1.7.1 Knee support depth

The depth of the knee support can be adjusted to give the user optimal comfort.

Rotate the knob clockwise or anti-clockwise to adjust the knee support to a suitable depth.

There should be approximately 2,5 cm of space between the knee support and the leg when adjusted correctly in a seated position.



Figure 147. Adjusting the knee support depth.

4.1.7.2 Knee support width

The width of the knee supports can be adjusted to give the user optimal comfort.

Loosen the two screws and adjust the knee support pad to a suitable position. Retighten the screws to fix into position.

You can customise how embracing the knee pads are by bending them with your hands.

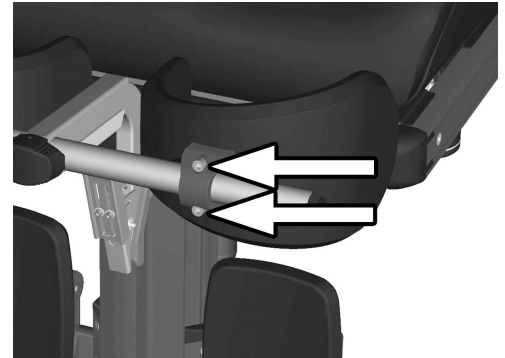


Figure 148. Adjusting the knee support width.

4.1.7.3 Knee support height



WARNING!

Risk of injury - check pole lock

Check that the pole is locked in position by pulling the support frame upwards. Failure to lock the pole correctly may lead to personal injury.

The height of the knee supports can be adjusted to give the user optimal comfort.

Remove the screw and position the quick lock to a suitable position. Refit the screw to fix into position.

4.1.8 Panel holder

i The control panel holder can be mounted on the left or right armrest.

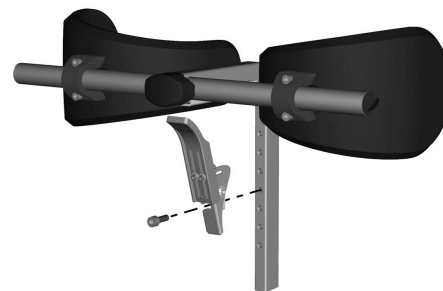


Figure 149. Adjusting the knee support height.

4.1.8.1 Rotational panel holder

The location of the control panel is adjustable lengthwise for the optimal driving position. It is also possible to adjust the angle of the panel sideways to facilitate getting in and out of the wheelchair.

Length adjustment

1. Undo the screw (A) on the panel joint and adjust the panel to the required position.
2. Tighten the screw.

Angle adjustment with friction hinge

Using the knob (B) on the friction hinge, it is possible to adjust how easily the panel can be pushed out to the side.

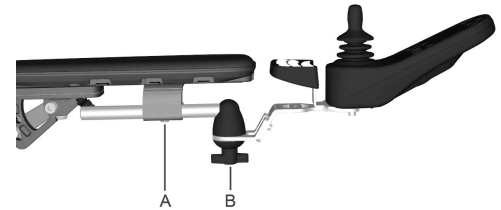


Figure 150. Rotational panel holder overview

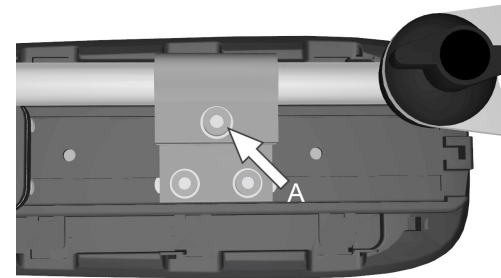


Figure 151. Screw for adjusting the panel holder length

Control panel sliding angle adjustment

1. Remove one of the screws. Choose the side that is desired to be sliding.

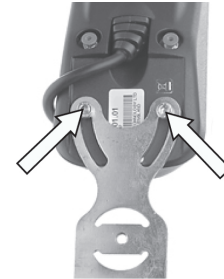


Figure 152. Only remove one of the screws.

2. Angle the panel.
3. Refit the screw. Tighten the screw to the preferred friction.

4.1.8.2 Parallel panel holder

- Allen key, 4 mm.
- Allen key, 5 mm.



Figure 153. The slide tracks.

Length adjustment

1. Undo the screw(s) on the underside enough to slide the panel holder.
2. Adjust the panel to the preferred position. Leave at least a gap of 10 mm between the armrest and the panel.
3. Tighten the screw. Tightening torque 9.8 Nm.

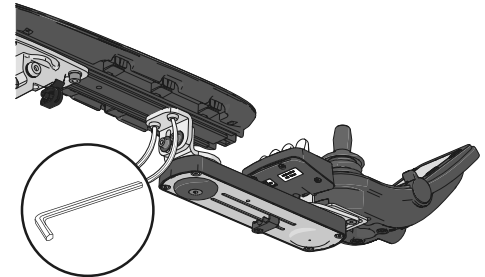


Figure 154. The position of the screws on the parallel panel holder.

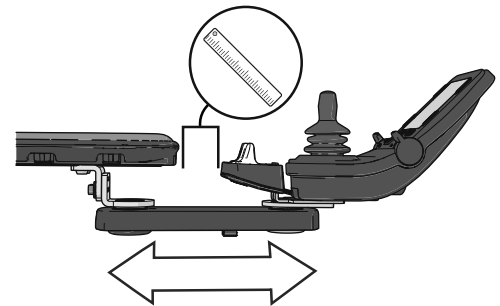


Figure 155. Adjusting the position on the parallel panel holder.

Adjusting the friction hinge

1. Undo the screw to make the friction joint more loose.

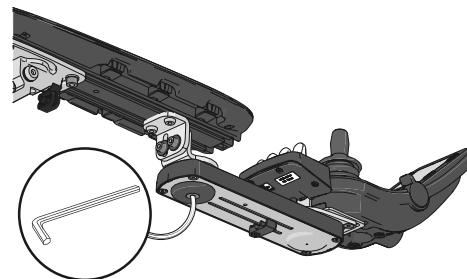


Figure 156. The screw's position on the parallel panel holder.

2. Slide the panel to the preferred position.
3. Tighten the screw to keep it in position.

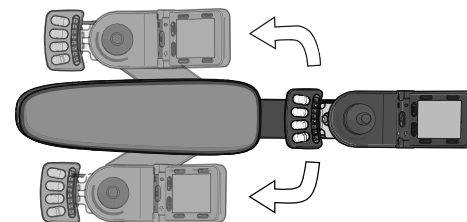


Figure 157. Slide the panel and the panel holder to preferred side of the armrest.

4.1.9 Positioning belt

i Accessory

There is an accessory rail on each side of the seat frame intended for attaching a positioning belt, etc. The positioning belt should be fitted in the rail's upper groove.

1. Screw the belt in place, with the quick lock on whichever side suits the user best and the other part with the buckle on the opposite side.

2. Check that the belt buckle locks properly in the quick lock.



Figure 158. Attaching the positioning belt



Figure 159.

**WARNING!****Use installed positioning aids**

The user must use and securely fasten the positioning belt and any other positioning aids on the wheelchair. Failure to properly use positioning belts and other positioning aids may cause bodily injury. If there is any sign of damage or wear on any positioning belt or aids, immediately contact Permobil for a replacement.

**WARNING!****Positioning belts and aids are not vehicle seatbelts**

The wheelchair positioning belt and aids are designed to properly position the user in the wheelchair for safely operating the wheelchair. The wheelchair positioning belts and aids do not provide protection in a traffic accident and do not replace a vehicle mounted seatbelt.

4.2 Handling and driving

The wheelchair is designed for use both indoors and outdoors. When driving indoors, take care in e.g. narrow passages, when passing through doors and entrances and when using lifts, ramps, etc.

Also bear in mind the crush hazard when using the powered seat lift and seat angle functions, especially if the wheelchair has been driven under a table, bench, etc. When driving outdoors, remember to drive very slowly down steep slopes and to take great care when driving on uneven surfaces, up slopes, on side slopes and over obstacles. Always observe a good safety distance when driving near edges and drops.

We recommend users make repeated test drives in environments where they feel safe to familiarise themselves with how the wheelchair and its accessories behave in different situations before starting to use the wheelchair on public roads and in other public spaces.

4.2.1 General - driving

Check that the control panel is correctly fitted and the joystick is in the neutral position. Make sure you have good support, for example, the wheelchair's armrest, for the part you use to handle the joystick. Do not use the joystick alone as a support. Fast turns and driving on uneven surfaces can interfere with your ability to handle the wheelchair safely.

1. Switch on the power.
2. Select a suitable driving profile with the Profile button (if the system is programmed for more than one driving profile).
3. Move the joystick carefully forward to drive forward or backward to reverse.
4. Adjust the speed setting with the higher and lower speed buttons. The wheelchair's electronics allow very slow driving over obstacles. Drive up to the obstacle, then carefully drive over it.

**WARNING!****Risk of injury - place your feet correctly**

Always make sure your feet are correctly and securely positioned on the footplates before you operate the wheelchair. Use foot straps if necessary. Failure to do so increases the risk of personal injury.

4.2.2 Manual brake release

The wheelchair is fitted with two manual brake releases acting on the magnetic wheel locks to allow manual movement of the wheelchair.



WARNING!

Wheel locks

Do not release or engage the wheel locks unless power to the wheelchair is off.

To prevent the wheelchair rolling away, make sure it is on a level surface before releasing the wheel locks.

Be aware that the wheelchair has no brakes when the wheel locks are in free-wheel position.

Make sure that the person pushing the wheelchair has full control when the wheel locks are released.

Always engage the wheel locks after the wheelchair has been pushed manually.

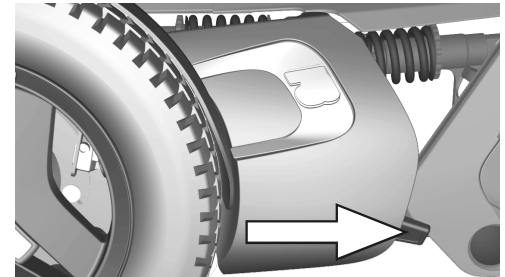


Figure 160. Release lever location.

4.2.2.1 Releasing wheel locks

1. Switch off the wheelchair using the start button on the control panel.
2. Move the lever downwards to release the brakes. The wheelchair can now be moved manually.



WARNING!

Malfunctioning wheel locks

When the wheel locks are released, the wheelchair cannot be driven. If it can be driven, contact an authorised Permobil service centre as soon as possible.

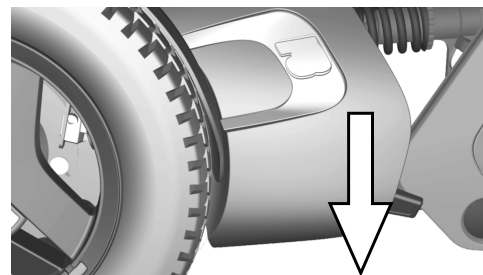


Figure 161 . Releasing wheel lock.

4.2.2.2 Engaging wheel locks

1. Switch off the wheelchair using the start button on the control panel.
2. Move the lever upwards to its uppermost position to engage the wheel lock.

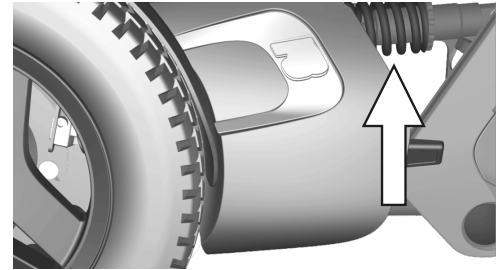


Figure 162. Engaging wheel locks.

4.2.3 Support wheels

The wheelchair may be fitted with support wheels to reduce the risk of tipping when driving over obstacles, etc. They must always be fitted when you drive. Should your weight increase to more than 100 kg or should you wish to increase the speed of your wheelchair to 10 km/h or more than that, the support wheels must be installed.



WARNING!

Risk of tipping - do not remove support wheels

If the wheelchair is fitted with support wheels, they must remain fitted to reduce the risk of the wheelchair tipping forward due to speed or prevailing circumstances. It is important to drive the wheelchair at a safe speed to reduce the need for sudden stops that may cause the wheelchair to tip forward. See pages page 197 — page 199. Always be aware of the seat position and how it might affect the stability of the wheelchair on different surfaces, even with support wheels.

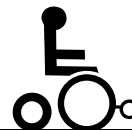


Figure 163. Support wheels.

4.2.4 Driving technique

The control panel electronics interpret joystick movements and move the wheelchair accordingly. No complex user techniques are required for normal driving, which is an advantage if the user is inexperienced. A good way to get started is simply to move the joystick in the direction you want to go. The wheelchair will then move in the direction in which the joystick is pointing.

However, always remember to drive as gently as possible and to avoid sudden braking and evasive manoeuvres.

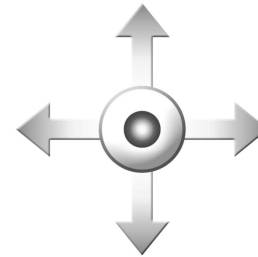


Figure 164. Joystick manoeuvring.



CAUTION!

First test drive

Do not take the first test drive alone. The test drive is intended to establish how you and the wheelchair work together and you may need assistance.

Before driving, check that the brake release lever is in the drive position.

**CAUTION!****Driving - surface conditions**

Never drive at full speed in narrow or confined spaces or on sloping or inclined surfaces. Use extra caution when driving the wheelchair on surfaces that have ridges that could cause the chair to steer in a different direction.

**WARNING!****Release the joystick at the first sign of unexpected behaviour!**

Do not use the joystick as a support. Fast turns and driving on uneven surfaces can interfere with your ability to handle the wheelchair safely.

If the wheelchair moves in a way that you do not want, **release the joystick!** This always makes the wheelchair stop whatever it is doing.

4.2.5 Driving restrictions



WARNING!

Risk of tipping over

Do not allow the leg support to hit the ground when climbing obstacles, driving on uneven surfaces or slopes or when a slope levels out. Make sure there is sufficient ground clearance to avoid the risk of tipping over.

4.2.5.1 Driving restrictions related to different surfaces

Do not drive at high speed, avoid sudden stops and starts, avoid sudden evasive manoeuvres or sharp turns and use extreme caution in any of the following situations:

- when near edges and drops or on elevated surfaces,
- when on soft or uneven surfaces; such as grass, gravel, sand, ice, snow,
- when driving from an area of high traction (e.g. pavement) to an area of low traction (e.g. grass),
- when turning the wheelchair,
- when in narrow or confined spaces, and
- when driving on surfaces that have ridges that could cause the wheelchair to move in a different direction.

These restrictions also apply to subsequent sections.

4.2.5.2 Driving over obstacles

You may drive over obstacles up to 100 mm, as long as 4 of the 6 wheels stay in contact with the obstacle's surface as the transition from front to rear takes place.

Use extreme caution when negotiating obstacles of this type. Always approach the obstacle at a right angle. If you drive over higher obstacles, there is a greater risk of tipping and of damage to the wheelchair.



WARNING!

Driving - high obstacles

Do not drive the wheelchair over obstacles higher than 100 mm. Always exercise great caution when driving over obstacles.

Because a raised seat lift, seat tilt and/or back angle changes the centre of gravity and increases the risk of tipping, only use these seat functions on flat surfaces and always drive with great caution and at low speed.



Figure 165. Driving over obstacles.

4.2.5.3 Driving on side slopes

Always exercise great caution when driving over side slopes.

Avoid sudden evasive manoeuvres and never drive so fast that you are unable to control the wheelchair safely and without risk.



WARNING!

Risk of tipping on uneven surfaces

Take great care when driving on side slopes with an uneven surface (e.g. grass, gravel, sand and snow).



WARNING!

Risk of tipping on steep slopes

Do not drive the wheelchair on side slopes steeper than . There is a risk of tipping over.

Because a raised seat lift, seat tilt and/or back angle changes the centre of gravity and increases the risk of tipping, only use these seat functions on flat surfaces and always drive with great caution and at low speed.



Figure 166. Driving on side slopes.

4.2.5.4 Driving downhill

Always drive downhill at low speed and with great caution.

Note that the distance required to stop will increase when driving downhill.

Avoid braking suddenly and sudden evasive manoeuvres and never drive so fast that you are unable to control the wheelchair safely and without risk.



Figure 167. Driving downhill.



WARNING!

Risk of tipping on uneven surfaces

Take great care when driving on side slopes with an uneven surface (e.g. grass, gravel, sand and snow).



WARNING!

Risk of tipping when driving downhill

Do not drive downhill on gradients greater than 12°.

Because a raised seat lift, seat tilt and/or back angle changes the centre of gravity and increases the risk of tipping, only use these seat functions on flat surfaces and always drive with great caution and at low speed.



WARNING!

Increased stopping distances

The distance required to stop the wheelchair will increase when driving downhill.

4.2.5.5 Driving uphill

Always drive uphill with great care.

Avoid sudden evasive manoeuvres and never drive so fast that you are unable to control the wheelchair safely and without risk.



WARNING!

Risk of tipping on uneven surfaces

Take great care when driving on side slopes with an uneven surface (e.g. grass, gravel, sand and snow).



WARNING!

Risk of tipping when driving uphill

Do not drive uphill on gradients greater than 12°.

Because a raised seat lift, seat tilt and/or back angle changes the centre of gravity and increases the risk of tipping, only use these seat functions on flat surfaces and always drive with great caution and at low speed.



Figure 168. Driving uphill.

4.2.6 Joystick error

4.2.6.1 Joystick error at startup

Do not move the joystick before, during or immediately after the control system is switched on. If the joystick is moved from the central position, a joystick error may be generated.

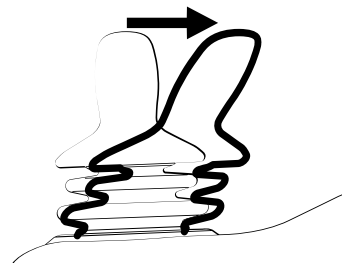
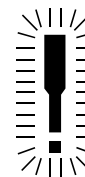


Figure 169. Joystick moved from the central position.

4.2.6.2 Joystick error LCD panel

While the control system checks if an error has occurred, the screen image for a shifted joystick will be displayed for 5 seconds.

If the control system detects an error in the wheelchair electronics, a diagnostics screen will appear. To enable the wheelchair to be driven again, make sure the joystick is in the central position. Then switch the wheelchair off and on again. If this does not work and the diagnostic screen still appears, contact your service provider.



PM
Low Battery

2C00

Figure 170. The LCD diagnostics screen.

4.2.6.3 Joystick error LED panel

While the control system checks if an error has occurred, the LEDs on the battery voltage indicator will wander backward and forward.

If the control system detects an error in the wheelchair electronics, the battery voltage indicator LEDs will flash rapidly. To enable the wheelchair to be driven again, make sure the joystick is in the central position. Then switch the wheelchair off and on again. If this does not work and the LEDs still flash rapidly, contact your service provider.

4.3 Batteries

How frequently you need to charge the wheelchair's batteries will depend on a number of factors including how you use the wheelchair, the temperature and the age of the batteries. All batteries gradually lose capacity as they age.

The most important factor for the life of the batteries is how much power is taken out of them before they are charged and how often they are charged or discharged.

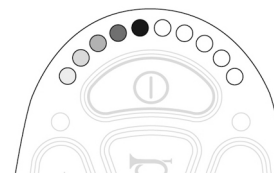


Figure 171. The LEDs on the battery voltage indicator.



NOTICE

Discharged batteries

Should the batteries be drained completely, charge them again as soon as possible since completely drained batteries may reduce battery service life.

To achieve the best service life, never let batteries discharge completely. Always charge the batteries immediately after they have been discharged.

If the battery voltage indicator shows that the batteries lose power faster than normal, the batteries could be worn out and need to be replaced.

4.3.1 Charging the batteries

If the wheelchair is switched on during the charging process, the battery voltage indicator bars on the wheelchair control panel will climb to show that the battery is being charged.

If the power on the wheelchair is turned On during the charging process, it must be switched off again and the charger disconnected before the wheelchair can be driven. Use the On/Off button on the control panel.

Figure 172. Charging socket

**NOTICE****Battery charger - see supplied manual**

For a description and battery charger instructions, refer to the manual supplied.

**WARNING!****Risk of fire or explosion - charging conditions**

Use only the charger supplied with your wheelchair or a charger recommended by Permobil. The use of other chargers may damage the batteries, the wheelchair electronics or the charger itself. It may also result in parts becoming overheated, which may entail a greater risk of fire.

Only use chargers with a max 10 A charging current (average value). The effective value of the charging current must not exceed 12 A. The batteries must be charged in a well-ventilated room, not in a cupboard. The batteries must not be charged in a bathroom or wet room.

**WARNING!****Risk of fire or explosion - do not short-circuit**

Exercise caution when using metallic objects during work with batteries. A short-circuit can easily cause an explosion. Always use safety gloves and goggles.

**WARNING!****Risk for overheating, sparks or short-circuit**

To interrupt the charging process, turn off the power supply at the switch on the charger before removing the charging plug from the wheelchair's charging socket. This is to avoid sparking and unnecessarily high wear on the charging plug.

The charger may get hot and must not be covered. The charger must be placed so that it has free space on all sides.

The charging jack must be replaced if it is damaged or gets hot during charging. Both the jack on the charger cable and the wheelchair's charging socket must be replaced if one part is damaged or worn. The contacts must be replaced by qualified personnel.

**NOTICE****Procedures when charging the batteries**

The charging cable must not be extended.

Carefully read the instructions supplied with the charger before starting to charge the wheelchair.

The main circuit breaker must be set to On to charge the batteries.

Make sure the charging plug is fully inserted in the wheelchair's charging socket.

The wheelchair cannot be driven when the charger is connected. If it is possible to drive the wheelchair during charging, contact Permobil or your dealer.

4.4 Transporting the wheelchair

4.4.1 Vehicle transportation

The wheelchair may only be transported in vehicles approved for this purpose.

Check that the wheelchair is properly secured and that the wheel locks are engaged. When transporting it in a vehicle, the wheelchair must be secured in position by attaching straps to the tie-down eyes at the front and rear, marked with yellow stickers.

Secure the wheelchair according to the instructions from the manufacturer of the approved vehicle restraint system. Always make sure that the tie-down points in the transporting vehicle are well-anchored.

- i** To make transportation of the wheelchair easier, the backrest can be removed or folded down in a few simple moves; see 4.1.3.1 *Removing backrest*, Page 161
If necessary, the headrest also can be removed; see



Figure 173. Sticker showing the location of the tie-down eyes.

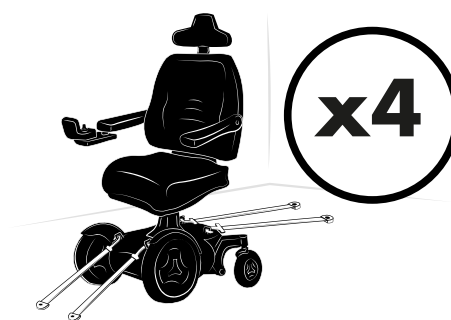


Figure 174. The wheelchair has four tie-down points. The wheelchair and tie-down position in this picture is generic.

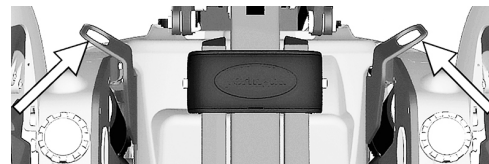


Figure 175. Front tie-down eyes.

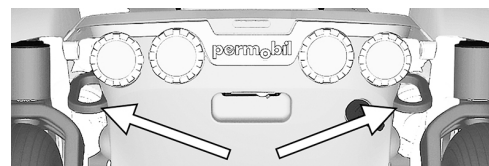


Figure 176. Rear tie-down eyes.

**DANGER!****User transportation in wheelchair**

When the user is seated in the wheelchair during transport, the following requirements must be met:

- The vehicle must be equipped with a locking system approved by Permobil for the product concerned. For alternative vehicle securement options, please consult your dealer.
- The locking system must be dimensioned for the total weight of the wheelchair.
- The user must use a three-point seatbelt attached to the vehicle.
- The wheelchair must be crash tested and approved.
- The wheelchair must be fitted with a headrest during transit.
- Alterations or substitutions should not be made to wheelchair securement points, structural parts, frame parts or components without consulting Permobil or the dealer.
- Spill-proof sealed batteries, such as gel or AGM, must be used.
- Make sure that wheelchair components do not accidentally press down the seatbelt's release button.

If these requirements are not followed, the user can sustain bodily injuries or die.

- ⓘ Permobil recommends that the wheelchair user is transferred to a vehicle seat and that he or she uses a factory-installed three-point seatbelt.

**WARNING!****Remove installed trays**

To reduce the risk of injury to the user and other vehicle occupants, wheelchair-installed trays that are not specifically designed for crash safety should:

1. be removed and secured separately in the vehicle, or
2. be secured to the wheelchair but positioned away from the user with energy-absorbing padding placed between the tray and the user.

**DANGER!****Risk of injury – correct seatbelt positioning**

The correct position for the vehicle's three-point seatbelt is on the inside of the wheelchair armrest. The three-point seatbelt should fit snugly to the user's body without anything in the way. Failure to correctly position the three-point seatbelt may cause injury and/or death, if the vehicle is in an accident.

**WARNING!****Requirements for vehicles used for transportation**

The wheelchair may only be transported in vehicles approved for this purpose. Make sure the vehicle is suitably designed and equipped to transport a person in a wheelchair and that the tie-down points on the transporting vehicle are well-anchored.

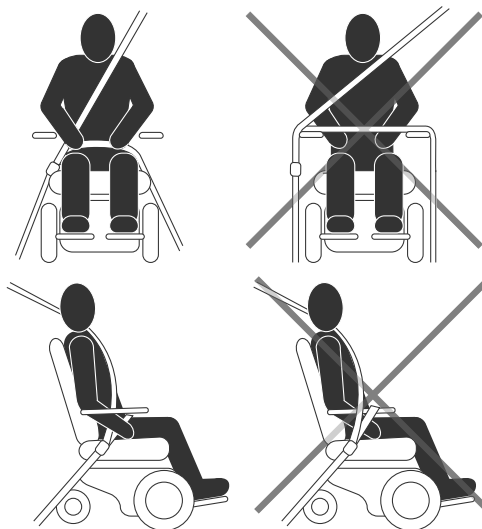


Figure 177. The illustrations on the left show correct positioning of the seatbelt positioning.

**CAUTION!****Damage during transportation**

It is extremely important to inform Permobil as soon as possible after the event if the wheelchair and its accessories have suffered transportation damage, damage during driving or damage from other causes. There is a risk that the wheelchair and its accessories can no longer be used safely and securely. Contact your service provider or Permobil for further information. Refer to page 5.

**WARNING!****Positioning belts and aids are not vehicle seatbelts**

The wheelchair positioning belt and aids are designed to properly position the user in the wheelchair for safely operating the wheelchair. The wheelchair positioning belts and aids do not provide protection in a traffic accident and do not replace a vehicle mounted seatbelt.

**WARNING!****Use installed positioning aids**

The user must use and securely fasten the positioning belt and any other positioning aids on the wheelchair. Failure to properly use positioning belts and other positioning aids may cause bodily injury. If there is any sign of damage or wear on any positioning belt or aids, immediately contact Permobil for a replacement.

**WARNING!****Secure loose objects during transportation**

Auxiliary wheelchair equipment, loose or mounted on the wheelchair, must either be secured to the wheelchair or removed from it. Dismantled or movable auxiliary equipment must be properly secured in the vehicle during transit. This is to prevent loose parts or parts that may come loose from causing injury to the occupants during transit.

**WARNING!****Securing the wheelchair in vehicles**

The wheelchair may only be secured in position using approved fastening straps or a locking system. The locking system must be approved for the Permobil product concerned.

Secure the wheelchair by attaching approved fastening straps to the eyes at the front and rear, marked with yellow stickers. Do not attach the fastening straps to any other part of the wheelchair. Secure the fastening straps to the vehicle according to instructions for the restraint system in the vehicle.

Always make sure that the tie-down points in the transporting vehicle are well-anchored.

Check that the brake release on the wheelchair is set to locked position.

4.4.1.1 Car lock

Dahl docking station

See the Dahl docking station's manual on how to operate it.

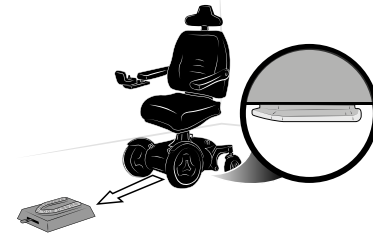


Figure 178. The Dahl docking station. The wheelchair in this picture is generic.

Permolock C3

See the Permolock C3 manual on how to operate it.

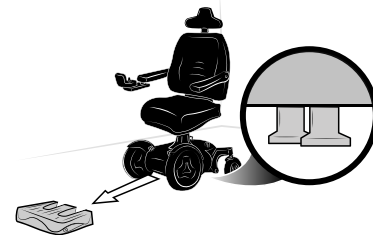


Figure 179. The Permolock C3 docking station. The wheelchair in this picture is generic.

4.4.2 Air transportation



NOTICE

Preparations for air transportation

Airlines have different rules regarding wheelchair transportation. Please contact your specific airline for more information and to make sure the wheelchair can be transported safely.

4.4.2.1 Batteries

Gel batteries: in most cases, gel batteries do not have to be removed from the wheelchair.

The main circuit breaker must always be in the Off position.

Acid batteries: most airlines require that batteries be removed from the wheelchair and transported in special boxes that the airline may provide.

4.4.2.2 The wheelchair's dimensions and weight

The wheelchair's weight and dimensions are important, depending on the size and type of aeroplane in which the wheelchair is to be transported. Always check with the airline what rules apply.

4.4.2.3 Preventing damage to wheelchair

Since the wheelchair will be put with other goods in a confined space during the flight, it is important to take preventive measures to minimise transportation damage to the wheelchair.

Cover the control panel with soft, shock-absorbing material (foam plastic or similar) and turn the control panel in towards the backrest. Protect other protruding objects in a similar manner. Where possible, adjust parts to the folded position. Tape any loose cables to the seat or hoods.

4.4.3 Rail transportation

Directive 2008/57/EC concerns the interoperability of the European rail network. A part of this directive contains limits for weights and dimensions. In some configurations this product might deviate from the limits specified.

5 Maintenance and repairs

5.1	Frequency of maintenance and inspection.....	221
5.2	Tool bag	222
5.3	Cleaning.....	223
5.3.1	Metal surfaces	223
5.3.2	Plastics	224
5.3.3	Upholstery, cloth and vinyl	224
5.4	Battery replacement.....	225
5.4.1	Removing batteries.....	225
5.4.2	Installing batteries	232
5.5	Batteries storage	239
5.5.1	Short-term storage	239
5.5.2	Long-term storage.....	240
5.6	Wheels and tyres	240
5.6.1	Drive wheels	240
5.6.2	Inflating tyres	251
5.6.3	Castor wheels.....	254
5.6.4	Inflating castor wheels	262

5.7	Main circuit breaker	265
5.8	Brake release	266
5.9	Positioning belt.....	266
5.10	Serial number labels.....	267
5.10.1	Serial number label on chassis	267
5.10.2	Serial number label R-net power module	268
5.10.3	Serial number label on the control panel	268

For the wheelchair to work well, it is important that it is used correctly and regularly maintained. A well maintained wheelchair lasts longer and has a lower risk of defects.

**CAUTION!****Maintenance by a qualified service technician**

Only qualified service technicians should perform the maintenance and repair specified in this manual. Read all instructions carefully before proceeding. If any questions arise, contact Permobil for assistance.

**NOTICE****When replacing batteries or circuit breakers,
switch off main circuit breaker**

The main circuit breaker must always be switched off when batteries and fuses are replaced. Always switch off the power supply to the control panel before interrupting the power with the main circuit breaker.



NOTICE

Additional tools may be required

Some repairs may require tools other than those supplied with the wheelchair.

5.1 Frequency of maintenance and inspection

Permobil recommends compliance with the following maintenance and inspection schedule. Contact your authorised dealer for all service-related needs or questions.

Maintenance and inspection schedule	Daily	Weekly	Monthly	Yearly
Check battery level indicator and charge if necessary.	X			
Check that the joystick panel and other control panels are not damaged.	X			
Make sure all removable parts are securely fastened.	X			
Check positioning belts for wear and make sure buckles work.	X			
Check tyres and inflate as necessary.		X		
If the wheelchair is equipped with lights and indicators, make sure they are operational and clean.		X		
Clean the wheelchair and upholstery.			X	
Check upholstery, seating, headrest, arm pads and calf pads for wear.			X	

Maintenance and inspection schedule	Daily	Weekly	Monthly	Yearly
Check that the brake release and the brake release lever work properly.			X	
Complete inspection, safety check and service performed by an authorised wheelchair dealer.				X

5.2 Tool bag

The wheelchair comes with a tool bag with the following contents for use for maintenance and minor repairs.

- i** Other tools may be supplied depending on wheelchair configuration.

Tool	Area of use
Allen keys.	General maintenance and seat adjustment.
11, 13 mm wrenches.	General maintenance and replacing batteries.
Valve adapter	Inflating the castor wheels

5.3 Cleaning

Regular care and maintenance will prevent unnecessary wear and damage to your Permobil product.

- i** Use only the following cleaning methods.
- i** In the case of severe soiling of the upholstery or damage to the surface finish, contact Permobil for information.



CAUTION!

Switch off the wheelchair before cleaning

Always switch off the power supply to the wheelchair before cleaning.

5.3.1 Metal surfaces

Due to the high quality powder coating, optimum corrosion protection is guaranteed. Ideally, use a soft cloth or sponge, hot water and a mild detergent for normal cleaning. Wipe down carefully with a cloth and water, and dry off.

Remove scuff marks from semi-matte surfaces with soft wax (follow manufacturer's instructions).

Remove scuff marks and scratches from shiny surfaces using car polish, either liquid or paste. After polishing, apply soft car wax to restore the original surface gloss.

5.3.2 Plastics

For normal cleaning, wash plastic surfaces with a soft cloth, mild detergent and hot water. Rinse thoroughly and dry with a soft cloth. Do not use solvents or abrasive kitchen cleaners.

5.3.3 Upholstery, cloth and vinyl

For normal cleaning, wash the upholstery with lukewarm water and a mild, non-abrasive soap. Use a soft cloth or brush. Before the surface dries, wipe off any water or soapy water residues with a clean, dry cloth. Repeat this procedure to remove stubborn dirt or stains. Ink spots can sometimes be removed by washing with soap and water followed by isopropyl alcohol.

Do not use any cleaning method that is not listed above; other methods may attack and degrade the vinyl and may void the wheelchair's guarantee.

If necessary, the cover may be removed before cleaning. See also the washing instructions on the upholstery materials.

5.4 Battery replacement

5.4.1 Removing batteries



WARNING!

Use safety gloves and safety goggles

Always use safety gloves and safety goggles when working with batteries. Exercise caution when using metallic tools or other objects while working with batteries. Batteries are heavy and charged devices and must be handled with great caution. Failure to follow any of these warnings could cause a short circuit, explosion, property damage and/or bodily harm.



CAUTION!

Recycling batteries

Used or malfunctioning batteries must be disposed of responsibly in accordance with local recycling regulations.

1. Place the wheelchair on a level surface. If possible, raise the seat lift halfway up, to facilitate removal of the chassis top cover.
2. Switch off the power supply using the On/Off key on the control panel and switch the automatic main circuit breaker to Off.

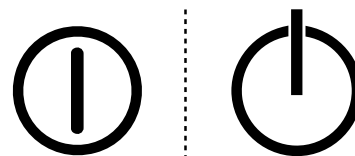


Figure 180. On/Off symbol depending on model.

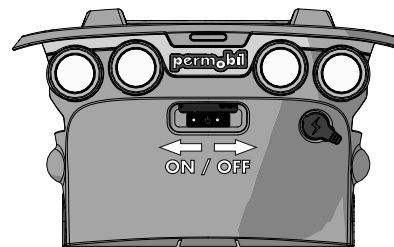


Figure 181. Main circuit breaker.

3. Remove the two knobs holding the chassis top and front covers.

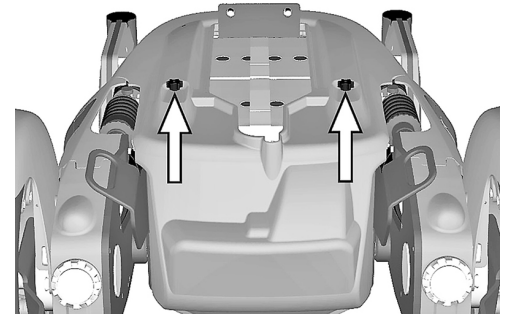


Figure 182. The chassis covers are secured with two knobs.

4. Slide the top cover off the chassis.

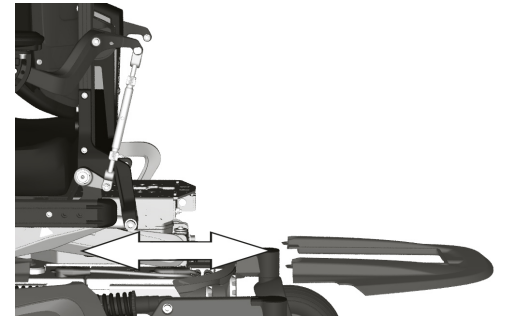


Figure 183. Top cover.

5. Pull the back cover off the dual locks and off the chassis.

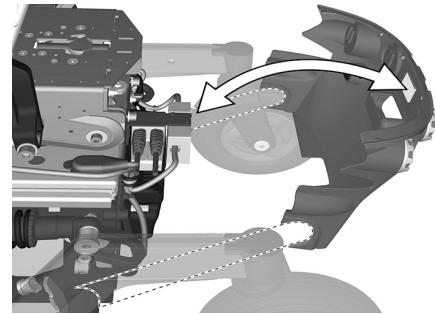


Figure 184. Back cover.

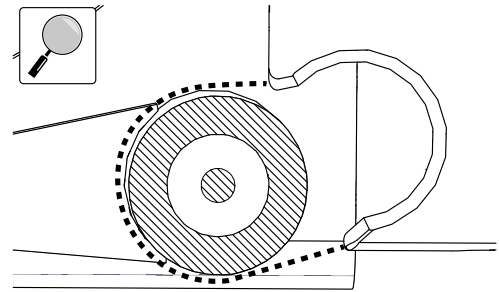


Figure 185. An enlargement of the back cover going over the rear axle.

**WARNING!****Do not burden the seat**

Do not burden the seat or the AP elevator during this operation. Any load on the seat or the AP elevator could cause permanent damage to the wheelchair or injuries to someone in the wheelchair or in its close vicinity. These conditions apply until the screws are reinstalled and tightened to the correct torque.

6. Remove the four screws holding the battery box.
7. Disconnect the right motor and inhibit cable connector (C).
8. Disconnect the left motor and the bus cable connector (B).
9. Disconnect the control panel connector (A).

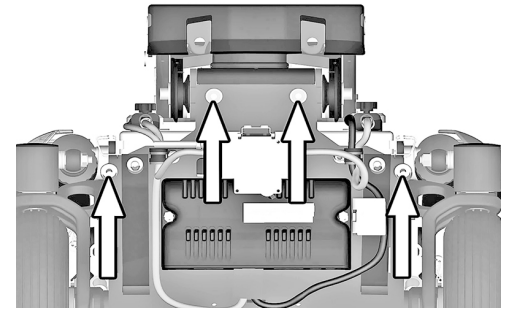


Figure 186. The battery box is secured with four bolts.

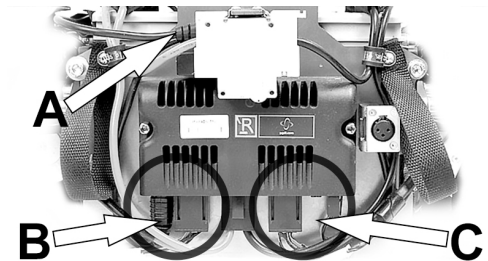


Figure 187. Connectors (B) and (C); for disconnection.

10. Use the straps to pull the battery box out of the chassis.

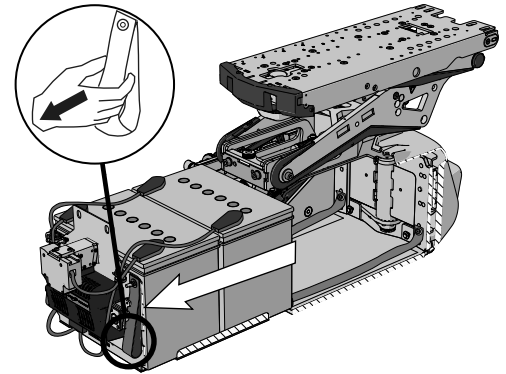
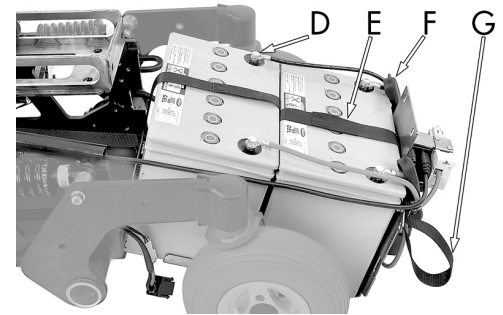


Figure 188. Straps for pulling out battery box.

11. Slide the battery terminal covers along the cables to access all four battery terminal screws.
12. Disconnect the cables from the four battery terminals.
13. Lift the batteries out of the battery box using the battery straps.



- D. Battery terminal.
- E. Battery strap.
- F. Battery terminal cover.
- G. Battery box pull-out strap.

Figure 189. Battery box when pulled out from chassis.

5.4.2 Installing batteries



NOTICE

Different types of batteries

The chair can be equipped with 60 Ah or 73 Ah maintenance-free batteries. Check carefully which battery you have.

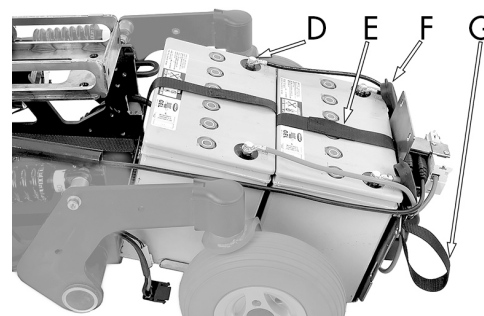


CAUTION!

Always use recommended batteries

Always use Permobil recommended batteries. Other replacement batteries have not been tested for use with Permobil wheelchairs.

1. Use the battery straps and lift the new batteries in reverse order (leave the straps on the new batteries).



- D. Battery terminal.
- E. Battery strap.
- F. Battery terminal cover.
- G. Battery box pull-out strap.

Figure 190. Battery box when pulled out from chassis.

2. Make sure the batteries are positioned correctly to bring terminals into the right position; refer to the wiring diagram. Connect the four wires to the correct terminals on the batteries as shown in the diagram. Also refer to the label inside the cover.

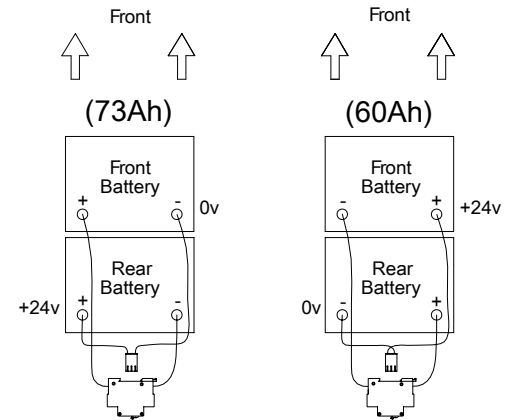


Figure 191. Wiring diagram for the battery connection.

3. Attach the cable that is connected to the rear battery's left terminal on its cable holder.

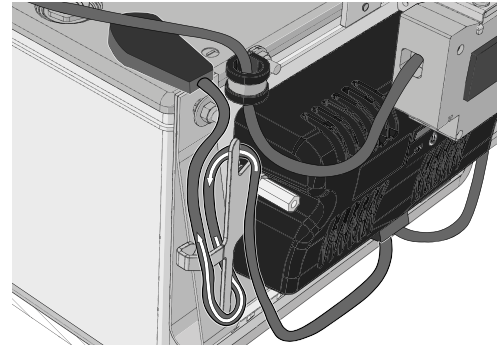


Figure 192. Attach the cable that is connected to the rear battery's left terminal on its cable holder as shown.

4. Attach the cable that is connected to the front battery's right terminal in its cable holder.

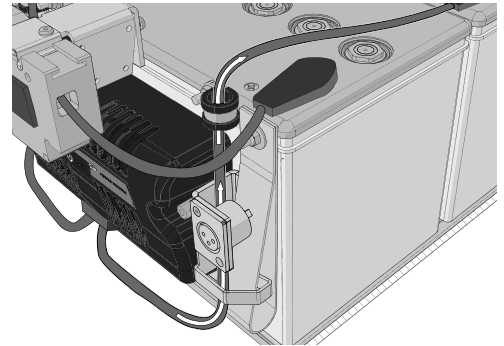


Figure 193. Attach the cable that is connected to the front battery's right terminal in its cable holder as shown.

5. Push the battery box in to the chassis.

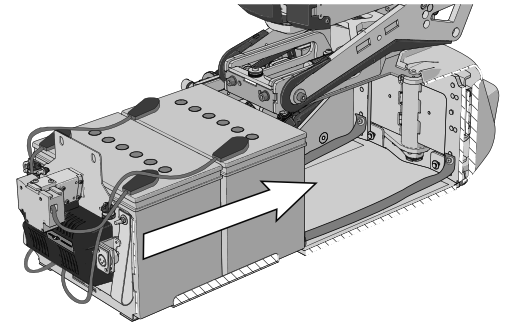


Figure 194. Push in the battery box.

6. Connect the right motor and inhibit cable connector (C).
7. Connect the left motor and bus cable connector (B).
8. Connect the control panel connector (A).

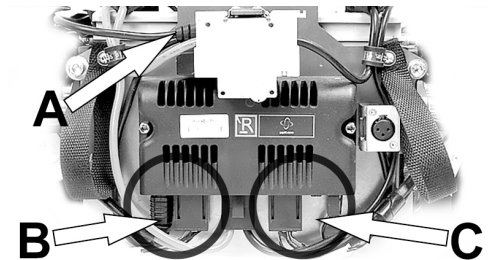


Figure 195. Connectors (B) and (C); for connection.

9. Refit the four screws securing the battery box. Use a torque wrench to tighten the screws. Tightening torque: 24 Nm.

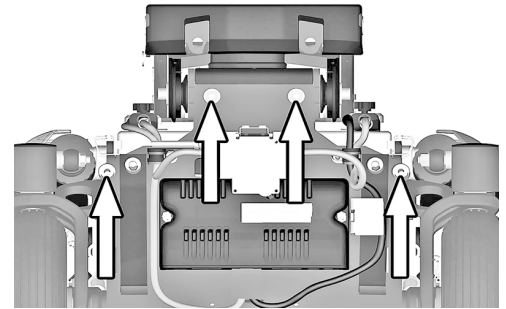


Figure 196. The battery box is secured with four bolts.

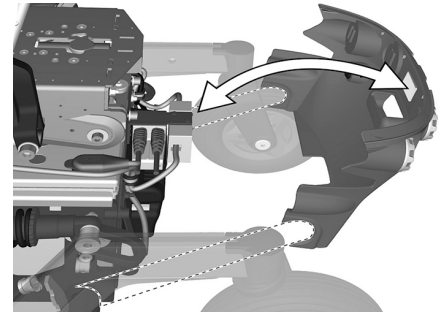
10. Refit the rear chassis cover on to the chassis.

Figure 197. Rear cover.

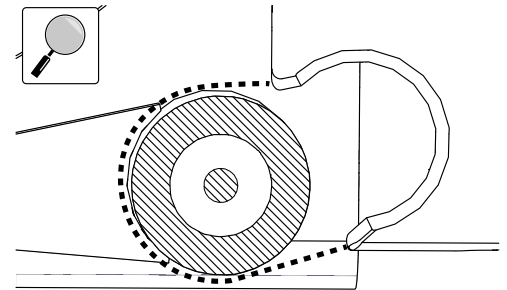


Figure 198. An enlargement of the rear cover going over the rear axle.

11. Refit the top chassis covers on to the chassis.

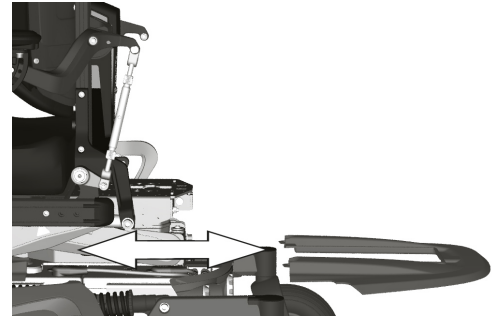


Figure 199. Top cover.

12. Refit the two knobs.

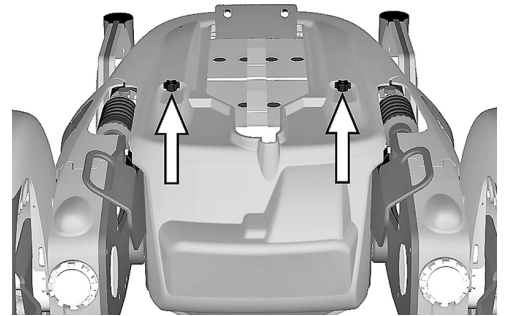


Figure 200. The chassis covers are secured with two knobs.

13. Switch the automatic main circuit breaker to the On position.

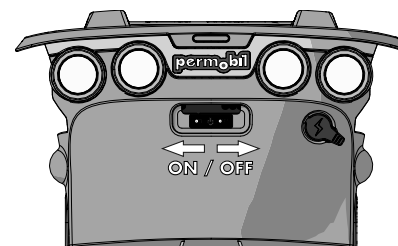


Figure 201 . Main circuit breaker located under the Permobil logotype on the rear cover.

5.5 Batteries storage

- The wheelchair must not be stored in areas subject to condensation (steam or moisture on surfaces), e.g. utility rooms or similar.
- If the wheelchair is equipped with acid batteries, the acid level must be regularly checked. If the wheelchair is equipped with gel or AGM batteries, the liquid level does not need to be checked.
- Battery service life depends on regular charging and avoiding complete discharge of the batteries.

5.5.1 Short-term storage

For short-term battery storage, the room must be at least 5°C. If the temperature is lower than this, the batteries may not charge fully and may be more vulnerable to corrosion.

5.5.2 Long-term storage

For long-term battery storage, the room may be unheated but to guard against battery corrosion, make sure the room is a few degrees warmer than its surroundings as this will keep the room drier.

Switch off the main circuit breaker to avoid complete discharge of the batteries.

The batteries must be fully charged before storage. Batteries in storage require charging every 6 months.

5.6 Wheels and tyres

5.6.1 Drive wheels

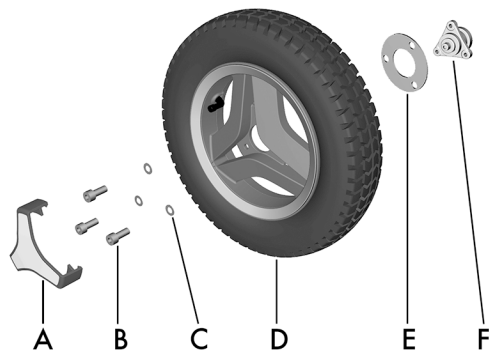


Figure 202. Installing the drive wheel.

- A. Hub cap (the design may vary depending on markets and market regulations).
- B. Screw, ISO 4762 M8x20 8.8 Fe/Zn 5 C1/ TUF-LOK DIN 267-28.
- C. Washer, ISO 7089 8 200 HV Fe/Zn 5 C1 (8,4x16x1,6).
- D. Drive wheel.
- E. Spacer, in use only when the wheelchair is fitted with winter tyres.

F. Wheel hub, do not remove the hub from the drive unit while performing service on the wheel.

The following tools are necessary for this task:

- 1 Torque wrench.
- 1 Allen key socket, 6 mm.
- 1 Jack.
- 4 Blocks for securing the wheelchair.



NOTICE

Replace used wheel screw

If a wheel screw is removed for tyre service, replace it with a new, unused screw from Permobil and tighten it to the recommended torque. Also, inspect the drive axle and wheel rim for any damage. Damage to either part can cause the wheel screw to loosen or fracture. Because the TUF-LOK thread lock fluid wears off, Permobil recommends that wheel screws only be used once.

5.6.1.1 Removing the drive wheels

- i** Do not remove the wheel hub (F) from the drive unit while performing service on a wheel.

1. Switch off the main power switch on the control panel.

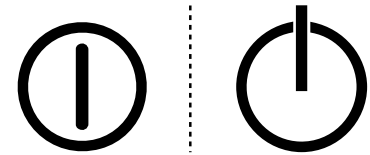


Figure 203. On/Off symbol depending on model.

2. Jack up the wheelchair until the wheel turns freely.

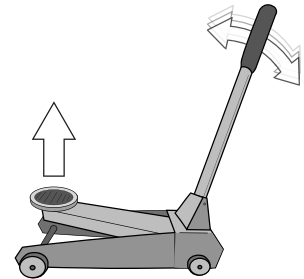


Figure 204. Use a jack or the equivalent to lift up the wheelchair.

3. Use the blocks to secure the chair further.

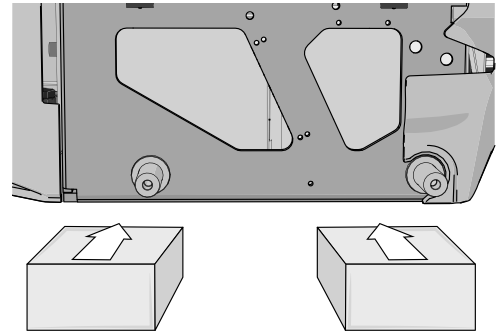


Figure 205. Use two blocks on each side of the chassis. The wheels have been removed in this figure for a better view.

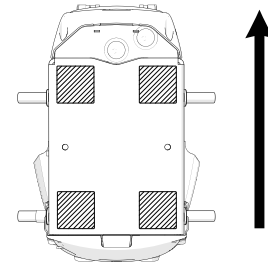


Figure 206. Block location. The arrow shows the direction of travel.

4. Remove the hub cap (the design may vary depending on markets and market regulations) by carefully levering it out using fingers on two edges of the hub cap.

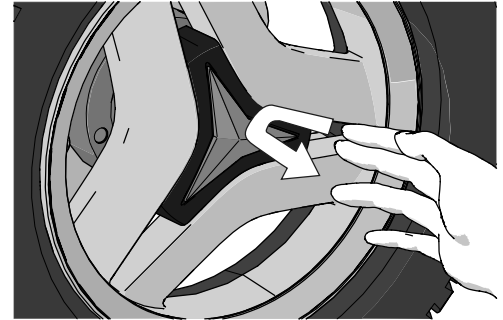


Figure 207. Use your fingers as follows on two edges of the hub cap.

5. Remove the three screws that hold the wheel in place. The central screw must not be removed.
6. Remove the wheel by pulling it straight out.
7. Remove the spacer (only on some models).

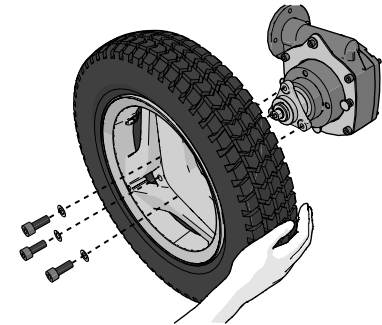


Figure 208. Pull the wheel straight out after you have removed the three screws.

5.6.1.2 Installing drive wheels

1. Fit the spacer (only on some models).
2. Fit the wheel onto the wheel hub.
3. Insert the three screws and the three washers. Tighten the screws no more than 15 Nm.
4. When all screws and washers are in place, tighten the screws. Tightening torque 24 Nm.

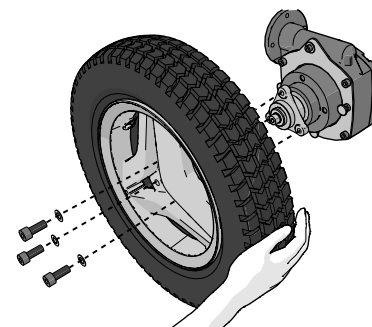


Figure 209. Fit the wheel onto the wheel hub.

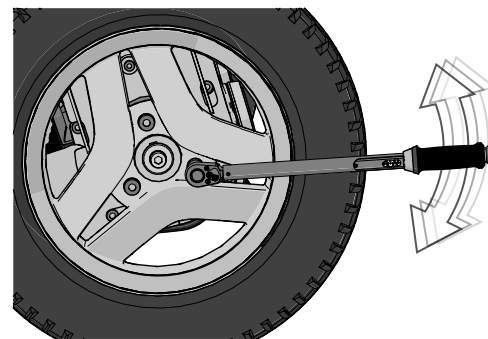


Figure 210. Use a torque wrench to tighten the screws.

5. Push the hub cap (the design may vary depending on markets and market regulations) in place.
6. Remove the blocks.
7. Lower the wheelchair using a jack or equivalent.

5.6.1.3 Drive wheel rim

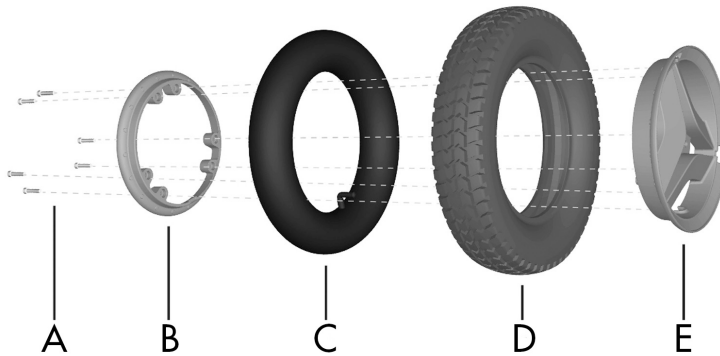


Figure 212. Fitting a pneumatic tyre to a split rim.

- A.** Screw, ISO 4762 M6x25 8.8 Fe/Zn 5 C1/TUF-LOK DIN 267-28.
- B.** Rim, inner section.
- C.** Inner tube (only on pneumatic tyres).
- D.** Tyre.
- E.** Rim, outer section.

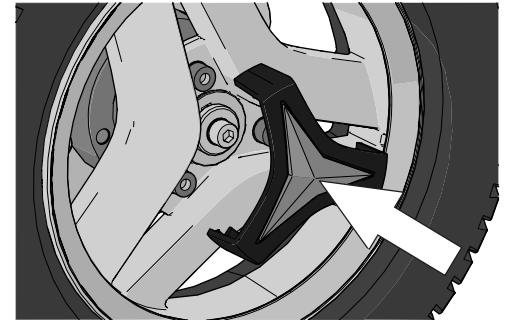


Figure 211. The hub cap snaps when it is in place.

5.6.1.4 Taking the drive wheel rim apart



WARNING!

Risk of injury - release air from tyre

Before taking the wheel rim apart, release air from the pneumatic tyre. Failure to do so may cause damage to the tyre, rim and/or bodily injury.

The rim can be taken apart to allow fitting or removal of solid or pneumatic tyres.

1. Remove the wheel from the wheelchair. See 5.6.1 *Drive wheels*, Page 240.
2. If the tyre is pneumatic, release the air.
3. Remove the six screws holding the two halves of the rim together.
4. Take the rim apart.

5.6.1.5 Assembling the drive wheel rim

- i** Read all warnings contained in this section before filling the tyres. Failure to do so may result in injury to the user and damage to the wheelchair and other property and also void any guarantee applicable to the wheelchair.

Assemble in the reverse order. Tighten the six screws using a torque wrench. Tightening torque: 22 Nm. Inflate the tyre to the recommended tyre pressure: 200–250 kPa (2–2.5 bar).



CAUTION!

Risk of injury if tyre pressure is incorrect

Before operating the wheelchair for the first time and regularly thereafter, check that the tyre pressure meets the specifications in this manual. Check the tyre pressure when the wheelchair experiences a significant change in temperature or altitude. Incorrect tyre pressure may cause the wheelchair to be less stable, less manoeuvrable and cause damage to the wheelchair and/or bodily injury.

**NOTICE****Risk of damage if tyres are overfilled**

Do not overfill the tyres. Overfilling may result in damage to the wheel assembly.

**NOTICE****Risk of reduced performance when tyre pressure is insufficient**

Insufficient tyre pressure may result in abnormal wear and a shorter driving range.

**CAUTION!****Maintenance by a qualified service technician**

Only qualified service technicians should perform the maintenance and repair specified in this manual. Read all instructions carefully before proceeding. If any questions arise, contact Permobil for assistance.

5.6.2 Inflating tyres

i Read all warnings contained in this section before filling the tyres. Failure to do so may result in injury to the user and damage to the wheelchair and other property and also void any guarantee applicable to the wheelchair.

i Applies only if the wheelchair is fitted with pneumatic tyres.

At regular intervals, check that the wheelchair's tyres have the prescribed pressure between 200–250 kPa (2–2.5 bar). Incorrect tyre pressure can impair stability and manoeuvrability, while extremely low tyre pressure can cause abnormal wear as well as shorter tyre life.

1. Unscrew and remove the plastic valve cap on the tyre air valve.
2. Connect the compressed air nozzle to the valve and adjust the tyre pressure to the prescribed level.
3. Install the plastic valve cap.



Figure 213. Filling valve on drive wheel.

**CAUTION!****Risk of injury if tyre pressure is incorrect**

Before operating the wheelchair for the first time and regularly thereafter, check that the tyre pressure meets the specifications in this manual. Check the tyre pressure when the wheelchair experiences a significant change in temperature or altitude. Incorrect tyre pressure may cause the wheelchair to be less stable, less manoeuvrable and cause damage to the wheelchair and/or bodily injury.

**NOTICE****Risk of damage if tyres are overfilled**

Do not overfill the tyres. Overfilling may result in damage to the wheel assembly.

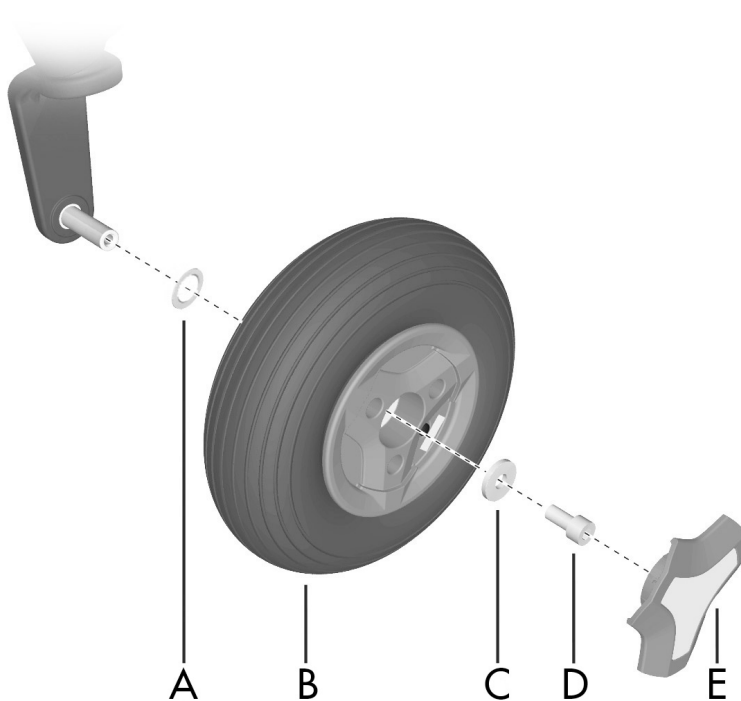
**NOTICE****Risk of reduced performance when tyre pressure is insufficient**

Insufficient tyre pressure may result in abnormal wear and a shorter driving range.

**CAUTION!****Maintenance by a qualified service technician**

Only qualified service technicians should perform the maintenance and repair specified in this manual. Read all instructions carefully before proceeding. If any questions arise, contact Permobil for assistance.

5.6.3 Castor wheels



A. Spacer.

B. Installing castor wheels

Wheel.

C. Washer, 8.5x23x3.

D. Screw, ISO 4762 M8x16 10.9 Fe/Zn/
TUF-LOK.

E. Hub cap (the design may vary depending
on markets and market regulations).

Figure 214. Assembling the rim.

The following tools are necessary for this task:

- 1 Torque wrench.
- 1 Allen key socket, 6 mm.
- 1 Jack.
- 4 Blocks for securing the wheelchair.

5.6.3.1 Removing castor wheels

1. Switch off the main power switch on the control panel.
2. Jack up the wheelchair until the wheel turns freely.

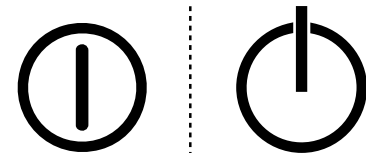


Figure 215. On/Off symbol depending on model.

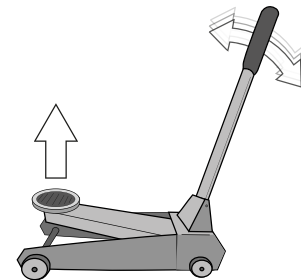


Figure 216. Use a jack or the equivalent to lift up the wheelchair.

3. Use the blocks to secure the chair further.

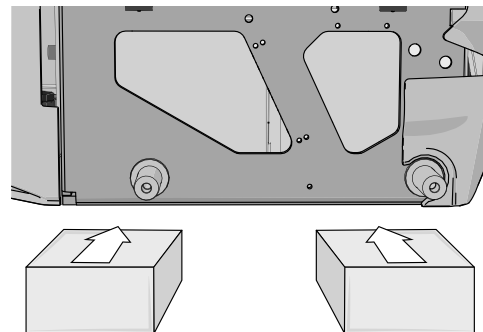


Figure 217. Use two blocks on each side of the chassis. The wheels have been removed in this figure for a better view.

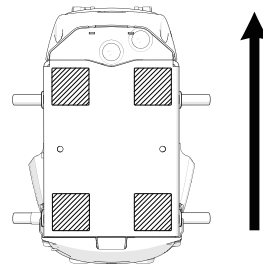


Figure 218. Block location. The arrow shows the direction of travel.

4. Remove the hub cap (E) by carefully prying it out using a screw driver.
5. Remove the screw (D) and the washer (C).
6. Pull the wheel off the axis.

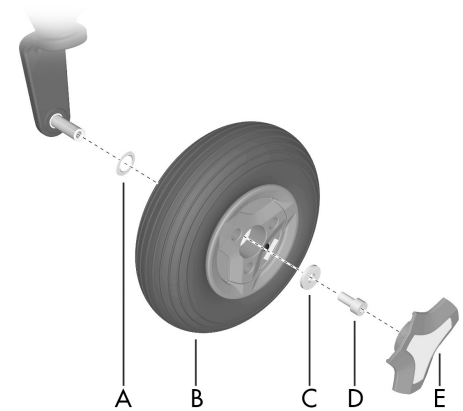


Figure 219. Assembling the rim.

5.6.3.2 Installing castor wheels



NOTICE

Replace used wheel screw

If a wheel screw is removed for tyre service, replace it with a new, unused screw from Permobil and tighten it to the recommended torque. Also, inspect the drive axle and wheel rim for any damage. Damage to either part can cause the wheel bolt to loosen or fracture. Because the TUF-LOK thread lock fluid wears off, Permobil recommends that wheel screws only be used once.

1. Check that the wheel axis and rim are undamaged. Clean to remove dirt and rust. Replace damaged parts.
2. Fit the spacer (A) on the axle.
3. Install the wheel (B) on the axle by hand without using any tools. Make sure the rim is fully seated on the axle.
4. Use the screw (D) and washer (C) to install the wheel (B); do so by hand without using any tools.
5. Tighten the screw (D) using a torque wrench. Tightening torque: 24 Nm. Do not use a pneumatic impact wrench.
6. If the tyre is pneumatic, fill it to the recommended pressure. See 5.6.4 *Inflating castor wheels*, Page 262.
7. Fit hub cap (E).
8. Remove the blocks.
9. Lower the wheelchair using the jack.

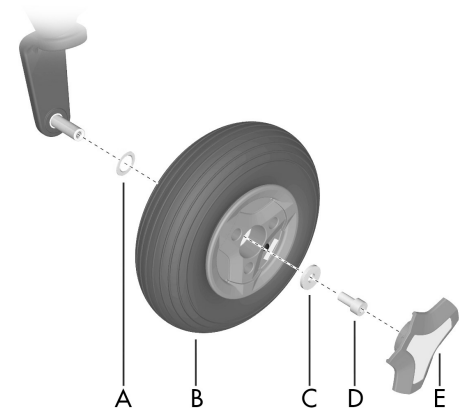


Figure 220. Assembling the rim.

5.6.3.3 Taking the castor wheel rim apart

1. Remove the castor wheel from the wheel fork. See 5.6.3.1 *Removing castor wheels*, Page 255.
2. If the tyre is pneumatic, release the air.
3. Remove the three bolts with nuts that hold the inner and outer parts of the rim together.
4. Take the rim apart.

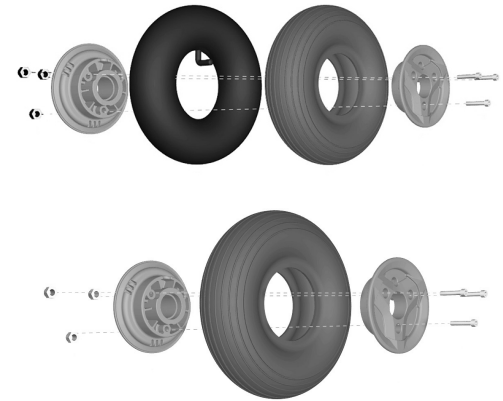


Figure 221 . Rim.

5.6.3.4 Putting the castor wheel together

1. Fit the two rim halves together with the tyre.
2. Tighten the three screws using a torque wrench.
Tightening torque: 9.8 Nm.
3. Fit the wheel onto the wheelchair. See
5.6.3.2 *Installing castor wheels*, Page 258.
4. Remove the blocks.
5. Lower the wheelchair with the jack or the equivalent.

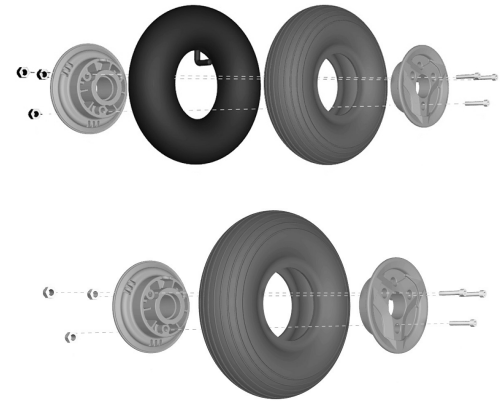


Figure 222. Rim.

5.6.4 Inflating castor wheels

- i** Applies only if the wheelchair is fitted with pneumatic castor wheel tyres.
- i** Read all warnings contained in this section before filling the tyres. Failure to do so may result in injury to the user and damage to the wheelchair and other property and also void any guarantee applicable to the wheelchair.

At regular intervals, check that the wheelchair's tyres have the prescribed pressure. Incorrect tyre pressure can impair stability and manoeuvrability, while extremely low tyre pressure can cause abnormal wear as well as shorter tyre life. Accordingly, check regularly to ensure tyre pressure is maintained at 200–250 kPa (2–2.5 bar). You need the valve adapter from the wheelchair's tool bag to inflate the castor wheel tyres.

1. Unscrew and remove the valve cap on the tyre valve.
2. Attach the valve adapter to the tyre valve.
3. Connect the compressed air nozzle to the valve and adjust the tyre pressure to the correct level.
4. Put the valve adapter back into the tool bag and put the valve cap back when the castor wheel tyres are inflated.



Figure 223. Filling valve.

**CAUTION!****Risk of injury if tyre pressure is incorrect**

Before operating the wheelchair for the first time and regularly thereafter, check that the tyre pressure meets the specifications in this manual. Check the tyre pressure when the wheelchair experiences a significant change in temperature or altitude. Incorrect tyre pressure may cause the wheelchair to be less stable, less manoeuvrable and cause damage to the wheelchair and/or bodily injury.

**NOTICE****Risk of damage if tyres are overfilled**

Do not overfill the tyres. Overfilling may result in damage to the wheel assembly.

**NOTICE****Risk of reduced performance when tyre pressure is insufficient**

Insufficient tyre pressure may result in abnormal wear and a shorter driving range.



CAUTION!

Maintenance by a qualified service technician

Only qualified service technicians should perform the maintenance and repair specified in this manual. Read all instructions carefully before proceeding. If any questions arise, contact Permobil for assistance.

5.7 Main circuit breaker

The main circuit breaker also functions as a battery isolator although it is referred to as the main circuit breaker in the user manual.

The main circuit breaker is automatic and can be reset when it has tripped. Reset it by putting the switch to the On position.



NOTICE

Investigate tripped main circuit breaker

A tripped main circuit breaker often indicates a major electrical fault. The cause of a tripped main circuit breaker must be carefully investigated and determined before resetting the circuit breaker.



NOTICE

Before using the main circuit breaker

Always switch off the power to the control panel before switching off the main power with the main circuit breaker.

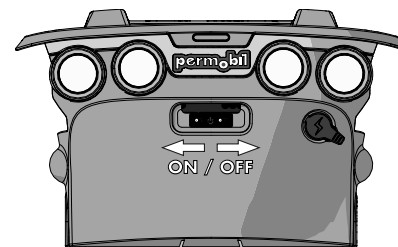


Figure 224. Main circuit breaker.

5.8 Brake release

Every month, check that the brake release and the brake release lever(s) are working properly.

When the brakes are released, it must not be possible to drive the wheelchair. If it can be driven, contact an authorised Permobil service centre as soon as possible.

5.9 Positioning belt

(i) Accessory

Check the condition of positioning belts regularly in case any damage or wear has occurred. If signs of damage or wear appear, replace the positioning belt immediately through your Permobil dealer.

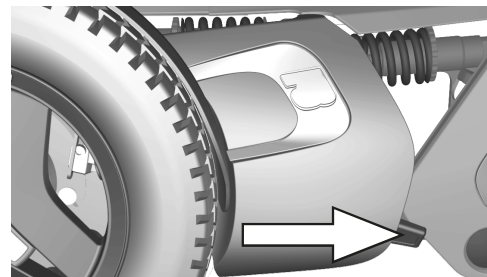


Figure 225. Brake release lever.

5.10 Serial number labels

5.10.1 Serial number label on chassis

The serial number label is located on the lower, left-hand side of the wheelchair chassis. Look between the rim spokes.

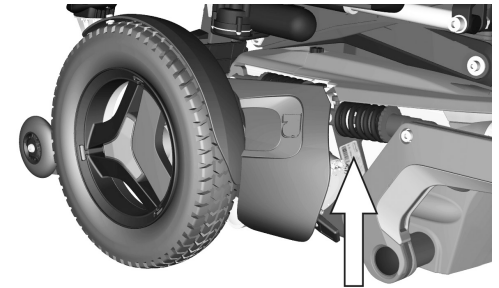


Figure 226. Chassis identification number label.

5.10.1.1 Serial number label description

1. Made in (country of final assembly) by (address of site of final assembly).
2. Serial number.
3. Product type.
4. Date of assembly.
5. EAN code.
6. Maximum user weight.

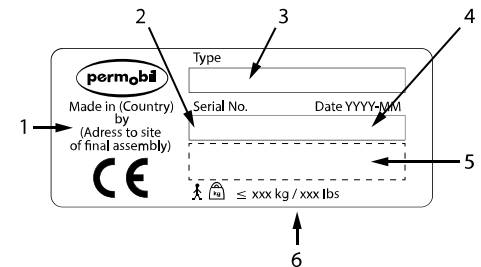


Figure 227. Serial number label.

5.10.2 Serial number label R-net power module



Figure 228. Power module ID number.

5.10.3 Serial number label on the control panel

The serial number label is only visible when the panel is removed from the panel holder.



Figure 229. Control panel ID number.

6 Approved locking systems

- Dahl Docking System MKII

7 Restrictions and limitations

7.1	Support wheels	272
7.1.1	Support wheels, restrictions	272
7.1.2	Wheelchairs with support wheels	272
7.1.3	Wheelchairs without support wheels	273
7.2	Speed restriction conditions	274
7.3	Conditions that limit seat movement	275
7.3.1	Actuator end limits excluded	275

7.1 Support wheels

7.1.1 Support wheels, restrictions

The wheelchair is available in different configurations with and without support wheels. The purpose of these wheels is to reduce the risk of tipping forward when travelling at higher speeds. The weight, speed and stability information below will help achieve the right configuration for the user.



CAUTION!

Tip risk - do not remove support wheels

If it is determined that the user will require support wheels, they must remain fitted at all times.

7.1.2 Wheelchairs with support wheels

- Users weighing 100 kg or more must have support wheels and the support wheels must be positioned in the bottom position.
- Users weighing less than 100 kg, with max speed set to 9,5 km/h, must have support wheels and the support wheels should be mounted in the top position.

7.1.3 Wheelchairs without support wheels

- Users must weigh less than 100 kg.
- Max speed is limited to 8 km/h.

7.2 Speed restriction conditions

Speed restriction	When	or when	or when	or when
Low speed	Seat elevated 50 - 150 mm	Back angle $\geq 150^\circ$ or $< 90^\circ$	Tilt angle $-6^\circ - -10^\circ$	Leg support angle $> 150^\circ$ (angle to seat plate)
Extra low speed	Seat elevated > 150 mm	Tilt angle $-10^\circ - -20^\circ$	Tilt angle $-6^\circ - -10^\circ$ and leg support angle $> 150^\circ$ (to seat plate)	Tilt angle $-6^\circ - -10^\circ$ and seat elevated > 50 mm
Drive inhibit	Tilt angle $-21^\circ - -45^\circ$	Powered transfer footplates hit ground	Tilt angle $-10^\circ - -20^\circ$ and leg support angle $> 150^\circ$ (to seat plate)	Tilt angle $-10^\circ - -20^\circ$ and seat elevated > 50 mm

7.3 Conditions that limit seat movement

7.3.1 Actuator end limits excluded

Conditions > Function	When	or when	or when
Seat lift stopped	Tilt back angle >130° and rear of seat raised less than 120 mm when user weight 100 kg	-	-
Tilt backward stopped	Tilt back angle ≥180° *)	-	-
Tilt forward stopped (anterior tilt is when tilt <0°)	Tilt back angle >130° and rear of seat raised less than 120 mm when user weight 100 kg	Tilt back angle ≤85° *)	When tilt ≤ 0° unless Tone, Reach or Transfer option

Conditions > Function	When	or when	or when
Recline stopped	Tilt back angle $\geq 180^\circ$	Tilt back angle $\leq 85^\circ$	-
Leg support stopped	Total leg support angle $\leq 93^\circ$ when anterior tilt $> -10^\circ$	Total leg support angle \leq 98° when anterior tilt $< -10^\circ$	-

Observe ★) Tilt or anterior tilt may continue if 'pushed backrest' is selected.

8 Troubleshooting

8.1	Troubleshooting guide.....	278
8.2	Diagnostics R-net LCD control panel	279
8.2.1	General.....	279
8.2.2	Diagnostic screens	280
8.2.3	Example of a screen showing a system fault	282
8.3	Diagnostics R-net LED control panel	283
8.3.1	Battery voltage indicator	283
8.3.2	Steady	283
8.3.3	Slowly flashing red LEDs, 1–2 LEDs.....	284
8.3.4	Rapidly flashing, 1–10 LEDs	284
8.3.5	Example of error messages and remedies	286
8.4	Repairing defective units	288

8.1 Troubleshooting guide

The following troubleshooting guide describes a number of faults and events which may occur when you use the wheelchair, together with suggested remedies. Note that the guide cannot describe all the problems and events which may occur and you should always contact your service provider or Permobil in case of doubt.

Event	Possible cause	Remedy
The wheelchair does not start.	Batteries discharged.	Charge the batteries.
	The cable connection to the control panel has come loose.	Insert the cable in the control panel.
	Main circuit breaker switched to off position after e.g. battery replacement.	Reset the main circuit breaker. See page 265.
	Main circuit breaker tripped.	See page 265.
The wheelchair cannot be driven.	Battery charger connected.	Stop charging. Disconnect the charging cable from the wheelchair charger socket.
	Brake release activated.	Reset the brake release.
	Wheelchair locked.	Unlock the wheelchair.
The wheelchair switches itself off after a certain period of inactivity (1 - 30 min).	The electronics' energy-saving mode has been activated.	Switch the wheelchair on again using the start button on the control panel.

Event	Possible cause	Remedy
The wheelchair stops while being driven.	The cable connection to the control panel has come loose.	Insert the cable in the control panel.
	Main circuit breaker tripped.	See page 265.
The wheelchair can only be driven at reduced speed.	Seat lift or seat tilt raised too high. Applies only to powered seat lift and seat angle.	Lower the seat lift or seat tilt.
The wheelchair cannot be charged.	Main circuit breaker switched to off position after e.g. battery replacement.	See page 265.
	The charging circuit breaker has tripped.	Wait five minutes, the circuit breaker will automatically reset.

8.2 Diagnostics R-net LCD control panel

8.2.1 General

When an error or a fault occurs in the wheelchair's electronics, information about it is displayed in the control panel display. This information can then be used to diagnose where the error, or fault, occurred and its cause.

Troubleshooting and repairs must always be performed by qualified personnel with good knowledge of the wheelchair's electronics.

8.2.2 Diagnostic screens

8.2.2.1 Current diagnostic screen

When the control system's integrated protection circuits have tripped so that the control system can no longer operate the wheelchair, a diagnostic screen is displayed in the control panel display.

This indicates a system fault, i.e. R-net has detected a problem somewhere in the wheelchair's power system.



NOTICE

The diagnostic screen displays error occasionally

If the fault is in a module not currently in use, it may still be possible to drive the wheelchair, but the diagnostic screen will display error occasionally.

Switch off the wheelchair and leave it switched off for a few minutes. Restart the wheelchair. If the fault persists, you must switch off the wheelchair and contact your service provider. Write down the information displayed in plain text in the control panel display and pass it on to your service provider.

Do not use the wheelchair until the problem has been remedied or you have received other instructions from your service provider.

**WARNING!****Performing diagnostics**

Diagnostics may only be performed by personnel with knowledge of the wheelchair's electronic control system. Incorrect or poorly performed repair work may make the wheelchair dangerous. Permobil accepts no liability for any personal injury or damage to the wheelchair and its surroundings that occur due to incorrect or poorly performed repairs.

**NOTICE****Unapproved replacement of parts**

If any part is replaced without approval from Permobil, the wheelchair guarantee will become invalid. Permobil accepts no liability for any loss that occurs as a result of a control system component being opened, adjusted or modified without permission.

8.2.3 Example of a screen showing a system fault

8.2.3.1 Identified module

The system fault indicator is displayed on the screen when the control system module has detected a problem. The codes below indicate where the problem is located.

PM = Power module

JSM = Joystick module

8.2.3.2 Error message

The error message displayed in the bottom left corner of the screen provides a brief description of the error type.

8.2.3.3 Error code

The four-digit code displayed in the bottom right corner of the screen indicates which protection circuit has tripped.



PM
Low Battery

2C00

Figure 230. Screen showing system fault indication.

8.3 Diagnostics R-net LED control panel

8.3.1 Battery voltage indicator

Each time the wheelchair is started, parts of its electronics are checked. When a fault occurs in these parts, it is displayed on the control panel battery voltage indicator and the indicator for speed or driving profile in the form of one or more flashing LEDs.

Troubleshooting and repairs must always be performed by qualified personnel with good knowledge of the wheelchair's electronics.



NOTICE

Error signals

Error messages are not displayed by indicators while the wheelchair is being driven. They appear when it is next started.

8.3.2 Steady

Everything is in order. The number of LEDs that light up depends on the charge remaining in the batteries. If the batteries are fully charged, all the LEDs light up.

8.3.3 Slowly flashing red LEDs, 1–2 LEDs

The batteries must be charged immediately.

8.3.4 Rapidly flashing, 1–10 LEDs

A fault has been detected in the wheelchair's electronics and the wheelchair must not be driven.

1. Switch off the wheelchair.
2. Check that all visible cables and the cable to the control panel are connected correctly.
3. Switch the wheelchair on again. If the fault persists, count the number of flashing LEDs and check for a possible cause and remedy in the following table.
4. Do not use the wheelchair until the problem has been remedied or you have received other information from your service provider.




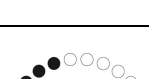
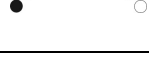


**WARNING!****Performing diagnostics**






Diagnostics may only be performed by personnel with knowledge of the wheelchair's electronic control system. Incorrect or poorly performed repair work may make the wheelchair dangerous. Permobil accepts no liability for any personal injury or damage to the wheelchair and its surroundings that occur due to incorrect or poorly performed repairs.

**NOTICE****Unapproved replacement of parts**

If any part is replaced without approval from Permobil, the wheelchair guarantee will become invalid. Permobil accepts no liability for any loss that occurs as a result of a control system component being opened, adjusted or modified without permission.

8.3.5 Example of error messages and remedies

Event	Indication	Remedy
1 LED Low battery voltage		Check the condition of the batteries. Check the contact between the battery and the control unit.
2 LEDs Failure in left drive motor		Check the connection of the left drive motor.
3 LEDs Short circuit in left drive motor		Check the left drive motor's contacts and cables.
4 LEDs Failure in right drive motor		Check the connection of the right drive motor.
5 LEDs Short circuit in right drive motor		Check the right drive motor's contacts and cables.
6 LEDs Battery charger connected		Disconnect the battery charger.
7 LEDs Joystick error		Check that the joystick has not been moved when starting the wheelchair.

Event	Indication	Remedy
8 LEDs Control system error		Check the contacts to the output stage.
9 LEDs Failure in brake circuit		Check the contacts to the magnetic brakes.
10 LEDs High battery voltage		Check the battery and the contacts between the battery and the output stage.
7+5 LEDs Communication error		A communication error has been detected. Check that the cable to the control panel is not damaged and is correctly inserted.
Actuator indicator Actuator error		An actuator error has been detected. Contact authorised service for help.

8.4 Repairing defective units

Apart from specific OEM-approved spare parts, there are no replaceable parts in the R-net control system. Contact Permobil for further information on OEM-approved spare parts. Defective units must be sent for repair to Permobil or an authorised Permobil service centre.

Index

- A**
- Accessories 125
 - Accessories, ordering 14
 - Admonitions, descriptions 18
 - Air transportation 215
 - Anterior tilt 49
 - Anterior tilt, seat control panel.... 121
 - Armrest angle 168
 - Armrest height 165
 - Armrest height and angle,
individual adjustment 169
 - Armrest rotation 164
 - Armrest, adjustment 164
- B**
- Backrest angle, powered 51
 - Backrest recline 55
 - Backrest recline, seat control
panel 120
 - Backrest, adjustment 161
 - Backrest, remove 161
 - Batteries 60
 - Batteries, charging 201, 239
 - Batteries, storage 239
 - Battery voltage indicator 114
 - Battery, replace 225
 - Bluetooth® mode 80
 - Brake release 187, 266
 - Buttons, ICS control panel 119
 - Buttons, R-net LCD 65
 - Buttons, R-net LED 111
- C**
- Castor wheels 262
 - Castor wheels, removal or
mount 255
 - Charging batteries 201, 239
 - Charging socket 62
 - Cleaning 223
 - Cleaning, ConnectMe 145
 - ConnectMe 127
 - Control panel R-net LED,
diagnostics 283
 - Control panel seat, ICS 117
 - Control panel, R-net LCD 64
 - Control panel, R-net LED 110
- D**
- Defective units, R-net control
system 288
 - Diagnostics R-net LCD control
panel 279
 - Diagnostics R-net LED control
panel 283
 - Display, R-net LCD 70
 - Documentation 15
 - Downhill, drive 197
 - Drive 185
 - Drive unit 58
 - Drive wheels, remove or
mount 240
 - Drive, joystick 191

Driving restrictions 193
 Driving technique 191

E

Emergency stop, R-net LCD..... 74
 Error message, R-net LED
 control panel 286
 Error, joystick 200

F

Flight mode, ConnectMe 140
 Footplate angle 174
 Footplate height 173
 Footplates, adjustment..... 173
 Footplates, powered transfer 122
 Footplates, seat control panel 122

G

General usage, ConnectMe 144
 General, drive 185
 Guarantee 12

H

Headrest, adjust 157
 Headrest, adjustment..... 155

I

Incident, reporting..... 14
 Inflating tyres 251
 Infrared mode 93
 IR control 93
 IR mode..... 93

J

Joystick error..... 200
 Joystick, drive..... 191

K

Knee support depth 176
 Knee support height 178
 Knee support width 177
 Knee support, adjustment..... 175

L

Labels 145, 267
 Leg length, power adjustable..... 121
 Leg support angle 56
 Leg support angle, powered..... 52
 Leg support angle, seat control
 panel..... 121
 Leg support length 172
 Leg support top cover 171
 Leg support, adjustment 170
 Lights 59
 Lock the control system, R-net
 LCD..... 103
 Lumbar support..... 162

M

Main circuit breaker..... 61
 Main circuit breaker, reset 265
 Maintenance and Service,
 ConnectMe..... 145
 Manual seat functions..... 54
 Move joystick 191

- O**
- Obstacles, driving over 195
- P**
- Paddle switches, R-net LCD 65
- Panel holder, adjustment 178
- Permobil headrest height and
depth adjustment 159
- Permobil headrest, angle
adjustment 160
- Permobil headrest, height
adjustment 158
- Permobil headrest, install 157
- Permobil headrest, remove 157
- Positioning belt 266
- Positioning belt, adjustment 183
- Power adjustable leg length 53
- Power adjustable leg length,
seat control panel 121
- Powered footplates, seat control
panel 122
- Powered seat functions 45
- Powered transfer footplates, seat
control panel 122
- Product approval, ConnectMe 136
- R**
- R-net control system, repair 288
- R-net LCD control panel,
diagnostics 279
- R-net LED control panel,
diagnostics 283
- Reflectors 59
- S**
- Scrapping and recycling 15
- Seat lift 120
- Seat lift, powered 47
- Seat tilt, powered 47
- Seat tilt, seat control panel 120
- Seat-to-floor function, seat
control panel 122
- Serial number label 267
- Serial number label,
ConnectMe 139
- Shock absorbers 58
- Side slopes, drive 196
- Slopes, drive 196
- Spare parts, ordering 14
- Storage, ConnectMe 145
- Support wheels, restrictions 190,
272
- T**
- Technical specifications,
ConnectMe 134
- Technical support 13
- Tool bag 222
- Transporting the wheelchair by
air 215
- Transporting the wheelchair by
rail 216
- Transporting the wheelchair by
vehicle 206
- Troubleshooting guide 278
- Trunk support 163

Turn off ConnectMe	144
Tyres, inflating	251

U

Unlock the control system, R- net LCD	103
Uphill, drive	199

W

Wheel locks	187, 266
Wheels	58
Wheels, castor	262
Wheels, inflating.....	251

www.permobil.com

permobil



334968 eng-UK