



Activity wheelchair with foldable frame suitable for teenagers and adults

Included in the base price:

- Straight or abducted frame
- Pneumatic or solid tyres
- Standard seat cover with storage bag
- Standard back cover
- Standard push handles (long)
- Standard knee lever brake
- Back tubes standard or reinforced

Delivery address / Company stamp		Billing address: <input type="checkbox"/> same as delivery address	
Name:		Name:	
Address:		Address:	

Quotation Order

Weight capacity: 120 kg
German aid index N°: 18.50.03.1084

Base price £2,429

Prices excl. VAT, valid from 01.03.2021

Ordering information:			
Reference/ internal description:		Date:	
Contact person:		Signature:	

Information For correct assembling, we need the following information from you:

1. Frame shape: straight **OR** abducted,
2. Frame version: standard frame height **OR** XL-frame height,
3. User measures (seat width, seat depth and back height)

Frame data	Sport frame standard height		Sport frame XL height	
	<input type="checkbox"/> Frame height = 210 mm N° 597594	£ 0	<input type="checkbox"/> XL-frame height = 250 mm N° 597595	£345
	Frame shape	Frame shape	Frame shape	Frame shape
	<input type="checkbox"/> straight N° 597496	£ 0	<input type="checkbox"/> straight N° 597496	£ 0
	<input type="checkbox"/> abducted 6 cm N° 597597	£210	<input type="checkbox"/> abducted 6 cm N° 597597	£210
User data	Seat width (N° 10..)		Seat width (N° 10..)	
Please note: At SD 34 and 36 cm only an internal mounting of the leg support is possible.	<input type="checkbox"/> 30 <input type="checkbox"/> 32 <input type="checkbox"/> 34	£ 0	<input type="checkbox"/> 38 <input type="checkbox"/> 40 <input type="checkbox"/> 42	£ 0
	<input type="checkbox"/> 36 <input type="checkbox"/> 38 <input type="checkbox"/> 40		<input type="checkbox"/> 44 <input type="checkbox"/> 46 <input type="checkbox"/> 48	
	<input type="checkbox"/> 42 <input type="checkbox"/> 44 <input type="checkbox"/> 46	£160	<input type="checkbox"/> 50	£ 0
	<input type="checkbox"/> 48 <input type="checkbox"/> 50			
	Seat depth (N° 11..)	Seat depth (N° 11..)	Seat depth (N° 11..)	Seat depth (N° 11..)
	<input type="checkbox"/> 34 <input type="checkbox"/> 36 <input type="checkbox"/> 38	£ 0	<input type="checkbox"/> 44 <input type="checkbox"/> 46 <input type="checkbox"/> 48	£ 0
	<input type="checkbox"/> 40 <input type="checkbox"/> 42 <input type="checkbox"/> 44		<input type="checkbox"/> 50 <input type="checkbox"/> 52 <input type="checkbox"/> 54	
	<input type="checkbox"/> 46 <input type="checkbox"/> 48 <input type="checkbox"/> 50			
	Back height (N° 12..)	Back height (N° 12..)	Back height (N° 12..)	Back height (N° 12..)
	back tube standard + 5 cm extension each	back tube reinforced + 5 cm extension each	back tube standard + 5 cm extension each	back tube reinforced + 5 cm extension each
	<input type="checkbox"/> 25 cm (...25)	<input type="checkbox"/> 25 cm (...253)	<input type="checkbox"/> 30 cm (...30)	<input type="checkbox"/> 30 cm (...302)
	<input type="checkbox"/> 30 cm (...30)	<input type="checkbox"/> 30 cm (...303)	<input type="checkbox"/> 35 cm (...35)	<input type="checkbox"/> 35 cm (...352)
	<input type="checkbox"/> 35 cm (...35)	<input type="checkbox"/> 35 cm (...353)	<input type="checkbox"/> 40 cm (...40)	<input type="checkbox"/> 40 cm (...402)
	<input type="checkbox"/> 40 cm (...40)	<input type="checkbox"/> 40 cm (...403)	<input type="checkbox"/> 45 cm (...45)	<input type="checkbox"/> 45 cm (...452)
		<input type="checkbox"/> 45 cm (...453)	<input type="checkbox"/> 50 cm (...50)	<input type="checkbox"/> 50 cm (...502)
		<input type="checkbox"/> 50 cm (...503)		
	£ 0	0,- €	£ 0	0,- €
		<i>recommended for increased pressure (e.g. Spasticity etc.).</i>		<i>recommended for increased pressure (e.g. Spasticity etc.).</i>
	<i>Back tubes can be moved vertically in 2.5 cm steps up to max. 5 cm. Not possible with tarta - back.</i>		<i>Back tubes can be moved vertically in 2.5 cm steps up to max. 5 cm. Not possible with tarta - back.</i>	

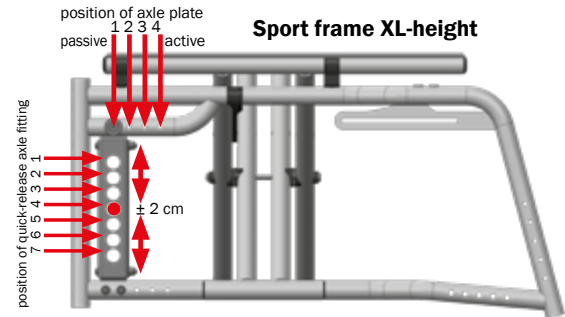
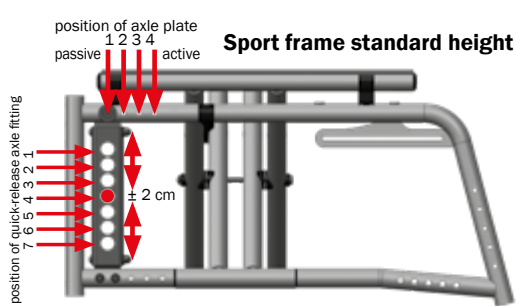

Measuring the lower leg length

Manufacturer data	User data	Retailer data	
Our data for the possible lower leg length are: The maximum or rather minimal possible distance between the top edge of the seat to the top edge of the foot plate MEASURED VERTICALLY (90°) .	You are measuring at the user: The distance between the hollow of the knee and the floor (=LLL) , measured at a vertical leg position of 90°	When ordering, please indicate TWO measures: <ul style="list-style-type: none"> • 1. the real LLL of the user AND • 2. the thickness of the cushion used by you 	

Example

Our data	Your data	We are assembling
In the order form, we are indicating e.g.: „possible distance from top edge seat to top edge foot plate at internal mounting of leg support = min. 3.5 up to max. 30 cm“.	The real lower leg length of the user amounts e.g.: „LLL = 31 cm“ ; The thickness of the cushion used by you amounts e.g.: „CT = 5 cm“.	Using your data, our technicians are calculating a distance of 26 cm between the top edge of the seat to the top edge of the foot plate. Therefore, the foot plate will be mounted to the position of 26 cm, measured vertically . <i>At a cushion thickness of only 3 cm, our technicians would mount the foot plate to a distance of 28 cm from the top edge of the seat to the top edge of the footplate instead.</i>





Seat system	
Seat cover	SeatFix



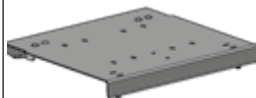
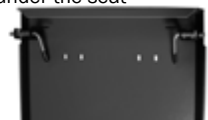

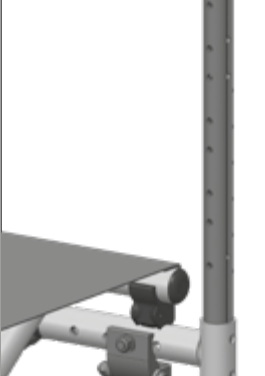
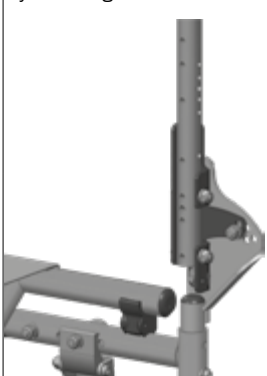
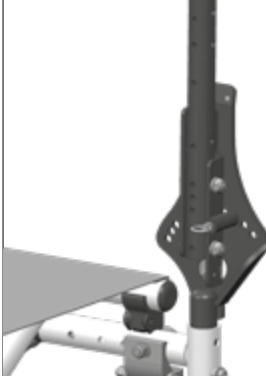
User measures for Sport frame Detailed table of sizes (seat heights front/back etc.) on p.16.				
For measuring the lower leg length please pay attention to the example on the left side			Degree of activity	Possible wheel sizes
Lower leg length (LLL)	Distance foot plate to seat standard frame	Seat height	Frame standard height	Recommendation in bold
Please indicate: Real lower leg length of the user: _____ cm Please indicate: Cushion thickness: _____ cm	Internal mounting of foot plate 4.5 cm - 32 cm External mounting of foot plate 31.5 cm - 48 cm Distance foot plate to seat at XL-frame Internal mounting of foot plate • 8.5 cm - 36 cm External mounting of foot plate • 35.5 cm - 52 cm	back: _____ cm front: _____ cm	Frame standard height Position of axle plate <input type="checkbox"/> 1 <input type="checkbox"/> 2 <input type="checkbox"/> 3 <input type="checkbox"/> 4 Position 1 = very passive Position 4 = very active Frame XL height Position of axle plate <input type="checkbox"/> 1 <input type="checkbox"/> 2 <input type="checkbox"/> 3 <input type="checkbox"/> 4 Position 1 = very passive Position 4 = very active	up to SD 46 cm 22"/24" wheel from SD 48 cm 24"/26" wheel

Colours		
Finish alternatives	Moderate metallic effect (except for Black & King's Blue)	Special colours (without additional charge, except for Nightblue)
<input type="checkbox"/> shiny £ 0 <input type="checkbox"/> matt (not possible with special colours!) N° 1561 £75	<input type="checkbox"/> Zinc Yellow (02) <input type="checkbox"/> Dark Green (15) <input type="checkbox"/> Pure Orange (21) <input type="checkbox"/> Crimson (04) <input type="checkbox"/> Pastel Blue (20) <input type="checkbox"/> Dark Blue (16) <input type="checkbox"/> Brilliant Blue (08) <input type="checkbox"/> Cream White (17) not metallic: <input type="checkbox"/> Girly Pink (19) <input type="checkbox"/> Black (31) <input type="checkbox"/> Chrome Yellow (06) <input type="checkbox"/> King's Blue (32)	Strong metallic effect: <input type="checkbox"/> Silver Metallic (36) <input type="checkbox"/> Anthracite Metallic (22) Coarse structured surface: <input type="checkbox"/> Coarse Black (27) Dormant colours: <input type="checkbox"/> Apple Green Dormant (18) <input type="checkbox"/> Fire Red Dormant (45) <input type="checkbox"/> Violet Dormant (50) Dormant col. with additional charge: <input type="checkbox"/> Nightblue Dormant (47) £65
Design package color anodization (Colour examples for anodized colours can be found on our website in the area equipment)		
<input type="checkbox"/> anodized Blue (01) <input type="checkbox"/> anodized Red (02) <input type="checkbox"/> anodized Green (03) <input type="checkbox"/> anodized Gold Orange (04) <input type="checkbox"/> anodized Violet (05) N° 1571.. £250	The following parts are anodized: Assembly group caster (fork, caps, adapter, half shells, wheel spacer), hand rims The design package ist only possible in the listed setting.	Restrictions: The hand rims are only available in the design package anodized colours by choosing aluminum hand rims. (not possible with stainless steel, Maxgrepp, PVC, double, nob or ergonomic hand rims. Also not possible with profile wheels)

Frame extension by 4 cm backwards	
Shifting of the center of gravity	Frame construction for seat shells
Frame extension by 4 cm backwards for the adjustment of a VERY ACTIVE center of gravity. The complete seat moves backwards by 4 cm. <input type="checkbox"/> incl. frame extension by 4 cm backwards incl. shifting of the back tubes by 4 cm backwards incl. shifting of the seat plate (SeatFix) by 4 cm backwards at constant seat depth Please indicate the actual seat depth of the user in the field „seat depth“. Equipment SeatFix (N°1926) only possible from SD 36.	Frame extension by 4 cm backwards for the installation of a seat shell. With this, you can compensate the installation depth of a seat shell back. <input type="checkbox"/> without nylon seat cover without back cover incl. stabilizer bar incl. extension of the frame by 4 cm backwards incl. shifting of the seat tubes by 4 cm backwards In the field „seat depth“ please indicate the sum of: SD user PLUS installation depth of the seat shell back! e.g.: seat depth user = 34 cm install. depth back of seat shell = 12 cm your seat depth specification = 46 cm
N° 597498 £82	N° 597499 £50

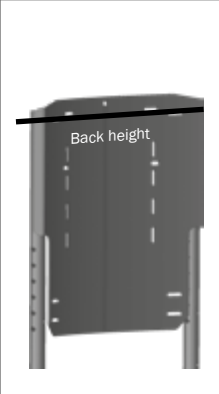
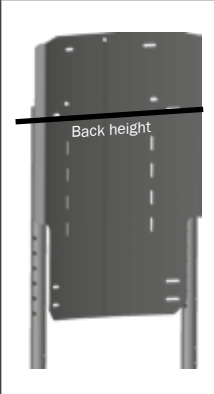
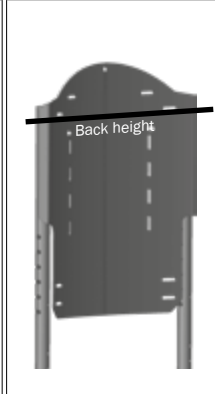
Seat		Seat extension		SeatFix Lock
Nylon seat cover	SeatFix	for nylon seat cover	for SeatFix	
with storage bag Colours: <input type="checkbox"/> black <input type="checkbox"/> red <input type="checkbox"/> blue <input type="checkbox"/> grey	<input type="checkbox"/> Firm aluminium seat plate, plugged and removable 	<input type="checkbox"/> Conversion set for nylon seat cover, growable up to 4 cm	<input type="checkbox"/> Seat extension for SeatFix, steplessly growable up to 4 cm	<input type="checkbox"/> Locking device for SeatFix, double-sided mounting under the seat 
N° 1914 0,- €	N° 1926 155,- €	N° 191407 95,- €	N° 191107 110,- €	N° 192021 196,- €/P

Back angle				Cover
			Gas pressure spring	
Back angle standard 90° 	Back angle firmly adjustable by screwing 	Back angle adjustable by raster 		Standard cover  Adjustable cover 

Curved back plate			Retractable back extension		Tarta® back system
Model 1	Model 2	Model 3			Example Tarta® back rest
 Back height	 Back height	 Back height			 Tarta® is an ergonomic back rest that offers best solutions in terms of adaptability. With the SORG adaptation holder you can adapt a Tarta® back rest easily. Tarta back rest is not included! Order information for Tarta® back systems at www.tartadesign.it/en/distributori/
Straight upper edge, 2 cm higher than back height	Straight upper edge, 10 or 20 cm higher than back height	Curved upper edge, 5, 10 or 15 cm higher than back height			

Back unit					
Back angle			Back cover		
<input type="checkbox"/> Standard back angle 90°, back tubes adjustable in height (max. 5 cm), screwed into the frame tube.	<input type="checkbox"/> Back angle firmly adjustable with screwing from 80°-105°, incl. stabilizer bar	<input type="checkbox"/> Back angle steplessly adjustable by 30° with gas pressure device, incl. stabilizer bar (from BH 35).	Standard cover <input type="checkbox"/> black <input type="checkbox"/> red <input type="checkbox"/> blue <input type="checkbox"/> grey	<input type="checkbox"/> Adjustable cover with strap system, incl. back cushion (thickness 2 cm) Breathable cover (choice of cover colour on page 7).	
N° 6237 £ 0	N° 6231 £145	<i>Extendable push handles and anti tipper required!</i> <i>Not with N° 597498 (shifting of the gravity center).</i> <i>Not approved for transport in a disabled person transport vehicle!</i> <i>Not with standard back cover N° 6710.</i> <i>Desk side guards and long side guards are not detachable or swiveling outwards.</i>	Not in combination with Back angle N° 6107		
<input type="checkbox"/> Stabilizer bar For stabilization when using a back cover	<input type="checkbox"/> Back angle adjustable with raster and completely stowable, incl. stabilizer bar				
N° 6400 £96	N° 6109 £245	N° 6107 £459	N° 6710 £ 0	N° 6701.. £200	

Curved back plate					
Model 1		Model 2		Model 3	
Firm curved back plate, BH+2 cm; cavity: <input type="checkbox"/> 15 mm (...015) <input type="checkbox"/> 30 mm (...030) <input type="checkbox"/> 50 mm (...050)		Firm curved back plate, BH+10 cm; cavity: <input type="checkbox"/> 15 mm (...115) <input type="checkbox"/> 30 mm (...130) <input type="checkbox"/> 50 mm (...150)		Firm curved back plate, BH+20 cm; cavity: <input type="checkbox"/> 15 mm (...215) <input type="checkbox"/> 30 mm (...230) <input type="checkbox"/> 50 mm (...250)	
				Firm curved back plate, BH+5 cm; cavity: <input type="checkbox"/> 15 mm (...315) <input type="checkbox"/> BH+10 cm; cavity: <input type="checkbox"/> 15 mm (...415) <input type="checkbox"/> 30 mm (...330) <input type="checkbox"/> 30 mm (...430) <input type="checkbox"/> 50 mm (...350) <input type="checkbox"/> 50 mm (...450)	
N° 693.. £279		N° 693.. £355		N° 693.. £355	

Retractable back extension	Adaptation holder for
Tarta® back system	
<input type="checkbox"/> back extension up to 17.5 cm, with detachable head pad; weight saving in comparison to a head rest approximately 1000 g -Only in combination with curved back plate, not possible with head rest (N° 6861..) and foil for curved back plate (N° 2527). -Unsuitable as a headrest for the transport of a disabled person in a passenger vehicle! -Restrictions in combination with curved back plate: Model 1: from BH 35 cm / curve depth 50 mm only from SW30 Model 2: Not possible Model 3: from BH 35 cm / curve depth 50 mm only from SW30; only with BH+5 cm	Holder for Tarta back system incl. Tarta back tubes <input type="checkbox"/> for back angle adjustable with raster (N° 6109) <input type="checkbox"/> for standard back angle (N° 6237) -Only in combination with stabilizer bar N° 6400 -back height can't be selected when Tarta back system is selected -Not possible with back angle with screwing / curved back plate, back cover / back angle with gas pressure device -Not permitted when using the wheelchair as a seat for transportation in the car! -Tarta back is NOT included! -Order information for Tarta back system and instructions at www.tartadesign.it/en/distributor/
N° 686069 £260	N° 611705 £189

 To see the latest versions of our order forms, please visit www.sorgrollstuhltechnik.de/download-portal

Side guards				
Standard side guard	Clothes guard	Desk side guard with arm rest	Desk side guard with raster arm rest	Long side guard with long arm rest

Desk side guard foldable backwards, inward swivelling and detachable		

Leg support for Sport frame, firmly integrated into the frame, with foot plate(s)				
Model 1	Model 2	Model 3	Model 4	Model 5
		<p>ATTENTION: not suitable for patients with spasticity</p>	<p>ATTENTION: not suitable for patients with spasticity</p>	

Seat cushion (all covers with zippers and changeable)				
	Standard cushion	Anatomical cushion	Cover design	Incontinence cover
<input type="checkbox"/> No seat cushion (please tick if no cushion is required)	Synthetic foam for firm and comfortable seating <input type="checkbox"/> 3 cm (...03) <input type="checkbox"/> 5 cm (...05)	<input type="checkbox"/> Anatomically formed, with slight abduction, changeable cover (Thickness of the front upholstery, depending on cushion size, is 5-6 cm)	The colour of the chosen covers can be selected below. -> choice of Trevira cover colour	<input type="checkbox"/> For standard cushion as configured on the left
<input type="checkbox"/> Seat cushion WITHOUT COVER				
N° 998001 £30	N° 80.. £90	N° 891002 £419		N° 86.. £89
ADDITIONAL COVERS for cushions as configured <input type="checkbox"/> 1 cover (...01) <input type="checkbox"/> 2 cover (...02)	Pressure relief cushion for medium-soft seating <input type="checkbox"/> 3 cm (...03) <input type="checkbox"/> 5 cm (...05)	<input type="checkbox"/> ADDITIONAL COVER for anatomical cushion as configured		<input type="checkbox"/> For anatomical cushion as configured on the left
N° 82.. £75/pcs	N° 81.. £119	N° 891003 £166	N° 80..	N° 891004 £166

Back cushion (all covers with zippers and changeable)				
	Standard cushion	Standard cushion	Anat. back cushion	Cover design
<input type="checkbox"/> No back cushion (please tick if no cushion is required)	<input type="checkbox"/> Standard cushion for curved back plate , 3 cm thick, with zipper, breathable cover (choice of cover colour below).	<input type="checkbox"/> Standard cushion for back cover , 3 cm thick, with zipper and straps, (choice of cover colour below).	Anatomically formed, incl. changeable cover (choice of cover colour below) cavity: <input type="checkbox"/> 3 cm (...04) <input type="checkbox"/> 5 cm (...06) Not possible with back cover N° 6701.. & N° 6710 Customized product	The colour of the chosen covers can be selected below. -> choice of Trevira cover colour
<input type="checkbox"/> Back cushion WITHOUT COVER				
N° 998501 £30			N° 8911.. £245	
ADDITIONAL COVERS for cushions as configured <input type="checkbox"/> 1 cover (...01) <input type="checkbox"/> 2 covers (...02)			<input type="checkbox"/> ADDITIONAL COVER for anatomical back cushion as configured	
N° 85.. £75/pcs	N° 8517 £139	N° 8514 £118	N° 891110 £135	N° 85..

Choice of Trevira cover colour <small>Note: Color views may differ from reality depending on the screen view / printout and are only for initial orientation.</small>								
Please choose your colour of the selected covers:								
<input type="checkbox"/> black (30)	<input type="checkbox"/> grey (31)	<input type="checkbox"/> nightblue (32)	<input type="checkbox"/> ultramarine blue (33)	<input type="checkbox"/> petrol (34)	<input type="checkbox"/> applegreen (35)	<input type="checkbox"/> burgundy (36)	<input type="checkbox"/> red (37)	<input type="checkbox"/> pink (38)
N° 80.. (seat cushion/anat. cushion) /			N° 85.. (back cushion/anat. back cushion) /		N° 6701.. (adjustable back cover)			

Side guards and arm rests			
Standard	Clothes guard	Desk side guard	Long side guard
<input type="checkbox"/> Corrugated aluminium, screwed, adjustable in height <i>incl. insulation protection pads</i>	<input type="checkbox"/> Corrugated aluminium, screwed, adjustable in height, with synthetic clothes guard <i>incl. insulation protection pads</i>	<input type="checkbox"/> for driving under tables etc., foldable backwards, inward swivelling and detachable, aluminium From Back height 30cm	<input type="checkbox"/> Foldable backwards, swingable backwards and detachable, aluminium From Back height 30cm
N° 4525 £ 0	N° 5024 £139	N° 4610 £149	N° 4611 £149
Arm rest	Clothes guard	Raster arm rest	Long arm rest
<input type="checkbox"/> with pad, 24 cm long, screwed, adjustable in height. Suitable for all side guards (except for long side guard)	<input type="checkbox"/> Clothes guard, black, for desk side guard, screwed Only for N° 4610, not with arm rests	<input type="checkbox"/> with pad, 24 cm long, with raster adjustable in height. Only suitable for desk side guard and long side guard	<input type="checkbox"/> with pad, 37 cm long, screwed, adjustable in height. Only suitable for long side guard N° 4611
N° 452600 £180	N° 461001 £110	N° 452506 £180	N° 452507 £180

To see the latest versions of our order forms, please visit www.sorgrollstuhltechnik.de/download-portal

Push handles				
Standard		Extendable		Push bar
short handle (5 cm)	long handle (11 cm)	short handle (5 cm)	long handle (11 cm)	foldable

Brakes			
Knee lever brakes	Bowden cable brake	Recoil blocking	Single-hand brake
<p>Standard lockable Pull to Lock</p>			

Brake lever extension		
Cover	Ball knob	Golf ball knob

Wheels				
Standard wheel	Profile wheel	Lightweight wheel	Double handrim	Distance double handrim

Leg support with foot rest for Sport frame Standard and XL height (adjustable in height, depth and angle)				
Model 1 undivided	Model 2 undivided	Model 3 divided	Model 4 divided	Model 5 turnable
<input type="checkbox"/> Internal mounting , undivided foot rest, hinged side-wards Distance 'Seat/Foot rest' measured WITHOUT SEAT CUSHION : • Standard height 4.5-32 cm • XL height 8.5-36 cm	<input type="checkbox"/> External mounting , undivided foot rest, hinged side-wards Distance 'Seat/Foot rest' measured WITHOUT SEAT CUSHION : • Standard height 31.5-48 cm • XL height 35.5-52 cm	<input type="checkbox"/> Internal mounting , divided foot rest, hinged side-wards Straight frame from SW 30 cm Distance 'Seat/Foot rest' measured WITHOUT SEAT CUSHION : • Standard height 4.5-32 cm • XL height 8.5-36 cm	<input type="checkbox"/> External mounting , divided foot rest, hinged side-wards Distance 'Seat/Foot rest' measured WITHOUT SEAT CUSHION : • Standard height 31.5-48 cm • XL height 35.5-52 cm	<input type="checkbox"/> similar to model 2 , additionally turnable outwards Distance 'Seat/Foot rest' measured WITHOUT SEAT CUSHION : • Standard height 31.5-48 cm • XL height 35.5-52 cm
N° 403601 £ 0	N° 403610 £ 0	N° 403602 £155	N° 403612 £155	N° 403611 £210

Leg support options	
Heel cups	Locking mechanism
for self-assembly, black <input type="checkbox"/> Size 1 (7 x 11,5 cm) (...01) <input type="checkbox"/> Size 2 (9 x 12,5 cm) (...02) <input type="checkbox"/> Size 3 (10 x 15,5 cm) (...03)	<input type="checkbox"/> Locking mechanism for leg support models with undivided foot rest
N° 4020.. £50	N° 403910 £69





Push handles		
Standard push handles	Extendable push handles	Push bar
<input type="checkbox"/> long handle (see on the pictures) firm, 4 cm above back height N° 623701 £ 0	Shape: Straight <input type="checkbox"/> 15 cm (...01) <input type="checkbox"/> 25 cm (...02) Cranked <input type="checkbox"/> 15 cm (...05) <input type="checkbox"/> 25 cm (...06)	<input type="checkbox"/> with long handle (cf. on the left) N° 65.. £235 <input type="checkbox"/> with short handle (cf. on page 8) Not in combination with a drum brake!
<input type="checkbox"/> short handle (see on the pictures) 4 cm above back height Not in combination with a drum brake! N° 623703 £26/P		<input type="checkbox"/> Push bar between extendable push handles with long handles (cf. on the left) Incl. extendable push handles N° 6550 £369
		N° 65..+ 623702 £259

Brakes				
Knee lever brake	Bowden cable brake	Drum brake	Single-hand brake	Roll-back blocking
<input type="checkbox"/> Standard N° 3525 £ 0	<input type="checkbox"/> Bowden cable brake, integrated in activity side guards Only with activity side guards N° 5024	<input type="checkbox"/> for standard-, profile or lightweight wheels (N° 21..30/31/81), incl. brake lever for attendant	Knee lever brake with single hand control Mounting <input type="checkbox"/> left (...01) <input type="checkbox"/> right (...02)	<input type="checkbox"/> Averts automatically the risk of rolling backwards without affecting forward movements Recommended for a user weight up to max. 90 kg A knee lever brake function is included with the rollback blocking! It is not possible to select an additional knee lever brake.
<input type="checkbox"/> lockable in activated or deactivated position N° 3513 £165				
<input type="checkbox"/> Pull to lock N° 3529 £58	N° 3531 £200	N° 220036 £289	N° 3509.. £279	N° 3526 £330

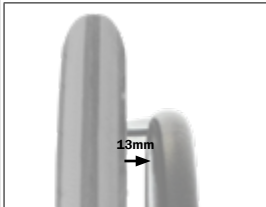
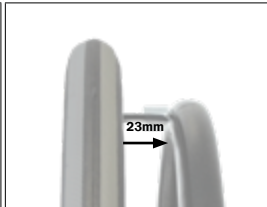
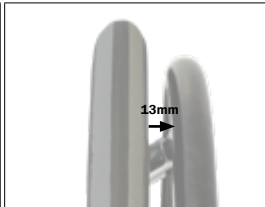
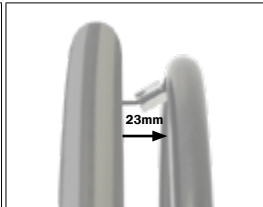
Brake lever extension		Wheel size and wheel camber		
Straight 6 cm	Cranked 12 cm	Wheel size	Wheel camber	
Straight, 6 cm <input type="checkbox"/> with top cover N° 3510 £50/P	Cranked, 12 cm <input type="checkbox"/> with top cover N° 3515 £54/P	Size in inches <input type="checkbox"/> 22" <input type="checkbox"/> 24" <input type="checkbox"/> 26" (N° 212601) AC 180,-€ each pair	Camber (Standard wheels) <input type="checkbox"/> 0° <input type="checkbox"/> 2° <input type="checkbox"/> 5° <input type="checkbox"/> 8°	Camber (drum brake wheels) <input type="checkbox"/> 2° (not recommended) <input type="checkbox"/> 5° <input type="checkbox"/> 8°
Straight, 6 cm <input type="checkbox"/> with ball knob <input type="checkbox"/> with golf ball knob N° 3512 £58/P	Cranked, 12 cm <input type="checkbox"/> with ball knob <input type="checkbox"/> with golf ball knob N° 3516 £68/P	N° 212601 £ 0	N° 212601 £ 0	N° 212601 £ 0

To see the latest versions of our order forms, please visit www.sorgrollstuhltechnik.de/download-portal

Mounting of handrims Please indicate the desired kind of mounting!			
Standard tight	Standard wide	High tight	High wide
			

Handrim options			
Silicone	Ergo rubber inlay	Maxgrepp handrim	Ergonomic handrim
			





Wheel				
Standard wheel	Profile wheel	Lightweight wheel with standard hub	Lightweight wheel with drum brake hub	Double handrim (not possible with 26"-wheels)
<input type="checkbox"/> All-round wheel Additional weight of approx. 900g/pair compared to lightweight wheels	<input type="checkbox"/> Unity of handrim and rim, reduces the risk of finger injuries Additional weight of approx. 800g/pair compared to lightweight wheels	<input type="checkbox"/> with standard hub Very lightweight, incl. aluminium handrim Weight reduction of approx. 900g/pair compared to standard wheels THE STANDARD HUB IS INCOMPATIBLE WITH THE DRUM BRAKE (N° 220036)! No solid tyres possible for 26" wheels.	<input type="checkbox"/> with drum brake hub , incl. black aluminium handrim Only in combination with drum brake (N° 220036) (Additional charge 310,-€) Weight reduction of up to 1.1 kg/pair compared to standard drum brake wheels Package price for lightweight wheels incl. drum brakes and brake lever for the attendant 420,-€/pair. Not possible with 26" wheels	with standard hub and double handrim, Only up to 5° camber Mounting <input type="checkbox"/> left <input type="checkbox"/> right N° 2614 £949 with drum brake hub and double handrim Mounting <input type="checkbox"/> left <input type="checkbox"/> right N° 2615 £1050 <input type="checkbox"/> Handrim for opposite site N° 261435 £149 Distance of handrims¹ <input type="checkbox"/> standard 18mm (...11) <input type="checkbox"/> tight 9mm (...12)
N° 21..30 £ 0	N° 21..31 £ 0	N° 21..76 £139	N° 21..81 £100	N° 26.. £ 0



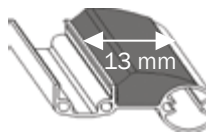
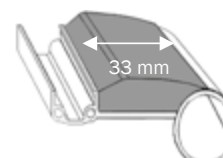

¹ Double handrim, distance of handrims **tight**: Not in combination with hand rim cover or coated hand rim.

Tyres		
Standard	Standard	Performance
Pneumatic: <input type="checkbox"/> Schwalbe Right Run, 1" (...13) <input type="checkbox"/> Standard tyres 1 3/8" (...21)	Solid tyres: <input type="checkbox"/> Standard tyres 1" (...11) <input type="checkbox"/> Standard tyres 1 3/8" (...21) 1 3/8" tyres not for lightweight wheels and 26" wheels	<input type="checkbox"/> Schwalbe Marathon Plus 1" , pneumatic (black), pneumatic flat free tyres Only for 22" und 24" wheels
N° 20.. £ 0	N° 23.. £ 0	N° 20..12 £65

Handrims			
Mounting (standard wheels)	Mounting (lightweight wheels)	Ergonomic handrim	Design handrims
<input type="checkbox"/> Standard / tight <input type="checkbox"/> Standard / wide <input type="checkbox"/> High / tight <input type="checkbox"/> High / wide Material: <input type="checkbox"/> Stainless steel (...01) <input type="checkbox"/> Alu, silver anodized(...75)	<input type="checkbox"/> Standard / tight <input type="checkbox"/> Standard / wide <input type="checkbox"/> High / tight <input type="checkbox"/> High / wide Material: Alu Mounting high is not possible with lightweight wheels with drum brakes.	<input type="checkbox"/> handrim with ergonomic handrim profile, black anodized with built-in rubber grip Only for 24" and 26" wheels	<input type="checkbox"/> Aluminium handrims coated in frame colour
N° 30.. £ 0	N° 30..75 £ 0	N° 3424.. £369	N° 303000 £48/P

Handrim options			
Silicone <small>Not for double handrim 20"</small>	PVC	Ergo rubber inlay	Maxgrepp handrim
Detachable silicone cover, black (soft surface) <input type="checkbox"/> for standard wheel (22-24) <input type="checkbox"/> for profile wheel (...02) <input type="checkbox"/> for lightweight wheel (...05)	<input type="checkbox"/> Handrim coated with black PVC, (<i>Tetra Grip</i>) Only for standard and lightweight wheels	<input type="checkbox"/> Rubber inlay, 13 mm wide, Only for profile wheels	<input type="checkbox"/> Allows pushing with the heel of hands (soft surface), Only for standard and lightweight wheels, not for 26" wheels
N° 32.. £136	N° 33.. £320		
For double handrim Detachable silicone cover, black <input type="checkbox"/> for inside rim <input type="checkbox"/> for outside rim <input type="checkbox"/> for opposing side Not in combination with double handrim distance tight N° 2612	For double handrim <input type="checkbox"/> Handrim coating for double handrim, both handrims (inside and outside), coated with black PVC N° 262402 £310 <input type="checkbox"/> Handrim coating for opposing side of the double handrim, coated with black PVC		
N° 3205 £75/pcs	N° 262401 £179	N° 32..01 £180	N° 34.. £395



Caster wheels				
Standard PU	Standard solid rubber	Standard pneumatic	Design PU	Design solid rubber
				

Steering options		Frame options	
Single-hand aid	Locking mechanism	Outdoor Front End	Anti-tipper
			

To see the latest versions of our order forms, please visit www.sorgrollstuhltechnik.de/download-portal

Spoke cover		Design spoke covers / Design curved back		
Transparent	Design spoke covers		Design curved back	
<input type="checkbox"/> transparent (..00)	<input type="checkbox"/> www.speichen-schutz.de	<input type="checkbox"/> www.wheelchairgadgets.com	<input type="checkbox"/> Optional: child's name on spoke cover: Name: _____ Only for Design Decor	<input type="checkbox"/> Foil for curved back plate with the same design as the specified spoke cover Only with curved back plate
N° 25.. £150/P	N° 25..26 TBD	N° 25..27 TBD		N° 2527 £110

Caster wheels				
Standard PU	Standard solid rubber	Standard pneumatic	Design PU	Design solid rubber
Polyurethane: <input type="checkbox"/> 4" (2812) <input type="checkbox"/> 5" (2805) <input type="checkbox"/> 6" (2803)	Solid rubber, grey: <input type="checkbox"/> 4" (2804) <input type="checkbox"/> 5" (2809) <input type="checkbox"/> 5,5" (2802) <input type="checkbox"/> 6" (2811) <input type="checkbox"/> 7" (2813)	Pneumatic, grey: <input type="checkbox"/> 6" (2808) <input type="checkbox"/> 7" (2807)	Polyurethane, transparent, with LEDs: <input type="checkbox"/> 4" (2820) <input type="checkbox"/> 5" (2834)	Solid rubber black, with alu rim: <input type="checkbox"/> 4" (2835) <input type="checkbox"/> 5" (2836) <input type="checkbox"/> 6" (2838)
£ 0	£ 0	£ 0	£ 0	£ 0

Caster forks				
Standard aluminium	Design aluminium	Hemi-Adapter	Quick-release axle	Change set
<input type="checkbox"/> Alu fork, black anodized 	<input type="checkbox"/> Alu fork, coated in chosen frame colour  (Colour example)	to reduce the front seat height around <input type="checkbox"/> 25 mm (..40) around <input type="checkbox"/> 40 mm (..41) See table p. 16	<input type="checkbox"/> Alu caster fork with quick-release axle (see left side) Not possible with Outdoor Front End, track fixation or locking (N° 2850/2851)	<input type="checkbox"/> Additional set of changeable caster wheels for N° 2721, incl. caster wheels and caster forks (see left side) Please indicate the desired wheel N°: Wheel N° _____ Only possible with N° 2721 Not possible with Outdoor Front End, track fixation or locking (N° 2850/2851)
N° 2826 £ 0	N° 2829 £42	N° 2805.. £129	N° 2721 £162	N° 2830 £239

Steering options		
Single-hand aid	Track fixation	Locking
Mounting <input type="checkbox"/> left (..51) <input type="checkbox"/> right (..52) Not with bowden cable brake N° 3531, desk side guard N° 4610 and long side guard N° 4611	<input type="checkbox"/> Caster wheel track fixation, straight Not with caster fork with quick-release axle N° 2721 and N° 2830	<input type="checkbox"/> Locking mechanism for track fixation Not with caster fork with quick-release axle N° 2721 and N° 2830
N° 26.. £439	N° 2851 £142	N° 2850 £180

Frame options				
Anti tipper	Wheel base extension	Outdoor-Front-End	Splash guard	Baggage holder
Swingaway installation Mounting <input type="checkbox"/> right <input type="checkbox"/> left <input type="checkbox"/> pair	<input type="checkbox"/> Wheel base extension approx. 10 cm to the back	<input type="checkbox"/> Outdoor Front End, adjustable in width and length, facilitates significantly active and passive driving on soft or rough surfaces, incl. mounting aid	<input type="checkbox"/> Splash guard for Outdoor Front End, made of plastic 	<input type="checkbox"/> Transport aid, aluminium, mounted on leg support
N° 7215 £119/pcs	N° 7601 £230	N° 599520 £399	N° 59951212 £79	N° 910110 £90

Frame Options	
Water bottle	Sun shade

Head rests <small>Measures in mm</small>		
Model 1	Model 3	Model 4
shell-shaped	curved - small	curved - large

Belt systems			
2-point pelvic belt	4-point pelvic belt	Chest-shoulder belt	Protection cap
with plastic fastener 	with metal fastener 		only for metal fastener

Lateral support	
Swing-away laterals, large	
Holder adjustable in three dimensions, size 2, incl. linkage and ball-and-socket joint (without pad) 	Pad, incl. removable cover black (only for holder of size 2) 15x10 cm (.04) 18x13 cm (.06)

Therapy tables		
Transparent	Beech wood (varnished)	Design (example)

Frame options				
Water bottle	Step tube	Crutch holder	Sun shade	
<input type="checkbox"/> Water bottle 750 ml light PET-bottle, incl. holder only with stabilizer bar (N° 6400)	Mounting <input type="checkbox"/> right <input type="checkbox"/> left <input type="checkbox"/> pair	Mounting <input type="checkbox"/> left <input type="checkbox"/> right <input type="checkbox"/> pair	<input type="checkbox"/> Size 1 (only up to SW38) variably adjustable sun shade, in black Usable height (from the top edge of the seat plate/seat cover to the apex) = selected back height + 40 cm Example: BH 30 + 40 cm = 70 cm	<input type="checkbox"/> Size 2 (just from SW40) variably adjustable sun shade, in black Usable height (from the top edge of the seat plate/seat cover to the apex) = selected back height + 55 cm Example: BH 30 + 55 cm = 85 cm
N° 790101 £35	N° 7400 £70/pcs	N° 7101 £37/pcs	N° 910301 £220	N° 910302 £240

Positioning aids Here you will find a small selection to mark. More positioning aids in separate order form in our download area.				
Separate order form	2-point pelvic belt	4-point pelvic belt	Head rests with holder	
<p>PLEASE REGARD On the separate order form „Positioning aids“ you will find many different products for positioning, e.g.:</p> <ul style="list-style-type: none"> • belts, • fixations and corresponding connections, • abduction wedges, • side truss pads, • head rests, • and more...  <p>Order form „Positioning aids“, available in download area.</p> <p>On the order form refer to this new wheelchair order/enquiry.</p>	<input type="checkbox"/> with plastic fastener 129,-€ <input type="checkbox"/> with metal fastener 149,-€ The size is determined by us according to the chosen wheelchair measurements.	<input type="checkbox"/> with plastic fastener 159,-€ <input type="checkbox"/> with metal fastener 189,-€ The size is determined by us according to the chosen wheelchair measurements.	All head rests including connection and stabilizer bar <input type="checkbox"/> Model 1, (...21) shell-shaped small <input type="checkbox"/> Model 3, (...23) curved small <input type="checkbox"/> Model 4, (...24) curved large	
	N° 780502	N° 780504		
	Chest-shoulder belt <input type="checkbox"/> Chest-shoulder belt without zipper	Protection cap <input type="checkbox"/> protection cap for metal fastener Makes independent opening for the patient difficult.		
	N° 7810 £179	N° 78050210 £15	N° 6861.. £310	

Lateral support (from BH30 with extendable push handles/from BH35 with standard push handles)		
Swing-away laterals, large		
Holder adjustable in three dimensions, size 2, incl. linkage and ball-and-socket joint (without pad) <input type="checkbox"/> for left side (...01) <input type="checkbox"/> for right side (...02)	Additional joint extension (5.5 cm) for large truss pads 1 pcs. 2 pcs. <input type="checkbox"/> <input type="checkbox"/>	Pad, incl. removable cover black (only for holder of size 2) 1 pcs. 2 pcs. <input type="checkbox"/> <input type="checkbox"/> 15x10 cm (...04) <input type="checkbox"/> <input type="checkbox"/> 18x13 cm (...05)
N° 685902 £179/pcs	N° 68590203 £55/pcs	N° 685902.. £50/pcs

Therapy tables			
Mounting	Transparent	Beech wood (varnished)	Design
Adjustable in height and distance, plugged under arm rests on both sides Arm pads required!	<input type="checkbox"/> Size 1 45 x 36 cm N° ..10 £289	<input type="checkbox"/> Size 1, 50 x 40 cm N° ..13 £310	<input type="checkbox"/> Number of design for plexiglas therapy table according to www.wheelchairgadgets.com
	<input type="checkbox"/> Size 2 59 x 45 cm N° ..11 £300	<input type="checkbox"/> Size 2, 60 x 50 cm	
	<input type="checkbox"/> Size 3 70 x 50 cm N° ..12 £325	<input type="checkbox"/> Size 14 £349	
N° 9207..	N° ..12 £325	N° ..14 £349	N° 920099 £90

Transport brackets (from back height 30)	
Compatibility with Outdoor-Front-End	Transport brackets
<p>Please tick appropriate box if number N° 58507522 was selected (Without ticking an appropriate box, delivery will be without compatibility to additional systems):</p> <input type="checkbox"/> Outdoor-Front-End (restraint brackets at the front) <input type="checkbox"/> Neither Restraint brackets must be replaced by a subsequent fitting of an Outdoor-Front-End	<input type="checkbox"/> Transport brackets (4 pieces) for transportation in a handicapped accessible passenger car N° 58507522 £329

Configuration and Adjustments

Axle plate bore holes alter the seat height by ± 2 cm each

All specifications measured WITHOUT cushions!

The mounting of a short or a long caster fork depends on the desired measures indicated above.

Lower leg length: The maximal LLL possible results from the formula „chosen seat height front minus steering wheel diameter“. Larger LLL are possible dependent on the chosen seat depth, the size and position of the rear wheel and the depth adjustment of the foot rest. The setting range for the „internal mounting“ of the leg support is - at a distance from the top edge of the seat to the foot rest (corresponding to LLL minus cushion thickness) - 2.5-30 cm, for „external mounting“ 29.5-48 cm.

Please note: When using the Hemi-Adapter (N ° 280540/41) for the caster connection, the values for the front seat height of the table below are reduced by 2.5 and 4 cm, respectively. **Please also note the possible rear seat height.**

All measures ± 5 %

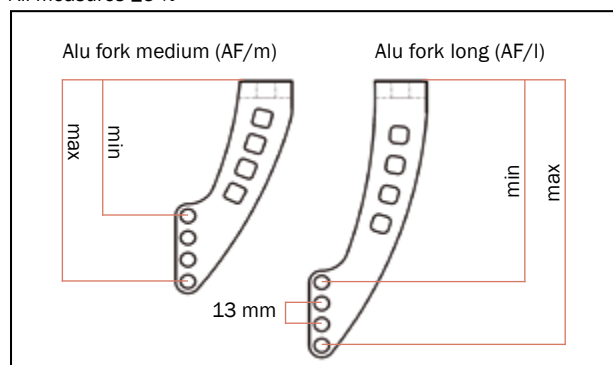

Seat height front	Sport frame Size 4, Size 5		Sport frame XL	
Alu fork	Min.	Max.	Min.	Max.
4" AF/m	41.5	45.5	45.5	49.5
4" AF/l	45.5	49.5	49.5	53.5
5" AF/m	43	47	47	51
5" AF/l	47	51	51	55
5.5" AF/m	45	47.5	49	51.5
5.5" AF/l	47.5	51.5	51.5	55.5
6" AF/m	45.5	48	49.5	52
6" AF/l	48	52	52	56
7" AF/m	48	49.5	52	53.5
7" AF/l	49.5	53.5	53.5	57.5

Seat height front	Sport frame Size 4, Size 5		Sport frame XL	
Synthetic fork	Min.	Max.	Min.	Max.
4" SF	41.5	43	45.5	47
4" SF/l	42.5	44.5	46.5	48.5
5" SF	44.5	44.5	48.5	48.5
5" SF/l	45.5	47.5	49.5	51.5
5.5" SF	45	45	49	49
5.5" SF/l	44.5	46.5	48.5	50.5
6" SF	45.5	45.5	49.5	49.5
6" SF/l	47	47	51	51
7" SF/l	48.5	48.5	52.5	52.5

	Sport frame Size 4, Size 5		Sport frame XL	
Seat height back	Min.	Max.	Min.	Max.
22"x1"	36	48	40	52
22"x1 3/8"	37	49	41	53
24"x1"	38.5	50.5	42.5	54.5
24"x1 3/8"	39.5	51.5	43.5	55.5
26"x1"	40.5	52.5	44.5	56.5
26"x1 3/8"	42	54	46	58

To see the latest versions of our order forms, please visit www.sorgrollstuhltechnik.de/download-portal

Electric drives and systems		
Recommendations	Provider	Information
1. For all possible drives and systems we recommend casters of 6" or higher. 2. Please regard the respective mounting possibilities and specifications given on the homepages indicated on the right	for example www.aat-online.de or www.alber.de	Restrictions and adjustments to the installation and the final configuration of the wheelchair are the responsibility of the providers of the additional systems.

Configurations and Adjustments

All measures $\pm 5\%$

	Sport frame Size 4	Sport frame XL
Possible distances 'top edge of seat to top edge of foot plate(s)' at mounting of leg support		
<i>(possible lower leg lengths = top edge of seat to top edge of foot plate(s) PLUS seat cushion)</i>		
LS int.	4.5 - 32	8.5 - 36
LS ext.	31.5 - 48	35.5 - 52
Possible wheel sizes		
	22" - 24"	24" - 26"
Possible combination 'wheels/caster wheels'		
22"x1"	4"-6"	
22"x1 3/8"	4"-6"	
24"x1"	4"-6", 7"***	4"-7"
24"x1 3/8"	4"-6", 7"*	4"-7"***
26"x1"		4"-7"
26"x1 3/8"		4"-7"
	* Only at wheel position 1 or 2 or at position foot plate(s) above the caster wheels	** Only at wheel position 1, 2 or 3 or at position foot plate(s) above the caster wheels
	** Only at wheel position 1, 2 or 3 or at position foot plate(s) above the caster wheels	

Terms and conditions

1. Preface and Scope

(1) Our terms and conditions apply exclusively. Any deviating, opposing, or complementing terms and conditions on the part of the business partner do not form integral part of contract unless explicitly approved of by us. There are no exceptions to the consent requirement, which also applies in cases where we conduct deliveries without restrictions while aware of the business partner's terms and conditions.

(2) Agreements made in the individual case with the purchaser (including side-agreements, supplements, and alterations) always take priority over these terms and conditions. A contract or our confirmation - both in written form - are authoritative for the content of such arrangements.

(3) Any legally relevant declarations and notifications the purchaser submits to us after conclusion of the contract (e.g. setting of deadlines, notice of defects, declarations of rescission or abatement) require the written form to be valid.

(4) Any information on the application of legal regulations serves the mere purpose of clarification. All regulations are legally binding without any such clarifications unless explicitly altered or excluded in these terms and conditions.

2. Prices

All prices are ex works, excluding insurance and packaging. The prices are net prices; the value-added tax is stated and charged separately according to the legally binding rate at the time of invoicing. The prices valid on the day of delivery are binding unless explicitly arranged otherwise.

3. Conclusion of Contract

SORG's offers are invitatio ad offerendum (invitations to treat). Ordering goods counts as an obligatory offer of contract on the part of the purchaser. Unless the order suggests otherwise, we have the right to accept this contract offer within two weeks time after reception. The acceptance of an offer of contract is effected by the confirmation of the order.

4. Terms of Payment

(1) Provided that no other agreements exist, payment is to be made by paying in advance - 50% at placing of order, 50% pre-delivery of goods. The purchaser bears any costs arising from transactions or discounting.

(2) If a 30-day payment deadline is exceeded, a delay rate of 9% on top of the respective base rate of the European Central Bank falls due without the need for prior notices. Beyond that, the purchaser is charged 3,- € for any reminder sent. We reserve the right to make use of the commercial due rate according to § 353 HGB. A higher damage for delay may be enforced via a suitable verification.

5. Offers and Validity

All current price lists are generally valid until December 31 of the respective year, or until new price lists are published. The latest version of the price list will always be provided on our homepage. Offers older than 3 months at that point expire and must be replaced with new offers and prices.

6. Time of Delivery and Delay

We state the terms of delivery when accepting the order. The delivery date is non-binding and has mere guideline value - especially with regard to customised products. The terms for delay in delivery are defined by legal regulations. In any case, a writing notice issued by the purchaser is necessary for them to take effect.

7. Force Majeure (Act of God)

(1) SORG is not to be held responsible for the following delays of delivery. This also applies if these causes occur with respect to legal representatives, auxiliary persons, or deliverers of SORG: Circumstances of force majeure as well as other extraordinary events that are unpredictable and unavoidable for, and not caused by, SORG, and that only occur after ordering or reserving, and that SORG could not have known about. Moreover, this applies in case of strikes, fire, floods, labour disputes, business disruptions, altered magisterial approbation and legal situation, and magisterial orders which are not due to operational risks.

(2) In the cases of paragraph 1, SORG is eligible to delay delivery/performance for the time of hindrance as well as an appropriate start-up time. If SORG thus causes unacceptable complications for the purchaser, both SORG and the purchaser are eligible to withdraw from the contract. Circumstances that only lead to a temporal and hence acceptable delay of delivery and performance are excluded from this right. The legal rights of the client remain unaffected.

8. Dispatch

We generally dispatch uncovered by insurance and at the recipient's risk. We transfer the risk of accidental loss or deterioration of the goods as well as delay on to the client at the moment of passing the goods on to the forwarder, bearer, or any other person/institute responsible for delivery. SORG will make any effort to respect the client's wishes in terms of path and kind of delivery. Any costs caused by this (including agreed carriage free delivery) are to be covered by the client.

In the case of carriage free delivery conducted by SORG, the recipient is required to put forward any carriage costs for a refund. If the client wishes the dispatch to be delayed, any risk of loss or deterioration of the goods is carried by the recipient from the first day of readiness for dispatch. The goods dispatched are only insured upon special demand and at the cost of the recipient.

9. Damage through Delivery Angelieferte Gegenstände sind, auch wenn sie unwesentliche Mängel Upon delivery, the goods need to be checked for obvious damage in the presence of the bearer. Any damage is to be documented in a written form and co-signed by the bearer. This protocol is to be forwarded to us immediately. Delayed reclamations, or reclamations not signed by the bearer, cannot be taken into account.

10. Warranted Features, Receipt, and Technical Alterations

Delivered objects, even with minor damage, are to be accepted by the client, even if §433 paragraph 1 BGB is not fulfilled. Partial deliveries are permissible. Features only count as warranted if explicitly designated as such. A warranty of condition can only be asserted explicitly and in a written form. SORG reserves the right for technical alterations, especially for solutions of equal or higher value.

11. Warranty for Defects

(1) SORG warrants for any defects of delivered new goods for 12 months as long as the purchaser is not the user (§§ 474, 13 BGB). Should the purchaser be the user then the warranty period is 2 years for new goods, for used goods 12 months. Should the purchaser also be an entrepreneur, then the liability for used items is void, as long as there is no claim for compensation according to N° 12.

(2) The purchaser's claim for defects presuppose that he has attended his obligation to give notice of defects on the legal grounds for his reasons of inquiry (§§ 377, 381 HGB). If defects are found during the inspection or at a later point, we are to be notified in writing without delay. The notice counts as not delayed if issued within two weeks. Posting the notice on time suffices for the keeping of the term. Independently from this obligation to inspect and give notice, the purchaser

is to report obvious defects (including wrong and short delivery) within two weeks upon delivery (again, posting the notice on time suffices). If the purchaser misses the proper inspection and/or notice of defects, we do not warrant for the reported defects. If the delivered good is defected, we may choose to conduct supplementary performance either by repairing the defect (subsequent improvement) or by delivering flawless goods (compensation delivery). Our right to refuse the chosen method of supplementary performance on the respective legal grounds remains untouched.

(3) Our liability for defects expires when alteration or maintenance works are done by the client or a third-person-party without our prior written permission. Consequences of excessive strain, negligent or incorrect handling, and violent damage are excluded from the warranty for defects.

12. Further Liability

(1) With respect to compensation - regardless of the legal cause - SORG is only liable in case of malice and act of gross negligence. In case of slight negligence, SORG is only liable for damage of life, body, health, and for damage caused by the negligence of an essential contractual obligation (an obligation whose fulfilment make the proper realisation of the contract possible in the first place and in whose fulfilment the contract partner regularly trusts and can trust). In this case, however, our liability does not exceed the covering of predictable, typically occurring damage.

(2) A free right to termination on the part of the purchaser (acc. to § 651, 649 BGB in particular) is precluded. Otherwise, the usual prerequisites and legal consequences apply.

13. Costs of Supplementary Performance

Costs of supplementary performance cannot be charged on SORG's account.

14. Voluntary Withdrawal of Goods

SORG is not obliged to take back any delivered end products or parts thereof. If SORG voluntarily decides otherwise in individual cases (especially for therapeutically altered requirements or deaths), SORG refunds a maximum of 75% of the delivery costs for unused parts whose delivery does not date back more than three months. There is no legal obligation concerning withdrawal in this respect. Deliveries which date back more than three months as well as sewed parts and customised products are not returnable. A copy of the delivery note or the bill serves as proof of age of delivery.

15. Reservation of Ownership

Goods delivered by SORG remain the property of SORG until any obligations from the parties' business contract on the part of the purchaser have been redeemed. This also applies if SORG has adapted individual or all claims into a running account which has been balanced and acknowledged. The purchaser has the right to dispose of the goods in the proper course of business. The purchaser hereby yields all claims to SORG which arise from the resale against the purchaser or third parties. The purchaser is authorised to withdraw these claims even upon conveyance. SORG's right to withdraw the claims remains untouched. However, SORG is obliged not to withdraw the claims as long as the purchaser complies with his duty of payment and any other duties. SORG has the right to demand that the purchaser makes known the yielded claims and their debtors, that he provides all information necessary for conveyance, and that he hands in all associated documents. As long and insofar the reservation of ownership is intact, the purchaser must not transfer any goods for securing or bailment without SORG's permission. The purchaser may process or alter the goods for the benefit of SORG exclusively. If processed with other goods which do not belong to SORG, SORG obtains co-ownership of these new goods in relation to the invoice value to the cost price of the other processed goods. If a third party interferes with SORG's ownership, the purchaser is to notify SORG immediately. The purchaser must not make any agreements with other purchasers which may exclude or limit SORG's rights. In particular, the purchaser must not make any agreements which destroy or limit the advance assignments to SORG. If the estimated value of the existing guarantees exceeds the claims to be ensured by more than 20%, SORG is insofar obliged to release by request of the purchaser.

16. Copyright Protection

If SORG conveys any images, drawings, indications of weight or measurements, technical documentations, or other product descriptions and documents (including electronic ones), the respective indications only apply if explicitly stated that they do. SORG reserves ownership and copyright of all these documents. They may only be made available to third parties upon SORG's explicit permission.

17. Place of Fulfilment, Place of Jurisdiction, and Severability Clause

(1) The law of the Federal Republic of Germany applies for these Terms and Conditions and all legal relations between us and our business partners. All international and supranational (contractual) legal systems, the UN Convention on Contracts for the International Sale of Goods in particular, are hereby excluded. Prerequisites and effects of the reservation of ownership acc. to no. 15 are subject to the right of the respective storage location of the good if the choice of law made in favour of the German law is illegitimate or ineffective. The only place of jurisdiction (also on an international basis) for any disputes arising directly or indirectly from the contractual relationship is, according to German Commercial Code, our office in Oberhausen-Rheinhausen, Germany. However, we also have the right to file a suit concerning the general jurisdiction of the purchaser.

(2) If any clause in these Terms of Conditions should turn out to be ineffective, this does not affect the effectiveness of all other clauses.

Technical alterations and misprints reserved. As of: January 2017

SORG Rollstuhltechnik GmbH + Co. KG
Benzstr. 3-5, 68794 Oberhausen-Rheinhausen / Germany
Phone +49 7254 / 9279-0
Fax +49 7254 / 9279-10
info@sorgrollstuhltechnik.de, www.sorgrollstuhltechnik.de