

Little Wave "Arc" *XP*

Little Wave "Arc" *XPe*

Little Wave "Arc" *TTL*

USER INSTRUCTION MANUAL & WARRANTY



I. INTRODUCTION

Thank you for purchasing a Ki Mobility wheelchair!



WARNING: Do not use this without first reading this entire manual. Use without first reading this entire manual could result in serious injury to the user and/or attendant.

Ki Mobility recommends training by an Assistive Technology Professional (ATP) or other competent clinical or technical professional in the safe use of this chair prior to use.

If you have any questions or concerns about any aspect of this wheelchair, this manual or the service provided, do not hesitate to contact your authorized supplier, an authorized representative or Ki Mobility. Ki Mobility can be reached at:

(1)715-254-0991



Ki Mobility
5201 Woodward Drive
Stevens Point, WI 54481
U.S.A



www.kimobility.com

Or via our Authorized EU Representative:



Ki Mobility Portugal, Unipessoal Lda
Rua Santos Pousada, 157 4º andar sala 17
4000-485 Porto



II. TABLE OF CONTENTS

I.	INTRODUCTION	
II.	TABLE OF CONTENTS	
III.	NOTICE - READ BEFORE USE	
	A. Use	3
	B. Your Safety	3
	C. Signal Words	3
	D. Serial Number Identification	4
	E. Symbol Glossary	4
	F. General Warnings and Cautions	5
	G. Positioning Belts or Harnesses	6
	H. Riding Your Wheelchair	6
	I. Power Drives	8
	J. Your Wheelchair and the Environment	9
	K. Modifying your Wheelchair	9
	L. Wheelchair Stability	9
	M. Aftermarket Seating	10
IV.	WHEELCHAIR USE & CONFIGURATION	
	A. Ascending Stairs	11
	B. Descending Stairs	11
	C. Transfers	12
	D. Transit Use	12
	E. Cushion Use	15
	F. Your Arc & Its Parts	16
	G. Folding and Unfolding the Wheelchair	17
	H. Height Adjustable T-Arm	19
	I. Pediatric T-Arm	20
	J. Angle Adj. Locking Extendable Flip Up Armrest	21
	K. Swing Away Hangers	21
	L. Swing Away Hangers with 4-Way Latch	22
	M. Extension Tubes	23
	N. Elevating Leg Rest	23
	O. Pro Elevating Leg Rest	24
	P. Pediatric Elevating Leg Rest	27
	Q. Contracture Footrest	29
	R. Multi-Angle Footrest	30
	S. Backrest	31
	T. Reclining Backrest	33
	U. Tilt Mechanism	34
	V. Rear Wheels	37
	W. Wheel Locks	38
	X. Drum Brake	39
	Y. Attendant Foot Lock	40
	Z. Surface Temperature	40
	AA. Anti-Tips	41
	BB. Hemi Wheel Lock	44
	CC. Canopy	45
	DD. Folding Adjustable Handle	46
	EE. Folding Rigidizer Bar	46
V.	MAINTENANCE AND CARE	
	A. Maintenance Table	47
	B. Cleaning	48
	C. Storage	48
	D. Disposal	49
VI.	TROUBLESHOOTING	
	A. Symptoms and Solutions	50
VII.	WARRANTY	51

III. NOTICE - READ BEFORE USE

A. Use

Intended Use: Ki Mobility Manual wheelchairs are manually operated devices with wheels that are intended for medical purposes to provide mobility to persons restricted to a sitting position.

Intended User: The wheelchair is intended for users with physical disabilities or limitations that inhibit the ability to functionally ambulate. Wheelchair users may be either dependent or independent in the use of the wheelchair for mobility.

Indications for Use: Possessing a need for wheeled mobility that the specific model can be configured to meet, as determined by the user, caregivers, clinicians, and Assistive Technology Professional (ATP) or other competent clinical or technical professional with appropriate knowledge of the products being considered.

Contraindications for Use: The inability of the specific model to accommodate the needs of the user as determined by the user, caregivers, clinicians, and Assistive Technology Professional (ATP) or other competent clinical or technical professional with appropriate knowledge of the products being considered.

B. Your Safety

Any serious adverse events or injuries related to the use of your wheelchair or its accessories must be reported immediately if the incident directly or indirectly leads to serious health decline or death of the user or other person. Report any serious events and/or injuries to Ki Mobility and, if required by local regulation, the competent health authority where the user and/or other person legally reside.

Do not use this wheelchair without first reading this entire manual. BEFORE riding, you should be trained in the safe use of this chair by an Assistive Technology Professional (ATP) or other competent clinical or technical professional. Ki Mobility manufactures many different wheelchairs that might meet your needs. The recognized best practice for selecting a wheelchair is to consult with an ATP or other competent technical professional and an experienced clinical professional such as a physical therapist, occupational therapist or physician. Final selection of the type of wheelchair, options and adjustments rests solely with you and your technical and clinical professionals. The options you choose, and the set-up and adjustment of the wheelchair have a direct impact on its performance, stability and its ability to meet your needs. Factors to consider that affect your safety and stability are:

- a. Your personal abilities and capabilities including strength, balance and coordination.
- b. The types of hazards and obstacles you might encounter during your day.
- c. The specific dimensions, options and set up. In particular, the seat height, seat depth, seat angle, back angle, size and position of the rear wheels and size and position of the front casters.

C. Signal Words

Within this manual you will find what are referred to as “Signal” words. These words are used to identify and convey the severity of varying hazards. Before using this chair you, and each person who may assist you, should read this entire manual. Please note the Signal word and consider any notes, cautions or warnings. Make sure to follow all instructions and use your chair safely. The Signal word refers to a hazard or unsafe practice that may cause severe injury or death to you or to other persons. The “Warnings” are in three main categories, as follows:

NOTE – Note indicates a potentially hazardous situation which, if not avoided, could result in a decline in the performance of the chair or damage to your wheelchair.



CAUTION: Caution indicates a potentially hazardous situation which, if not avoided, could result in damage to your wheelchair and injury to you.



WARNING: Warning indicates a potentially hazardous situation which, if not avoided, could result in serious injury or death.

These signal words will be placed throughout the manual, where appropriate to highlight the hazardous situation. Refer to Section F. for hazardous situations that will apply to the general use of this wheelchair.

III. NOTICE - READ BEFORE USE

D. Serial Number Identification

The serial number label provides important information about your chair and the serial number is used as the unique identifier for your specific chair. See image below on where to find the serial number on your chair.

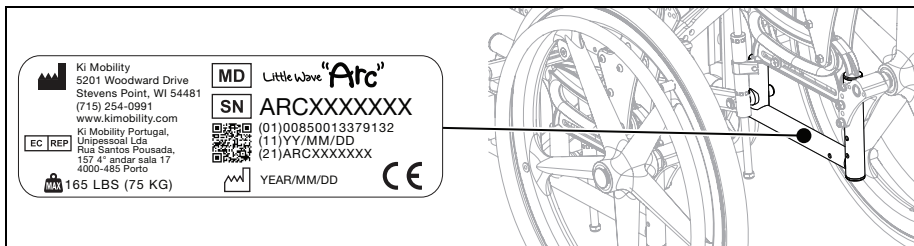

E. Symbol Glossary

SYMBOL	DEFINITION
	Indicates the medical device manufacturer.
	Date of manufacture (YEAR/MM/DD).
	Indicates the need for the user to consult an instruction for safety reasons such as cautions and warnings. If presented on the medical device or packaging, it indicates the need for the user to consult the instructions for safety reasons such as cautions and warnings.
	Indicates the item is a medical device.
	Indicates the manufacturer's serial number so that a specific medical device can be identified.
	Indicates the authorized representative in the European Community.
	Indicates the manufacturer's declaration that the product meets the requirements of the applicable EC directives.
	Indicates the need for the user to consult the instructions for use.
	Indicates the need for the user to consult the listed website for instructions for use in an electronic format.
	Indicates a website where a user may obtain additional information about the medical product.
	Indicates a specified maximum weight limit (lbs/kg).
	Indicates a transit securement point.
	Indicates a potential pinch point.









III. NOTICE - READ BEFORE USE

F. General Warnings and Cautions

WARNING

	Standard
Arc	165 lbs (75 kg)

WARNING: Limits refer to combined weight in pounds of user and all items carried. Do not exceed weight limit of chair. Exceeding weight limit may damage your chair or may increase your risk of falling or tipping over. A tip-over or fall could result in serious injury or death.

-  Do not use chair for weight training. The movement of the additional weight alters the chair's center of gravity increasing your risk of tipping over. A tip-over could result in damage to your chair or in serious injury or death.
-  Keep tires inflated to correct tire pressure. Using a chair without properly inflated tires may affect its stability, increasing your risk of tipping over. A tip-over could result in damage to your chair or in serious injury or death to you or others. Correct tire pressure is indicated on the side wall of the tire. Your wheelchair provider can determine if your tires are inflatable if you are unsure.
-  Avoid ramps or slopes inclined more than 9 degrees. Steep slopes increase your risk of falling or tipping over. A tip-over or fall could result in damage to your chair or in serious injury or death to you or others. Do not use chair on ramps or slopes tilted more than 9 degrees (about 2 inches rise/drop per linear-foot): neither up/down nor across.
-  Avoid inclined surfaces slick or coated with ice, oil or water. Slippery inclines could result in an inability to control the wheelchair on the surface and result in a tip-over or fall. A tip-over or fall could result in damage to your chair or in serious injury or death.
-  Avoid leaning over the side or back of your wheelchair to extend your reach. Leaning over chair could change its center of gravity and cause an unstable situation resulting in a fall or tip-over. A tip-over or fall could result in damage to your chair or in serious injury or death.
-  Do not lift wheelchair by its removable parts while occupied. Lifting a wheelchair by removable parts while occupied could cause user to fall or lose control. A fall or loss of control could result in damage to your chair or in serious injury or death.
-  Packaging material must be kept out of the reach of children. Improper handling of packaging materials and the neglect of the duty to supervise children could result in suffocation and serious injury or death.
-  Do not expose the chair and components to any extreme temperatures (e.g. sunlight, sauna, extreme cold). Hypothermia or burns through contact with the chair and components can occur and/or failure of components.

CAUTION

CAUTION: Avoid overtightening bolts and hardware that attach components to the frame. Overtightening could cause damage to the chair; affecting its durability and performance. Damage to the chair could result in injury to the user.

NOTE: Information about tightening hardware can be found in the maintenance section of this manual. If you are unsure how to properly tighten bolts or hardware or lack the tools necessary, consult your authorized supplier.

III. NOTICE - READ BEFORE USE

G. Positioning Belts or Harnesses

WARNING

WARNING: Improper use of positioning belts can cause the user to slide underneath the positioning belt in the wheelchair. If this should happen, chest compression or suffocation due to pressure from the belt can occur. If this occurs, the user's breathing may be hampered causing serious injury or death.



Improper use of positioning belts could cause body parts to become entangled which can restrict mobility and movement, which could result in serious injury or death.

Ki Mobility recommends the use of pelvic positioning belts. Pelvic positioning belts can reduce the risk of falling from your wheelchair.

Positioning belts, such as pelvic positioning belts and anterior trunk harnesses and straps, are designed to assist, retain and support proper positioning and posture in the wheelchair.

- Ensure the user does not slide underneath the positioning belt in the wheelchair seat.
- The positioning belt should have a snug fit; tight enough to hold their position, but not so tight as to restrict breathing. An open hand should be able to fit between the belt and the user.
- Proper use of cushions can contribute to pelvic stability and reduce sliding.
- NEVER Use Positioning Belts:
 - a. As a restraint. A restraint requires a doctor's order.
 - i. Unless you can remove the belts easily in an emergency. If you cannot do this, consult with your health care advisor for other options to help with your posture.
 - b. On a user who is unconscious or agitated.
 - c. As an occupant restraint or safety belt in a motor vehicle. A positioning belt is not designed to replace a seat belt that is attached to the frame of a vehicle, which would be required of an effective seat belt. During a sudden stop, with the force of the stop, the user would be thrown forward. Wheelchair seat belts will not prevent this, and further injury may result from the belts or straps. Reference Transit section of this manual for further information.

H. Riding Your Wheelchair

WARNING









WARNING: Avoid pushing or using your wheelchair on soft, rough, uneven, or slick surfaces (including but not limited to ice, sand, loose soil, grass, gravel, potholes, cracks, and broken pavement). Use on such surfaces could cause the wheelchair to lose stability causing it to tip unexpectedly resulting in a fall or loss of control. A fall or loss of control could result in damage to your wheelchair, serious injury or death.



Always look ahead for potential obstructions or surface transitions that could cause your front caster wheels to catch causing your wheelchair to abruptly stop. Failure to do so could cause the wheelchair to tip unexpectedly resulting in a fall or loss of control. A fall or loss of control could result in damage to your wheelchair, serious injury or death.

III. NOTICE - READ BEFORE USE

H. Riding Your Wheelchair (Continued)

-  Always look ahead for objects or obstructions that your wheelchair could potentially strike. Striking an object or obstruction could cause your wheelchair to tip unexpectedly resulting in a fall or loss of control. A fall or loss of control could result in damage to your wheelchair, serious injury or death. In addition, striking an object or obstruction could cause damage to your wheelchair. The risk of injuries and damage to your wheelchair when striking an object or obstruction increases with your rate of speed.
-  Using your wheelchair on public roads is extremely hazardous and is not recommended. Wheelchair users must obey pedestrian traffic rules. Review the traffic laws in your own state, some states do not permit wheelchair use on public roads.
-  Your balance is affected by the slope of the surfaces you ride on. Because balance is affected, your wheelchair will be less stable when it is at an angle. This is especially true when riding on a slope sideways. Riding your wheelchair on a slope could cause the wheelchair to tip unexpectedly and/or the user to lose stability resulting in a fall or loss of control. A fall or loss of control could result in damage to your wheelchair, serious injury or death.
-  When using your wheelchair in public or private areas (including but not limited to crosswalks, sidewalks, neighborhoods, parking lots and parks) be alert to the danger of motor vehicles. Due to your low position:
 - When lighting is poor use reflective tape on your wheelchair and clothing.
 - If you have the right-of-way always yield until the driver of the motor vehicle has seen you.
-  Use extreme caution when propelling backward. You may be unable to see an obstruction that could cause a tip over. Tipping over could result in damage to your wheelchair, serious injury or death.
-  Ki Mobility does not recommend balancing on just the rear wheels with the front casters off the ground (also known as doing a “wheelie”). A fall or tip over is very likely and could result in damage to your wheelchair, serious injury or death. If you choose to ignore this warning, do not attempt a wheelie unless you have been trained by a clinical or technical professional. You should always have the assistance of an able-bodied person prepared to prevent you from exceeding your tipping point.
-  Do not ride your wheelchair on an escalator. Use of a wheelchair on an escalator could cause a fall, tip-over or loss of control. A fall, tip over or loss of control could result in damage to your wheelchair, severe injury or death.
-  Avoid getting dressed or undressed in your wheelchair. Dressing or undressing in your wheelchair causes your weight to shift. Thus, increasing your risk of falling or tipping over. Falling or tipping over could result in damage to your wheelchair, serious injury or death.
-  Ki Mobility recommends using accessories such as heel loops and calf straps. When used properly, heel loops and calf straps can aid in preventing your legs and feet from accidentally slipping off the footplate or footrest potentially causing your feet to become entangled in the wheelchair and its components or strike the ground. Use of a wheelchair without accessories such as properly fitted heel loops and calf straps can result in a potentially hazardous situation which, if not avoided, could result in injury.

III. NOTICE - READ BEFORE USE

H. Riding Your Wheelchair (Continued)

When using your wheelchair always:

- Scan the area well ahead of your wheelchair as you ride.
- Ensure the surfaces you ride on are level and free of obstacles.
- Remove or cover threshold strips between rooms.
- If your wheelchair has anti-tips make sure they are locked in place when riding your wheelchair (Reference Section AA for proper use of anti-tips).
- Keep both of your hands on the handrims as you go over obstacles.
- Never push or pull off an object to propel your wheelchair.
- Make sure there is not a drop off at the bottom of ramps.
- On an up-slope, lean your upper body forward slightly to prevent tipping backwards.
- On a down-slope, press your upper body backwards to prevent tipping forward.
- Do not attempt to push over obstacles without assistance.
- Ensure all ramps, slopes or curb cuts you attempt to ride on are compliant with ADA (Americans with Disabilities Act) guidelines or the equivalent accessibility guidelines in your region.

ADA Guidelines and more information about accessible design are available at: www.ada.gov

I. Power Drives

WARNING

WARNING: Ensure the power drive system has been validated and approved by the manufacturer for use with your Ki wheelchair and its configuration. Use of an unapproved external power drive system could result in mechanical failure of the wheelchair or cause a fall. A fall could result in damage to your wheelchair, severe injury or death.



Power drive systems change the stability and performance of the wheelchair. Always use anti-tips with your power drive system. Failure to do so could result in your wheelchair tipping over backwards. Tipping over backwards could result in damage to your wheelchair, severe injury or death.



Always look ahead for objects or obstructions that your wheelchair could potentially strike. Power drive systems change the performance of the wheelchair and will increase the risk of tipping unexpectedly if you strike an object or obstruction. Tipping unexpectedly could result in a fall or loss of control. A fall or loss of control could result in damage to your wheelchair. The risk of injuries and damage to your wheelchair when striking an object or obstruction increases with your rate of speed.

Ki Mobility does not recommend the installation of power drive systems on any Ki Mobility wheelchair. Ki Mobility wheelchairs have not been designed or tested by Ki Mobility as power wheelchairs. If you add a power drive system to a Ki Mobility wheelchair, be sure the manufacturer of the power drive system has validated and approved the combination of the power drive system and wheelchair as safe and effective.

III. NOTICE - READ BEFORE USE

J. Your Wheelchair and the Environment

CAUTION

CAUTION: Exposure to water or excessive moisture may cause the metal in the wheelchair to rust or corrode and the fabric to tear. Dry your chair as soon as possible if exposed to water.



DO NOT USE YOUR WHEELCHAIR IN A SHOWER, POOL OR BODY OF WATER. This will cause your wheelchair to rust or corrode and eventually fail.



Do not operate your wheelchair in sand. Sand can get into the wheel bearings and moving parts. This will cause damage and eventually will cause the wheelchair to fail.

K. Modifying your Wheelchair

WARNING

WARNING: NO ONE SHOULD MODIFY THIS WHEELCHAIR EXCEPT BY ADJUSTING IT ACCORDING TO THIS MANUAL OR BY ADDING KI MOBILITY APPROVED OPTIONS. THERE ARE NO APPROVED OPTIONS THAT INVOLVE DRILLING OR CUTTING THE FRAME BY ANYONE OTHER THAN A TRAINED KI MOBILITY ASSOCIATE. Your wheelchair was engineered and manufactured under strict design controls. An integral part of this process is ensuring the various components work together correctly; they have been tested to various standards to ensure quality and are approved to work together. Contact an authorized supplier or Ki Mobility before adding any accessories or components not provided by Ki Mobility. Unapproved modifications or options could lead to fall and cause serious injury or death.

L. Wheelchair Stability

WARNING

WARNING: The stability of your wheelchair could be affected when using on soft, rough, uneven (incline or decline), or slick surfaces (including but not limited to ice, sand, loose soil, grass, gravel, potholes, cracks, and broken pavement). Use on such surfaces could cause the wheelchair to tip unexpectedly resulting in a fall or loss of control. A fall or loss of control could result in damage to your wheelchair, serious injury or death.



Shifting weight in your wheelchair, adding weight to your wheelchair and carry or reaching for objects could affect the stability of your wheelchair. Thus, increasing your risk of falling or tipping over. Falling or tipping over could result in damage to your wheelchair, serious injury or death.



Avoid getting dressed or undressed in your wheelchair. Dressing or undressing in your wheelchair causes your weight to shift. Thus, increasing your risk of falling or tipping over. Falling or tipping over could result in damage to your wheelchair, serious injury or death.



Ki Mobility does not recommend balancing on just the rear wheels with the front casters off the ground (also known as doing a “wheelie”). A fall or tip over is very likely and could result in damage to your wheelchair, serious injury or death. If you choose to ignore this warning, do not attempt a wheelie unless you have been trained by a clinical or technical professional. You should always have the assistance of an able-bodied person prepared to prevent you from exceeding your tipping point.

III. NOTICE - READ BEFORE USE

L. Wheelchair Stability (Continued)

WARNING

WARNING: If the wheelchair is equipped with a system to vary the tilt angle of the seat frame, confirm it is stable throughout the range of angle changes before use. If the wheelchair is not stable throughout the range of tilt angles a fall or tip over is imminent. Falling or tipping over could result in damage to your wheelchair, serious injury or death.

Strategies to minimize the risk of falling:

- Ensure anti-tips are in the correct position (Reference Section N for proper use of anti-tips).
- Lean forward when pushing up an incline.
- Lean back when pushing down a decline.
- Have an attendant behind you to provide assistance.
- Wheelchair set up should be done only by an authorized technician.
- Always use the accessories provided.
- Your wheelchair should be adjusted by an authorized technician when there are changes in your weight or how you sit.
- Always use anti-tips where appropriate (Reference Section for proper use of anti-tips).

To ensure proper stability of your wheelchair, you must make sure the center of gravity and the wheelchair's base of support is correct for your balance and abilities. Many factors can affect these two elements:

- Seat height
- Seat depth
- Back angle
- Seat angle
- Size and position of rear wheels
- Size and position of front casters
- Seating system components
- Tilt position (If applicable)

There are additional actions that can have adverse effects on the stability of your wheelchair. You should consult with an assistive technology professional or clinical professional that is familiar with your needs and capabilities to determine what you are able to do safely while maintaining the stability of your wheelchair.

M. Aftermarket Seating

WARNING

WARNING: The installation of a cushion on a wheelchair could affect the center of gravity of the wheelchair. Changes in your center of gravity may affect your stability in your wheelchair, resulting in tipping over or falling from your wheelchair which may result in serious injury. Always review the instructions for use of your wheelchair to see if changes to the wheelchair may be needed to provide sufficient stability after adding a cushion.



The integrity of your skin can be affected by many aspects of your daily life and medical condition, including the use of this product. Be sure to follow any skin care regimens established by your clinician. Consumers of this product should make sure their skin is inspected routinely for changes as directed by their clinician. Failure to do so could result in serious injury or death.

Selecting the Proper Seating Product

You should consult with a licensed clinician (i.e. Physician or therapist) trained in wheelchair seating and positioning before selecting any seating and positioning product. This will help ensure you receive the right product for your specific needs.

IV. WHEELCHAIR USE & CONFIGURATION

A. Ascending Stairs



WARNING: Do not ascend stairs without the assistance of at least two people who are trained on the below steps and are able to handle the weight of you and the wheelchair. Ascending stairs can be challenging and may result in a fall that could result in damage to your wheelchair, serious injury or death to the user and/or those assisting.

NOTE: When ascending a set of stairs the user should be facing the bottom of the stairs.

1. Remove or turn the anti-tips up when ascending stairs. Always remember to reinstall or turn the anti-tips to the down position after they were removed or turned to the up position. If the anti-tips are left in the down position when ascending stairs, they can be bent or broken. If the anti-tips are bent or broken, they will no longer prevent the wheelchair from tipping over backwards. Tipping over backwards could result in damage to your chair, serious injury or death.
2. Position one person behind the user and one person in front. The person in front and back must hold on to a non-removable part of the wheelchair.
3. The person behind the user tilts the wheelchair back and both attendants lift together. Take one step at a time.

B. Descending Stairs



WARNING: Do not descend stairs without the assistance of at least two people who are trained on the below steps and are able to handle the weight of you and the wheelchair. Descending stairs can be challenging and may result in damage to your wheelchair, serious injury or death to the user and/or those assisting.

NOTE: When descending stairs, the user should be facing the top of the stairs.

1. Remove or turn the anti-tips up when descending stairs. Always remember to reinstall or turn the anti-tips to the down position after they were removed or turned to the up position. If the anti-tips are left in the down position when descending stairs, they can be bent or broken. If the anti-tips are bent or broken, they will no longer prevent the wheelchair from tipping over backwards. Tipping over backwards could result in damage to your chair, serious injury or death.
2. Position one person behind the user and one person in front. The person in front and back must hold on to a non-removable part of the wheelchair.
3. The person behind the user tilts the chair backward and guides the wheelchair down the stairs slow and one step at a time on the rear wheels of the chair.

IV. WHEELCHAIR USE & CONFIGURATION

C. Transfers



WARNING: Be trained and ensure that you can transfer on your own or with a person who can assist you. It is dangerous to transfer on your own as it requires good balance and agility. Be aware there is a point during every transfer when the wheelchair seat is not below you. Failure to perform a transfer properly can result in a fall that could result in severe injury or death.

NOTE: Before transferring out of your wheelchair every caution should be taken to reduce the gap between the two surfaces.

1. Engage the wheel locks to lock the rear wheels.
2. Rotate the casters forward to increase the wheelbase of the wheelchair.
3. Remove or swing away the footrests.
4. Have someone assist you unless you are well experienced and able in transfers.

D. Transit Use



WARNING: Never use your wheelchair as a seat in a motor vehicle unless it has been equipped with the transit option. It is always safest to transfer out of your wheelchair onto a seat in a motor vehicle with appropriate seat and shoulder belts. Using your wheelchair as a seat in a motor vehicle, if not equipped with the transit option, could result in serious injury or death.

The wheelchair equipped with the transit option has been tested to and passed the RESNA WC-4, Section 19: Wheelchairs used as seats in motor vehicles and ISO 7176-19 Wheelchairs -- Part 19: Wheeled mobility devices for use as seats in motor vehicles. RESNA and ISO standards are designed to test the structural integrity of the wheelchair as a seat for use in a motor vehicle. These standards are also designed to create compatibility with Wheelchair Tie-down and Occupant Restraint Systems (WTORS).

Not every wheelchair configuration is compatible with the transit option. Ki Mobility manages the configuration and does not offer this wheelchair except in compatible configurations. If you make changes to your wheelchair after you receive it, you should contact your wheelchair provider or Ki Mobility to make sure it is appropriate to continue to use your wheelchair as a seat in a motor vehicle.

Aftermarket seating may have replaced the original equipment seat and back support designed and tested as part of the transit option. Your wheelchair provider should tell you if the seating they provided is original equipment or replacement aftermarket seating. A complete system of wheelchair frame, seating, Wheelchair Tie-down and Occupant Restraint Systems and a properly equipped motor vehicle, that have all complied with the standards mentioned in this section, should be in place before using a wheelchair equipped with the transit option as a seat in a motor vehicle.

When using your wheelchair as a seat in a motor vehicle you should always observe the following instructions:

IV. WHEELCHAIR USE & CONFIGURATION

D. Transit Use (Continued)

- The rider must be in a forward-facing position.
- The rider and all items carried must not weigh more than 165 lbs (75 kg).
- Backpacks and pouches should be removed and secured separately in the motor vehicle. In the event of an accident these items can become dangerous projectiles, which may injure or kill you or other occupants of the motor vehicle.
- The rider must use a Wheelchair Tie-down and Occupant Restraint System that complies with RESNA WC-4, Section 18: Wheelchair tie-down and occupant restraint systems for use in motor vehicles or ISO 10542-1 Technical systems and aids for disabled or handicapped persons -- Wheelchair tie-down and occupant-restraint systems -- Part 1: Requirements and test methods for all systems.
- Attach the wheelchair tie-downs to the four securement points (two front, two rear) on the wheelchair with the transit option (Fig. 1) in accordance with the wheelchair tie-down manufacturer's instructions and RESNA WC-4, Section 18 or ISO 10542-1, - Part 1.

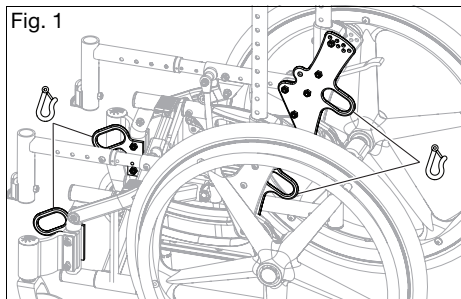

- Attach occupant restraints in accordance with the occupant restraint manufacturer's instructions and RESNA WC-4, Section 18 or ISO 10542-1, Part 1.
- Use of lap belts, chest straps, shoulder harnesses, any other positioning strap system or positioning accessory should not be used, or relied on as an occupant restraint, unless it is marked as such by the manufacturer in accordance with RESNA WC-4, Section 18 or ISO 10542-1, Part 1.
- Use of headrests, lateral supports or other positioning accessories should not be used, or relied on as an occupant restraint, unless it is marked as such by the manufacturer in accordance with RESNA WC-4, Section 18 or ISO 10542-1, Part 1 or RESNA WC-4, Section 20: Wheelchair seating systems for use in motor vehicles or ISO 16840-4 Wheelchair seating -- Part 4: Seating systems for use in motor vehicles.
- Any aftermarket seating should be tested to comply with RESNA WC-4, Section 20 or ISO 16840-4 - Part 4.
- Attach the seating to the wheelchair frame in accordance with the seating manufacturer's instructions and RESNA WC-4, Section 20 or ISO 16840-4 - Part 4.
- Aftermarket accessories such as trays, oxygen tank holders, oxygen tanks, IV poles, back packs, pouches and items not manufactured by Ki Mobility should be removed and secured separately in the motor vehicle. In the event of an accident, these items can become dangerous projectiles which may injure or kill you or other occupants of the motor vehicle.
- If the wheelchair has been involved in an accident, you should not continue to use it, as it may have suffered fatigue, or damage, that may not be visible.

IV. WHEELCHAIR USE & CONFIGURATION

D. Transit Use (Continued)



WARNING: Remove and secure any items temporarily attached to the chair while in a motor vehicle. Leaving items attached to the vent tray, battery tray or oxygen tank holder and not securing them properly and separately in a motor vehicle could result in these items becoming dangerous projectiles in the event of an accident. Additionally, oxygen tanks contain a highly pressurized gas that vigorously accelerates combustion. These factors could lead to serious injury or death to the user and/or anyone else in the vehicle.

- When using this wheelchair as a seat in a motor vehicle, you must remove any items attached to the vent tray, battery tray or oxygen tank holder and properly secure them separately.
- If the chair is equipped with an oxygen tank holder never use the wheelchair as a seat in a motor vehicle.

NOTE: To obtain copies of RESNA or ISO standards please contact the standards organizations below:

RESNA

www.resna.org

ANSI/RESNA Standards:

RESNA WC-4, Section 18:

Wheelchair tie-down and occupant restraint systems for use in motor vehicles.

RESNA WC-4, Section 19:

Wheelchairs used as seats in motor vehicles.

RESNA WC-4, Section 20:

Wheelchair seating systems for use in motor vehicles.

International Organization for Standardization (ISO)

www.iso.org

ISO Standards:

ISO 10542-1 Technical systems and aids for disabled or handicapped persons -- Wheelchair tie-down and occupant-restraint systems -- Part 1:

Requirements and test methods for all systems.

ISO 16840-4 Wheelchair seating – Part 4:

Seating systems for use in motor vehicles.

ISO 7176-19 Wheelchairs – Part 19:

Wheeled mobility devices for use as seats in motor vehicles.

IV. WHEELCHAIR USE & CONFIGURATION

E. Cushion Use

WARNING

WARNING: Avoid sitting for long periods of time without a proper wheelchair cushion. Sitting for long periods of time without a proper wheelchair cushion could cause pressure ulcers which could lead to serious infections or even death.



Secure the cushion before use or transfer. Failure to secure a cushion can cause it to slide out during use or transfers, resulting in a fall or loss of control. A fall or loss of control could result in damage to your chair or in serious injury or death to you or others.

- a. This wheelchair was designed to be used with a proper wheelchair cushion.
- b. The standard sling upholstery is provided with hook and loop self fastening strips. The cushion being used should have hook type fasteners that can engage the loop of the seat sling to keep the cushion from sliding out from under you. Ensure the cushion is securely attached before transferring or sitting in the wheelchair.
- c. A standard seat sling may not have been provided with your chair. Check with your wheelchair provider if an aftermarket replacement to the original equipment sling has been provided. If so, make sure you follow the instructions for use provided by the aftermarket manufacturer.

IV. WHEELCHAIR USE & CONFIGURATION

F. Your Arc & Its Parts

1. Inspect and maintain your chair using information found in the Maintenance and Care section.
2. If you detect a problem, contact your authorized supplier immediately.

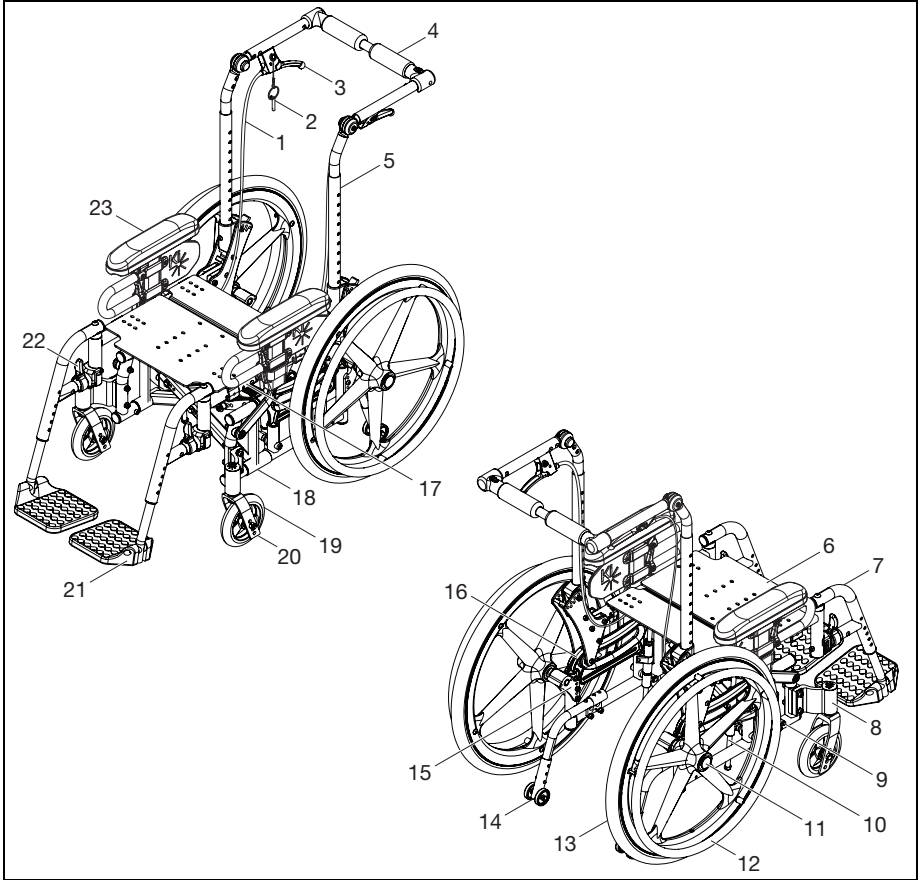

- | | |
|------------------------|-----------------------------|
| 1. Tilt Cable | 13. Rear Wheel |
| 2. Trigger Lock Pin | 14. Anti-Tip |
| 3. Tilt Lock Trigger | 15. Axle Plate |
| 4. Push Handle | 16. Roller Guide |
| 5. Back Cane | 17. Seat Frame |
| 6. Seat Pan | 18. Base Frame |
| 7. Swing Away Hanger | 19. Caster Wheel |
| 8. Caster Housing | 20. Caster Fork |
| 9. Wheel Lock | 21. Footplate |
| 10. Mechlock | 22. Swing Away Lever |
| 11. Quick Release Axle | 23. Height Adjustable T-Arm |
| 12. Handrim | |

IV. WHEELCHAIR USE & CONFIGURATION

G. Folding and Unfolding the Wheelchair

How to Fold Your Wheelchair

1. Remove any seating, seat pan and backrests.

NOTE: The hangers and armrests can also be removed for a smaller profile once the chair is fully folded.

2. If present, disconnect the folding angle adjustable handle or folding rigidizer bar. See Fig. 2.

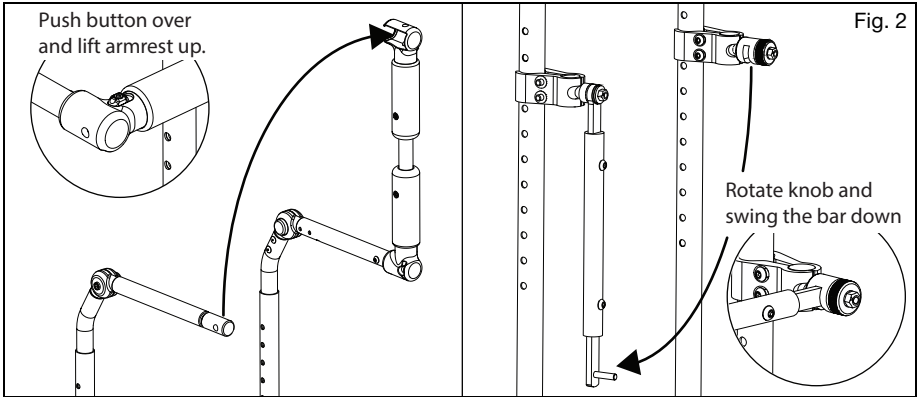

3. Begin the folding process by pulling up on the folding loop with two fingers at the Folding Strap. The Folding Strap is not designed as a carrying strap. See Fig. 3.

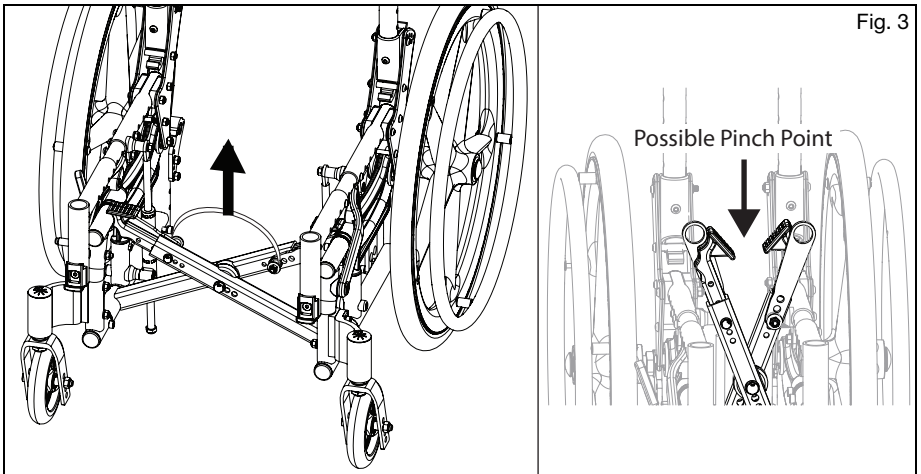

IV. WHEELCHAIR USE & CONFIGURATION

G. Folding and Unfolding the Wheelchair (Continued)

4. With a folding backrest, the backrest canes can be folded down by pushing the canes forward while pushing the latch levers (Fig. 4:A).

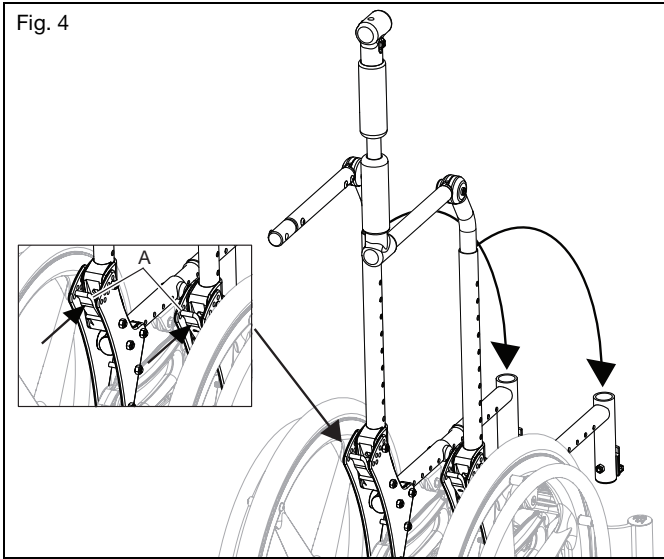

How to Unfold Your Wheelchair

1. If the back canes are folded down, lift up until you hear the latch levers click into place.
2. Pull both sides of the chair apart and push down on the extension cross brace pad (Fig. 5:A) to ensure the cross braces are in place.

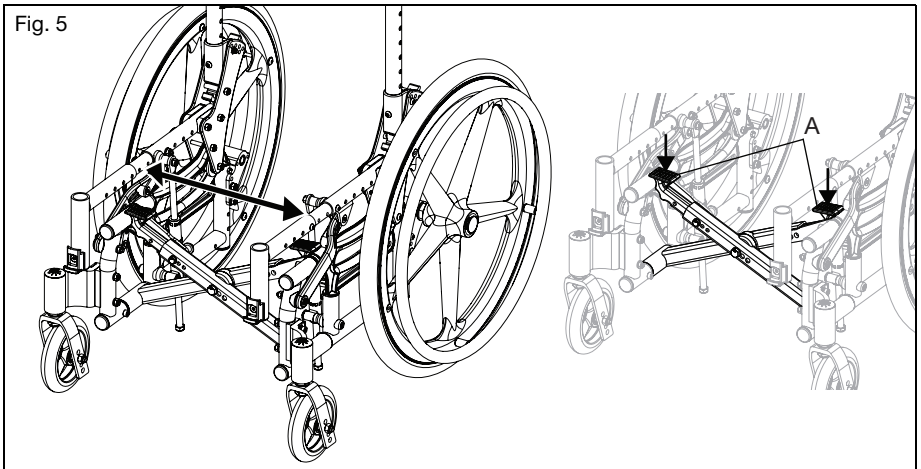

3. Reinstall any seating, seat pan, backrest, armrests and hangers that were taken off before folding the chair.

IV. WHEELCHAIR USE & CONFIGURATION

H. Height Adjustable T-Arm

WARNING

WARNING: These arms offer only a lock against rotation and are designed to bear a downward force only. They will remove completely if pulled up on and cannot be used to lift or otherwise handle the chair. Failure to comply with the instructions above may result in the armrest accidentally disconnecting from the wheelchair and result in a fall or loss of control and may cause serious injury or death.

How to Use Your Armrest

1. Installation
 - a. Slide the outer armpost into the receiver mounted to the wheelchair frame.
 - b. The armrest will automatically lock into place. Check to make sure the locking lever is as shown (Fig. 6:B).
2. Height Adjustment
 - a. Rotate the release lever (Fig. 6:A).
 - b. Slide the armrest pad up or down to the desired height.
 - c. Return the lever to the locked position against the arm post.
 - d. Push the arm pad until the upper arm locks firmly into place. Check to make sure the locking lever is as shown (Fig. 6:A).
3. Removing the Armrest
 - a. Squeeze the release lever (Fig. 6:B) and remove the armrest.

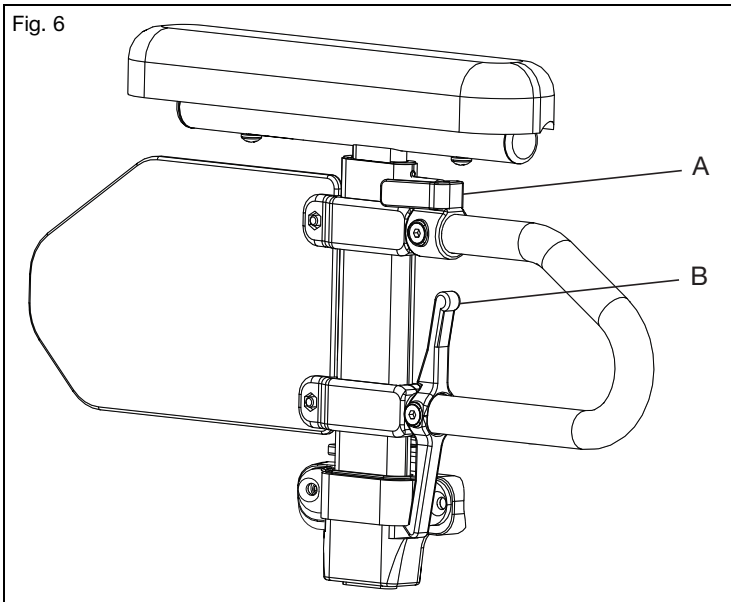

IV. WHEELCHAIR USE & CONFIGURATION

I. Pediatric T-Arm

WARNING

WARNING: These arms offer only a lock against rotation and are designed to bear a downward force only. They will remove completely if pulled up on and cannot be used to lift or otherwise handle the chair. Failure to comply with the instructions above may result in the armrest accidentally disconnecting from the wheelchair and result in a fall or loss of control and may cause serious injury or death.

How to Use Your Armrest

1. Installing the Armrest
 - a. Slide the armrest into the receiver on the side frame. Ensure the pin in lever engages the receiver (Fig. 7).
2. Removing the Armrest
 - a. Push the lever (Fig. 7:A) in towards the side guard panel to release the pin from the receiver.
 - b. Pull the armrest straight out of the receiver.
3. Adjusting the Arm Height in the Receiver
 - a. Remove the armrest from the chair.
 - b. Remove two 6mm screws from the side guards (Fig. 7:B).
 - c. Remove M4 screw (Fig. 7:C) from the side guard post stop through the side guard post but do not remove entirely. The screw can stay in the lever assembly. Repeat on the other arm.
 - d. Reset the post stop and the lever assembly on the side guard post to desired position. Retighten M4 screw (Fig. 7:C). Repeat on the other arm.
 - e. Place the side guard in the desired position and replace two 6mm screws (Fig. 9:B) to secure the side guard in place. Tighten two 6mm screws. Repeat on the opposite arm.
 - f. Replace the armrest assemblies into the receiver (Fig. 7).

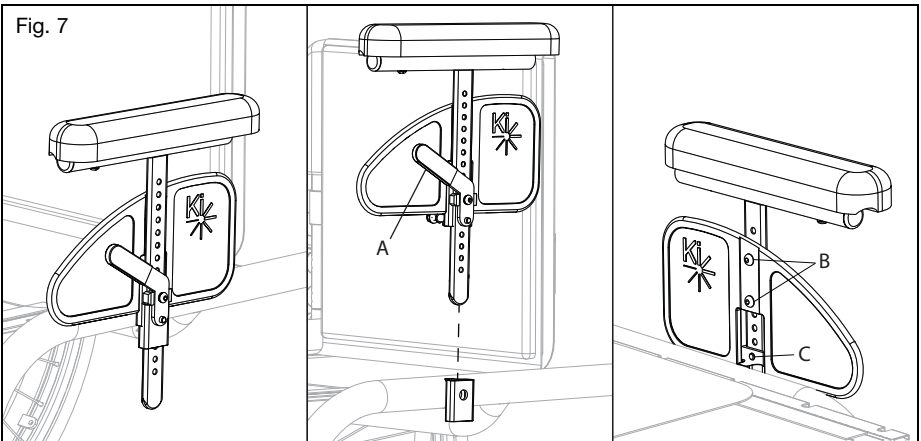

IV. WHEELCHAIR USE & CONFIGURATION

J. Angle Adj. Locking Extendable Flip Up Armrest

WARNING

WARNING: These arms offer only a lock against rotation and are designed to bear a downward force only. They will remove completely if pulled up on and cannot be used to lift or otherwise handle the chair. Failure to comply with the instructions above may result in the armrest accidentally disconnecting from the wheelchair and result in a fall or loss of control and may cause serious injury or death.

How to Use Your Armrest

1. Flip the Armrest Up
 - a. Press the release lever (Fig. 8:A) up to release the armrest.
 - b. Swing the released armrest up.
2. Return the Armrest to Operating Position
 - a. To return the armrest to the operating position, push the armrest down until the lever clicks and locks.

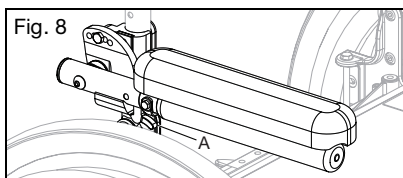

K. Swing Away Hangers

WARNING

WARNING: Ensure the hangers are locked into place before using or riding the wheelchair. Unlocked hangers during use can cause a fall resulting in serious injury or death.

 **Avoid tripping or falling during a transfer. Ensure your feet do not get caught in the space between the footrests and avoid putting weight on the footrests as the chair may tip forward and cause a fall resulting in a serious injury or death.**

How to Use Your Hangers

1. Installation
 - a. Place swing away pivot saddle into the receiver on the front frame tube with the footrest facing inward or outward from the frame (Fig. 9).
 - b. Rotate the footrest so it aligns with the frame and locks into place in the latch block (Fig. 10).

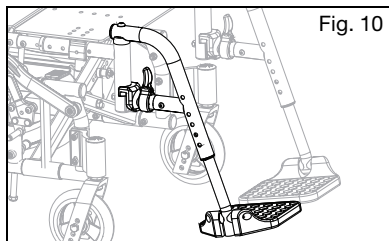
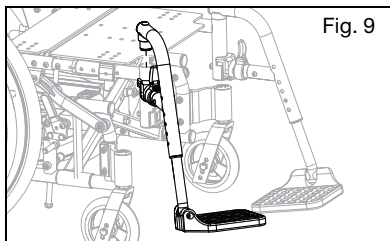

IV. WHEELCHAIR USE & CONFIGURATION

K. Swing Away Hangers (Continued)

2. Swinging the Footrest Away
 - a. Push the release latch toward the frame.
 - b. Rotate the footrest outward or inward as desired.
3. Removal
 - a. To remove the footrest, push the release latch toward the frame.
 - b. Lift the footrest straight upward to remove. You may also swing the footrest inward or outward before lifting it off.

L. Swing Away Hangers with 4-Way Latch



WARNING

WARNING: Ensure hangers are locked in place before using wheelchair. Unlocked hangers while using the wheelchair could cause a fall resulting in serious injury or death.



Avoid tripping or falling during a transfer. Ensure your feet do not get caught in the space between the footrests and avoid putting weight on the footrests as the chair may tip forward and cause a fall resulting in a serious injury or death.

How to Use Your Hangers with 4-Way Latch

1. Installation
 - a. Place the swing away pivot saddle into the receiver on the front frame tube (Fig. 11:A)
 - b. Rotate the footrest so that it aligns with the frame and locks into place in the latch block (Fig. 11:B).
2. Swinging the Footrest Away
 - a. Push or pull on the release latch.
 - b. Rotate the footrest outward or inward as desired.
3. Removal
 - a. To remove the footrest, push or pull the release latch.
 - b. Lift the footrest straight upward to remove. You may also swing the footrest inward or outward before lifting it off.

Fig. 11

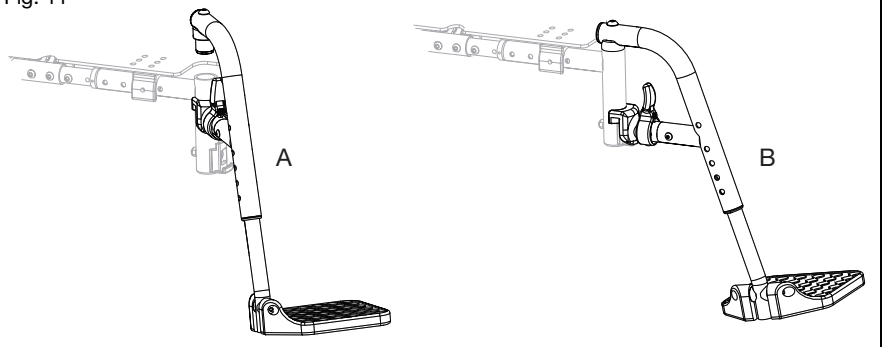

IV. WHEELCHAIR USE & CONFIGURATION

M. Extension Tubes



WARNING: Ensure hangers are locked into place before using or riding the wheelchair. Unlocked hangers during use can cause a fall resulting in serious injury or death.

How to Adjust the Extension Tubes

1. Remove the mounting fasteners from each side of the hanger tube.
2. Slide the footrest extension tube to the desired height.
3. Line up the holes and reassemble the fasteners into the desired hole through the hanger and the extension tube.
4. Repeat steps 1 - 3 on opposite side (Fig. 12).

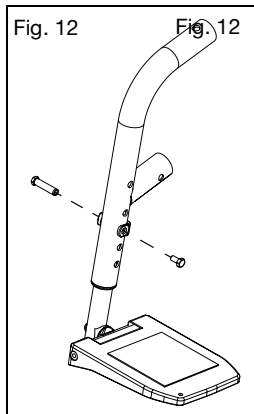

N. Elevating Leg Rest



WARNING: Ensure hangers are locked in place before using wheelchair. Unlocked hangers while using the wheelchair could cause a fall resulting in serious injury or death.



Avoid tripping or falling during a transfer. Ensure your feet do not get caught in the space between the footrests and avoid putting weight on the footrests as the chair may tip forward and cause a fall resulting in a serious injury or death.

How to Use the Elevating Leg Rest

1. Installing the Elevating Leg Rest
 - a. Place the swing away pivot saddle into the receiver on the front frame tube with the footrest facing either inward or outward from the frame. Similar to the swing away footrest pictured in Fig. 11.
 - b. Rotate the footrest so it aligns with the frame until it locks into place in the latch block.
2. Removing the Elevating Leg Rest
 - a. To remove the footrest, push or pull the release lever.
 - b. Rotate the footrest outward and lift.

IV. WHEELCHAIR USE & CONFIGURATION

N. Elevating Leg Rest (Continued)

3. Adjusting the Extension Tube
 - a. Remove the mounting bolt that is threaded into the leg rest tube in the center of the pad bracket (Fig. 13:C). In some circumstances, this bolt may be inserted in the tube below the pivot bracket.
 - b. Slide the footrest extension tube to the desired height.
 - c. Line up the holes and replace the bolt through the leg rest tube and the extension tube.
 - d. Repeat steps a - c on opposite side.
4. Adjusting the Angle of the Leg Rest
 - a. To raise, lift up on the rear of the extension tube (Fig. 13:A). The rod will slide through the ratchet in this direction. Stop at the desired position.
 - b. To lower, firmly hold the leg from behind the extension tube (Fig. 13:A). Pull forward on the lever (Fig. 13:B) and while holding the lever, lift the leg rest. Releasing the lever will cause the leg rest to lock into position.

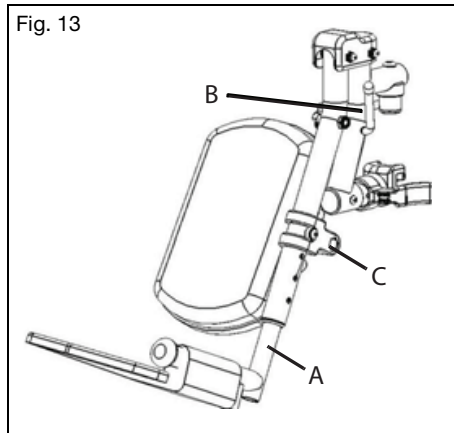

O. Pro Elevating Leg Rest

⚠ WARNING ⚠

WARNING: Ensure hangers are locked in place before using wheelchair. Unlocked hangers while using the wheelchair could cause a fall resulting in serious injury or death.



Avoid tripping or falling during a transfer. Ensure your feet do not get caught in the space between the footrests and avoid putting weight on the footrests as the chair may tip forward and cause a fall resulting in a serious injury or death.

How to Use the Pro Elevating Leg Rest

1. Installing the Pro Elevating Leg Rest
 - a. Place the swing away pivot saddle into the receiver on the front frame tube with the leg rest facing either inward or outward from the frame. Similar to the swing away footrest pictured in Fig. 11.
 - b. Rotate the leg rest so that it aligns with the frame and locks into place in the latch block.

IV. WHEELCHAIR USE & CONFIGURATION

O. Pro Elevating Leg Rest (Continued)

2. Adjusting the Height of the Calf Pad
 - a. Loosen nut (Fig. 14:A) using a 10mm wrench.
 - b. Slide the calf pad arm up or down to the desired location.
 - c. Retighten the nut.
3. Adjusting the Depth of the Calf Pad
 - a. Remove the screw (Fig 14:B) and nut (Fig. 14:C) on the calf pad arm using a 5mm Allen wrench and a 13mm wrench.
 - b. Pick the desired location based on the four predrilled holes and reinstall the screw and nut.

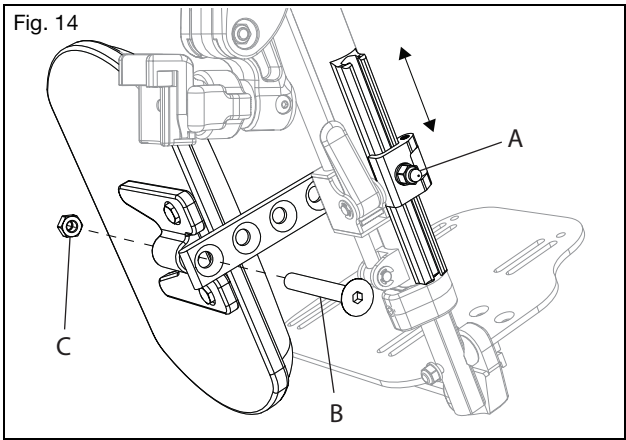

4. Adjusting the Length of Footrest
 - a. Loosen the set screw (Fig. 15:A) with a 4mm Allen wrench.
 - b. Slide the extension tube in or out to get to the desired length and secure by tightening the set screw.

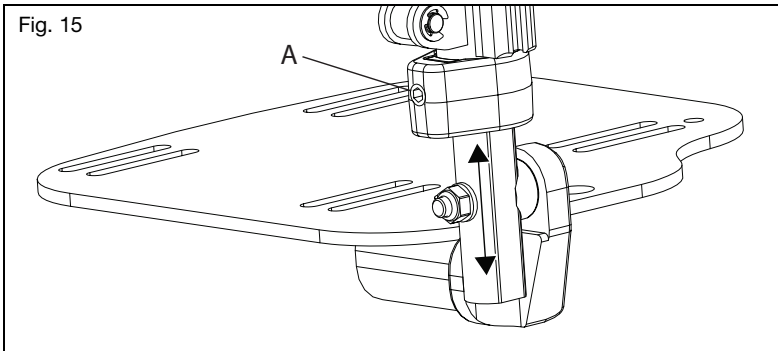

IV. WHEELCHAIR USE & CONFIGURATION

O. Pro Elevating Leg Rest (Continued)

5. Raising/Lowering the Pro Elevating Leg Rest

Remove the Pro ELR from the chair or remove weight from the Pro ELR while lowering to avoid a sudden drop when the lever lock is pushed. The calf pad can also swing outward to clear the front of the chair during certain movements if necessary.

- To raise the Pro ELR, lift the leg rest tube (Fig. 16:A) to the desired angle of elevation.
- To lower the Pro ELR, press and hold the lever lock (Fig. 16:B) while pushing the leg rest tube (Fig. 16:A) down.
- Retighten the nut.

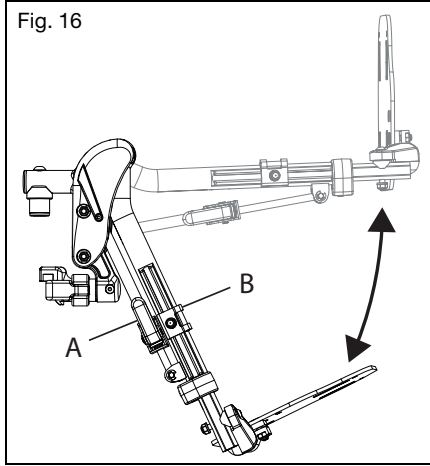

6. Adjusting the Knee Height

- Use two 10mm socket wrenches to loosen the nuts (Fig. 17:A) on the cover.
- Adjust the knee height to the desired setting.
- Retighten the nuts to secure the knee height.

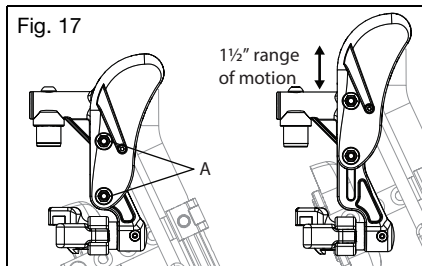

7. Removing the Pro Elevating Leg Rest

- To remove the leg rest, push or pull the release latch.
- Lift the leg rest straight upward to remove. You may also swing the leg rest inward or outward before lifting it off.

IV. WHEELCHAIR USE & CONFIGURATION

P. Pediatric Elevating Leg Rest

WARNING

WARNING: Ensure hangers are locked in place before using wheelchair. Unlocked hangers while using the wheelchair could cause a fall resulting in serious injury or death.

 **Avoid tripping or falling during a transfer. Ensure your feet do not get caught in the space between the footrests and avoid putting weight on the footrests as the chair may tip forward and cause a fall resulting in a serious injury or death.**

How to Use the Pediatric Elevating Leg Rest

1. Installing the Pediatric Elevating Leg Rest
 - a. Place the swing away pivot saddle into the receiver on the front frame tube with the leg rest facing either inward or outward from the frame. Similar to the swing away footrest pictured in Fig. 11.
 - b. Rotate the leg rest so that it aligns with the frame and locks into place in the latch block.
2. Adjusting the Height of the Calf Pad
 - a. Loosen nut (Fig. 18:D) using a 10mm wrench.
 - b. Slide the calf pad arm up or down to the desired location.
 - c. Retighten the nut.
3. Adjusting the Depth of the Calf Pad
 - a. Remove the screw (Fig. 18:C), washer (Fig. 18:B) and nut (Fig. 18:A) on the calf pad arm using a 5mm Allen wrench and a 13mm wrench.
 - b. Pick the desired location based on the four predrilled holes and reinstall the screw and nut.

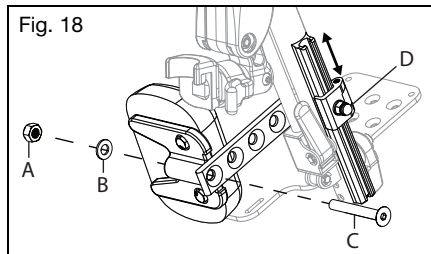

4. Adjusting the Knee Height
 - a. Use two 10mm socket wrenches to loosen the nuts (Fig. 19:A) on the cover.
 - b. Adjust the knee height to the desired setting.
 - c. Retighten the nuts to secure the knee height.

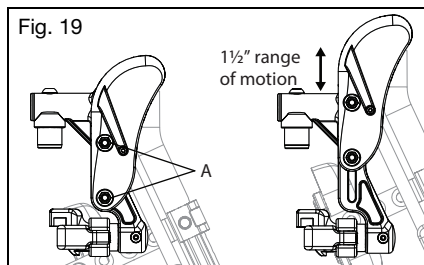

IV. WHEELCHAIR USE & CONFIGURATION

P. Pediatric Elevating Leg Rest (Continued)

5. Using the Pediatric Elevating Leg Rest

Remove the Pediatric Pro ELR from the chair or remove weight from the Pediatric Pro ELR while lowering to avoid a sudden drop when the lever lock is pushed.

- a. To raise, lift the leg rest tube (Fig. 20:A) to the desired angle of elevation.
- b. To lower, press and hold the lever lock (Fig. 20:B) while pushing the leg rest tube (Fig. 20:A) down.

6. Removing the Pediatric Elevating Leg Rest

- a. To remove the leg rest, push or pull the release latch.
- b. Lift the leg rest straight upward to remove. You may also swing the leg rest inward or outward before lifting it off.

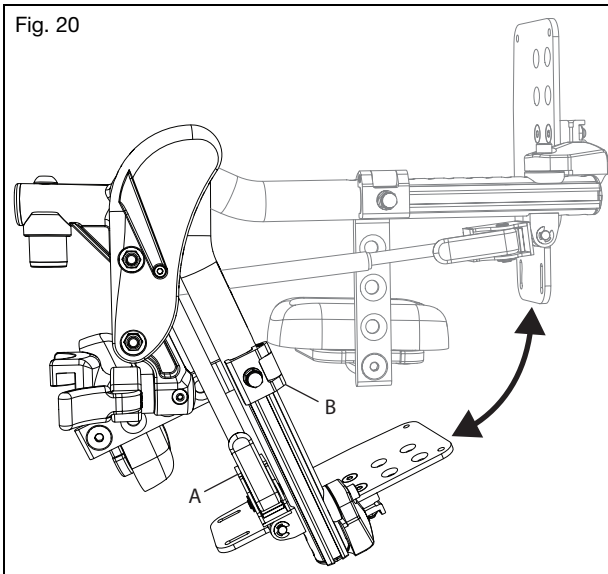

IV. WHEELCHAIR USE & CONFIGURATION

Q. Contracture Footrest

⚠️ WARNING ⚠️

WARNING: Ensure hangers are locked in place before using wheelchair. Unlocked hangers while using the wheelchair could cause a fall resulting in serious injury or death.

⚠️ **Avoid tripping or falling during a transfer. Ensure your feet do not get caught in the space between the footrests and avoid putting weight on the footrests as the chair may tip forward and cause a fall resulting in a serious injury or death.**

How to Use the Contracture Footrest

Fig. 21 shows the contracture footrest in the outside mount configuration. A center mount configuration can be achieved by moving the leg rests to the opposite side.

1. The footrests can be angled toward the chair and away from the chair by simply adjusting at the upper pivot point (Fig. 21:A).
2. The footplates on a contracture footrest can also be moved front to rear (Fig. 21:B), can change the angle (Fig. 21:C) and can be flipped up for transfer (Fig. 21:D).

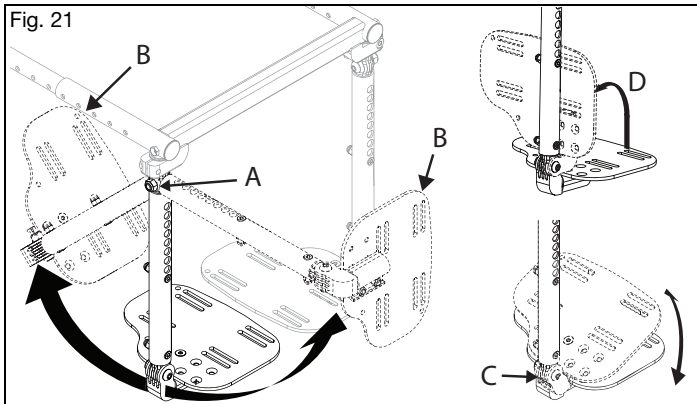

IV. WHEELCHAIR USE & CONFIGURATION

R. Multi-Angle Footrest

1. Changing Footrest Angle (Fig. 22)

The Multi-Angle Footrest utilizes a ball joint which allows the footrest to be set in a variety of angles just by applying pressure to different areas on the top of the footplate.

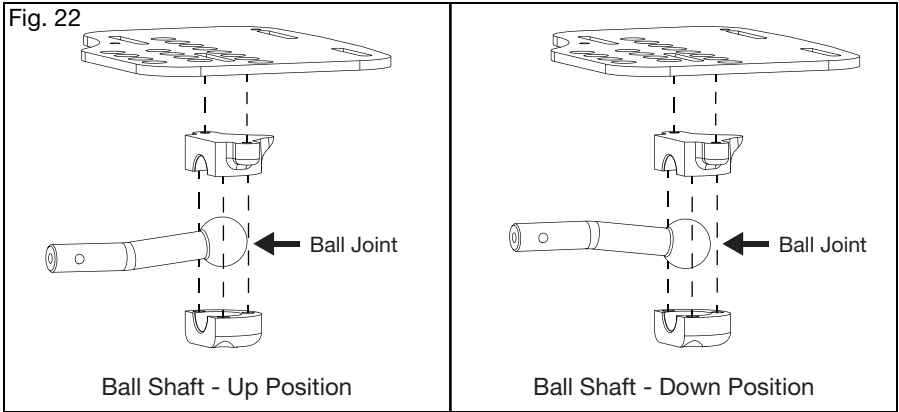

2. Changing Footrest Height

a. Remove footplate assembly from hanger by removing screw (Fig. 23:G), washer (Fig. 23:F), washer (Fig. 23:E), saddle spacer (Fig. 23:D), washer (Fig. 23:C), washer (Fig. 23:B) and nut (Fig. 23:A) using a 5mm Allen wrench and a 10mm wrench.

b. Slide the footplate assembly to desired height and reinstall hardware in nearest hole.

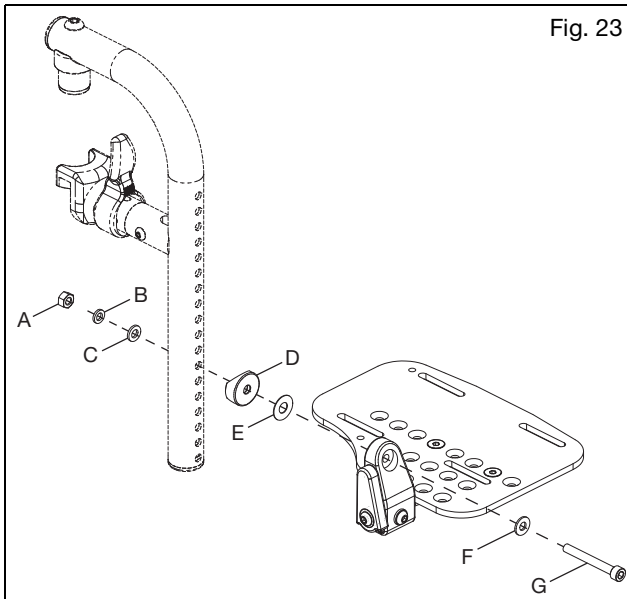

IV. WHEELCHAIR USE & CONFIGURATION

S. Backrest

How to Fold the Backrest Down

1. Push the levers (Fig. 24:A) toward the front of the chair to disengage the latches. If the backrest seating is attached, both latches must be disengaged simultaneously in order to allow the backrest to fold.
2. Push forward on the backrest to rotate it downward. Once it begins to rotate forward the latch levers may be released.

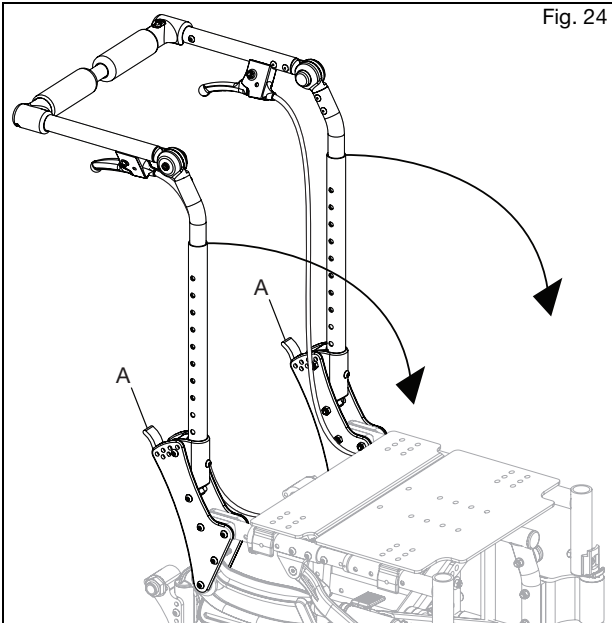

IV. WHEELCHAIR USE & CONFIGURATION

S. Backrest (Continued)

How to Adjust a Push Handle Angle

1. If the chair is equipped with a height adjustable backrest, push the buttons of the locking hinges (Fig. 25:A). Both of the buttons must be pressed simultaneously to adjust the angle.
2. While holding the buttons down, rotate the push handle to the desired position.
3. Release the buttons when the desired angle is achieved.
4. Verify that the hinge is locked by pulling upwards on the push handles.

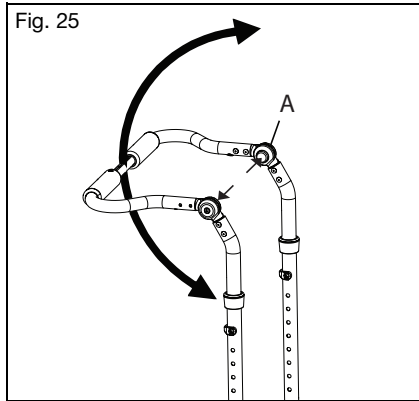

How to Remove a Stroller Handle

1. Depress the buttons (Fig. 26:A) on both sides of the chair toward the lower end of the stroller tubes to disengage the locking tabs.
2. Pull the handle out of the receivers to remove or push the stroller handle into the receivers to install. For best results, insert both sides at the same time.

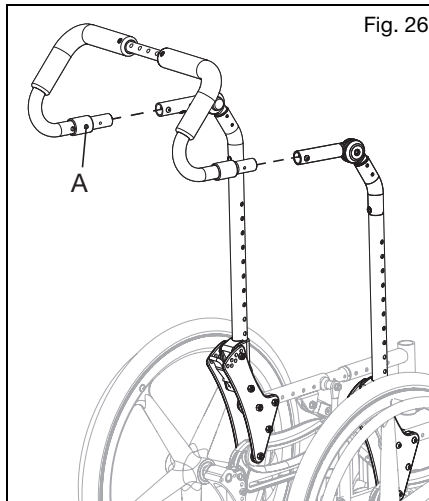

IV. WHEELCHAIR USE & CONFIGURATION

T. Reclining Backrest

How to Recline and Incline the Backrest

NOTE: Fig. 27 is showing the hand tilt configuration. Fig 28 is showing the foot tilt configuration.

1. To unlock the system prior to the recline or incline adjustment, remove the locking pin (Fig. 27:A) from the locking hole (Fig. 27:B) on each recline trigger.
2. Ensure wheel locks are engaged and the wheelchair is on a level surface.
3. Grip the handles securely and slowly depress both reclining triggers (Fig. 28:A) at the same time to release the gas cylinders. This will allow you to adjust the backrest position as follows:
 - a. Reclining - to open the angle of the backrest relative to the seat frame, or recline, apply downward force on the gas springs.
 - b. Inclining - return to the upright position by applying force upward and pushing the backrest towards the front of the backrest.
4. Once the desired backrest recline angle has been achieved, slowly release both of the reclining triggers.
5. To lock the system, insert the locking pin into the locking pin hole. It is recommended that you always lock both reclining backrest triggers when you are done positioning the patient.

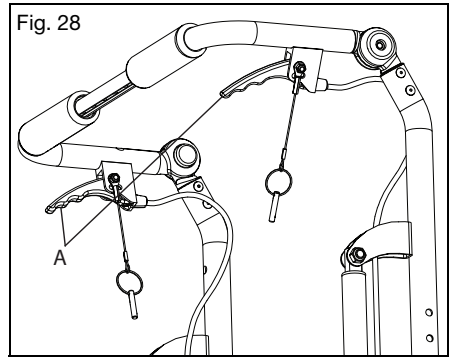
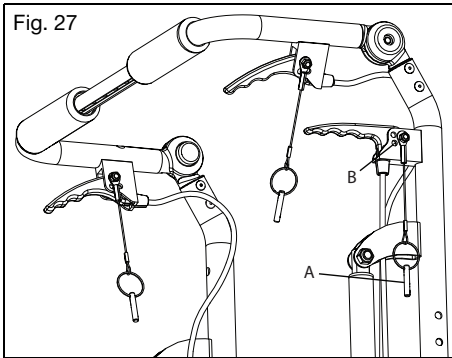

IV. WHEELCHAIR USE & CONFIGURATION

U. Tilt Mechanism

⚠️ WARNING ⚠️

WARNING: Do not leave an occupied chair unattended with the triggers secured in an unlocked position. Leaving someone in a chair unattended with the triggers secured in an unlocked position could cause a tip-over resulting in serious injury or death.

⚠️ CAUTION ⚠️

CAUTION: Ensure hands are clear from moving components along the side of the chair when tilting to avoid potential pinch points. Not avoiding potential pinch points may result in injury.

How to Use the Hand Operated (Trigger) Tilt

1. Tilting the Seat Frame
 - a. Squeeze the trigger or triggers (Fig. 29:A).
 - b. While keeping the trigger(s) depressed, rotate the seat frame to the desired position.
 - c. Release the trigger(s) to lock into place.
2. Adjusting the Tilt Cable
 - a. Unlock the jam nut (Fig. 29:C) from the cable adjuster body (Fig. 29:D) using a 10mm and 3/8" open ended wrench.
 - b. Thread the cable adjuster (Fig. 29:B) in or out until the slack in the cable is eliminated, but also so the cogs are still fully seated in the teeth of the rotary frames.
 - c. Verify the function of the cable. The tilt mechanism should lock at all locations and the cogs should not drag along the teeth at any location. If the cogs drag or if there is excessive play in the triggers, the cable adjuster must be unthreaded more. If the cog is disengaged from the teeth at all, the adjuster must be threaded onto the body further.
 - d. Once the cable is adjusted and the function is verified, lock the jam nut against the cable adjuster body by tightening the nut only, not the adjuster or the adjuster body.

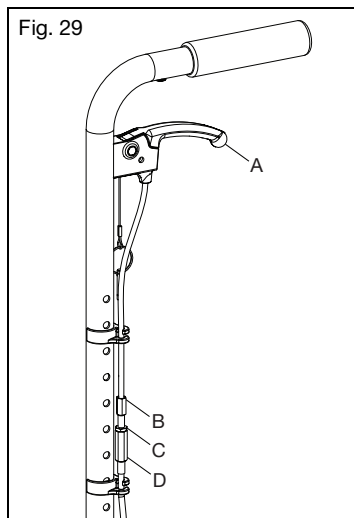

IV. WHEELCHAIR USE & CONFIGURATION

U. Tilt Mechanism (Continued)

3. Locking the Triggers

- a. Determine which style back canes and trigger were provided with the chair by checking the images in Fig. 30 & 31.
- b. Ensure the chair is locked by pushing on the back handles.
- c. Insert the pin, attached to the trigger by a lanyard, into the hand trigger hole (Fig. 30:A & 31:A).
- d. Ensure the trigger no longer releases the tilt locks by gently squeezing the trigger and pushing on the back canes to tilt the chair.

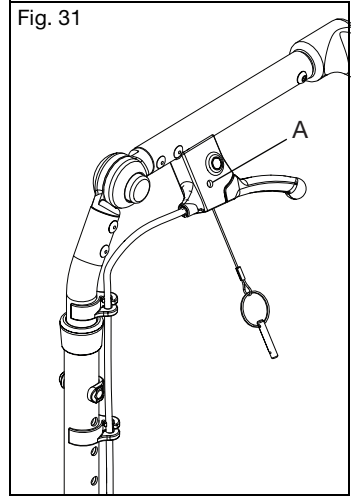
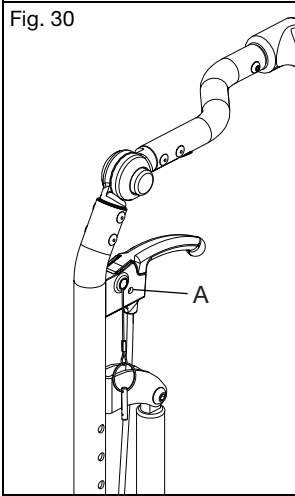

IV. WHEELCHAIR USE & CONFIGURATION

U. Tilt Mechanism (Continued)

Using the Foot Operated Tilt

1. Tilting the Seat Frame
 - a. Depress the foot pedal (Fig. 32:C).
 - b. Tilt the seat frame to the desired position while keeping the pedal depressed.
 - c. Release the pedal to lock into place.
2. Adjusting the Cables
 - a. Use two 10mm wrenches to loosen the jam nut (Fig. 32:B) while holding the adjuster (Fig. 32:A) in place. Repeat on the opposite cable.
 - b. Adjust the cable by turning the adjusters until the desired tension is obtained. Ensure the actuators on the mech locks are not being actuated while the pedal is released and the mech locks slide freely when the pedal is depressed.
 - c. Once the desired tension is obtained and tested to be functioning properly, hold the adjusters in place with the wrench and tighten the jam nut. Repeat on the opposite cable.

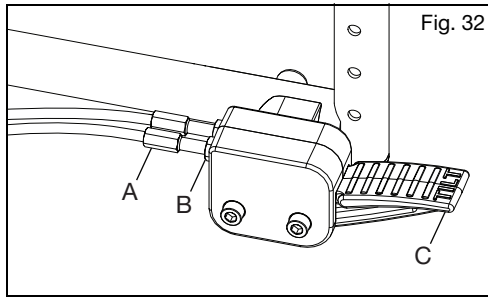

Using the Tilt Stops

1. Remove the screws from the tilt stops and install onto the shaft of the mech lock. Reinstall the screws, but do not tighten (Fig. 33:A). Repeat for opposite mech lock.
2. Set the chair to the desired angle that the tilt would like to be limited to.
3. For limiting rearward tilt, slide the tilt stop to the bottom of the mech lock body and tighten into the place. For limiting forward tilt, the tilt stops may be placed above the body of the mech lock (Fig. 33:B). When the desired angle is achieved, slide the tilt stop against the top of the mech lock body and tighten.
5. Ensure both of the tilt stops are against their respective mech locks simultaneously.

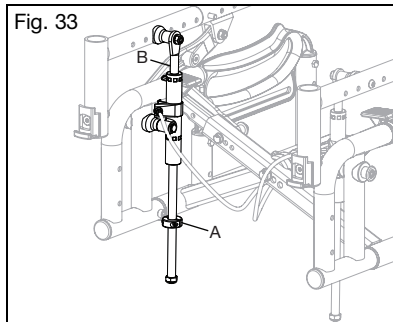

IV. WHEELCHAIR USE & CONFIGURATION

V. Rear Wheels



WARNING: Before operating chair, assure the push button is completely extended and locking balls on the inside are fully engaged. Failure to do so may result in the wheel falling off, which could cause a fall or tip-over resulting in serious injury or death to you or others.

How to Use Your Rear Wheels

1. Installing the Wheels

- a. Push in the quick release button (Fig. 34:B) on the axle (Fig. 34:C) to allow the locking balls to retract. Make note of the difference between the extended and depressed position of the axle release button and its effect on the locking balls (Fig. 34:D) on the other end of the axle.
- b. Insert the axle into the bearing housing on the wheel if it's separate.
- c. Push on the quick release button again and slide the axle into the axle sleeve (Fig. 34:A).
- d. Release the button to lock the axle in sleeve. If the release button does not fully extend and the locking balls do not move into the locked position after releasing the button, the axle length needs to be adjusted.
- e. If the wheel does not fit, try installing it on the opposite side.

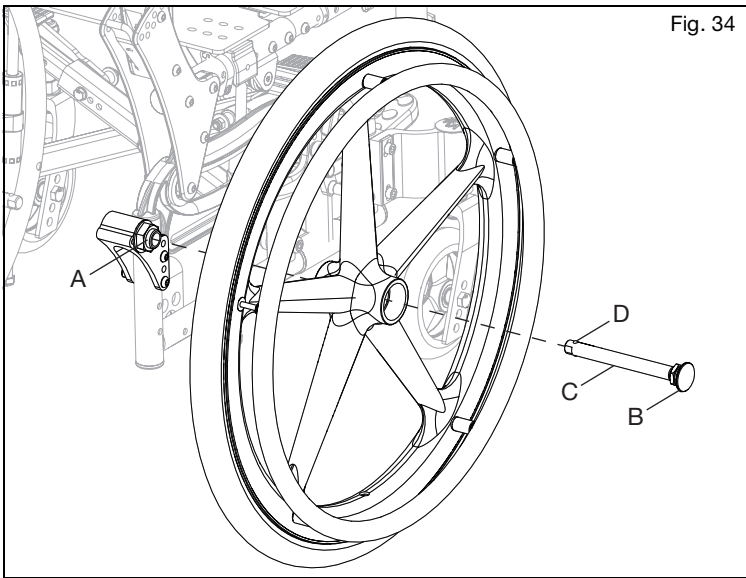

2. Removing the Wheels

- a. Hold the wheel close to the hub and push the button in on the outside end of the axle.
- b. While still holding the button, pull the wheel and the axle out of the axle sleeve.

IV. WHEELCHAIR USE & CONFIGURATION

W. Wheel Locks

WARNING

WARNING: Underinflated or worn tires may cause your wheel locks to not function properly. Failure of the wheel locks to hold your chair could cause a loss of control or fall resulting in serious injury or death.

1. Adjusting Wheel Locks

- a. Use a 10mm wrench or socket to loosen (do not remove) hex bolt (Fig. 35:A) that is located on the inside of the chair frame..
- b. Slide wheel lock assembly forward or rearward to achieve proper locking.
- c. Retighten hex bolt.

Fig. 35

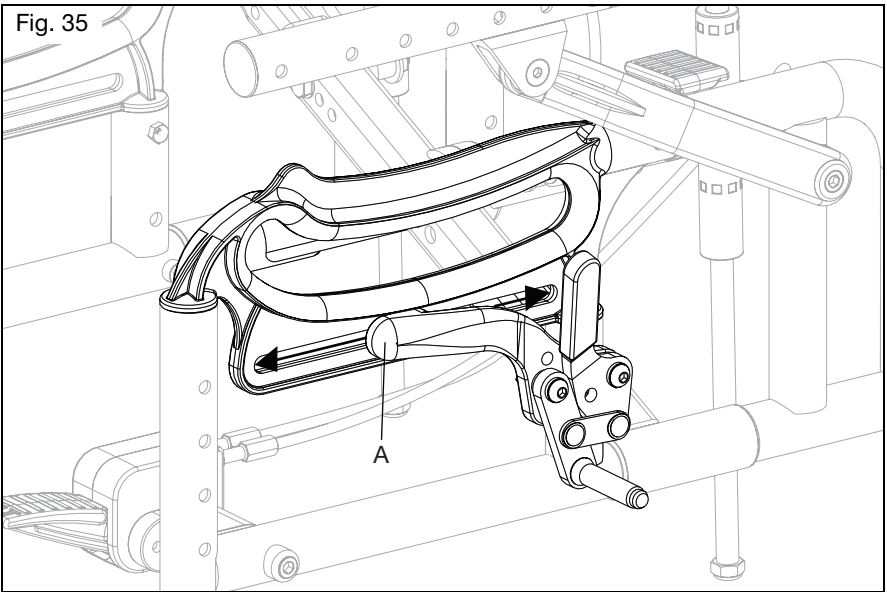

IV. WHEELCHAIR USE & CONFIGURATION

X. Drum Brake

How to Use Your Drum Brakes

1. Using the Drum Brakes

- a. Squeeze the brake levers (Fig. 36:B) on both sides of the chair to activate the brakes. Each side is operated independently and may be squeezed with more or less force to get more or less braking action.
- b. Let go of the brake levers to release the brake.
- c. For the parking brake function, squeeze each brake lever and, while trigger is squeezed, use your index finger to flip the locking lever (Fig. 36:A) down into the teeth on the lever mount. While holding the locking lever down, release the brake handles and the parking brake will remain engaged.
- d. To release the parking brake, squeeze the brake levers until the spring loaded locking levers snap back. Release the brake levers to deactivate the brake.

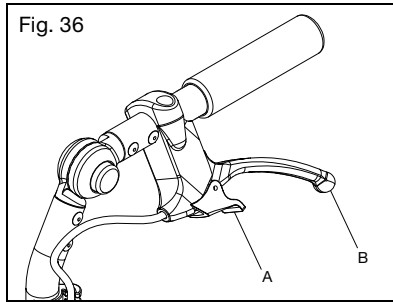

2. Adjusting the Drum Brakes

- a. Use a 10mm wrench to unlock the jam nut (Fig. 37:B) on the adjuster (Fig. 37:A). Unthread the adjuster to get tighter braking action or thread the adjuster in to reduce the braking action.

NOTE: The recommended brake configuration will have a slight bit of drag on the wheel when spun. Thread the adjuster inward about 1/2 turn, or whatever is necessary to remove all drag from the spinning wheel.

- b. Retighten the jam nut to lock the adjustment in place. Repeat on the opposite side of the chair.

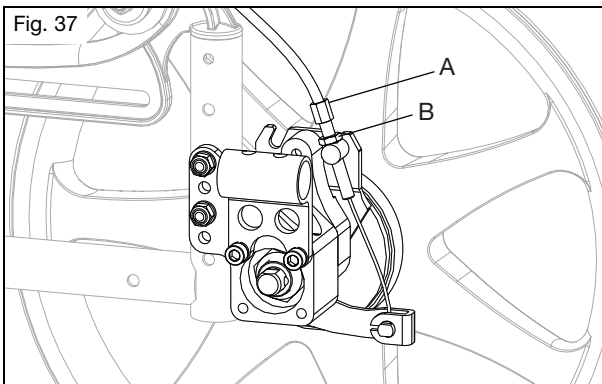

IV. WHEELCHAIR USE & CONFIGURATION

Y. Attendant Foot Lock

How to Use Your Attendant Foot Lock (Fig. 38)

1. To engage, the attendant steps onto the foot lever until it locks down.
2. To disengage, the attendant steps onto the foot lever and pushes down slightly until the foot lever pops up and releases.

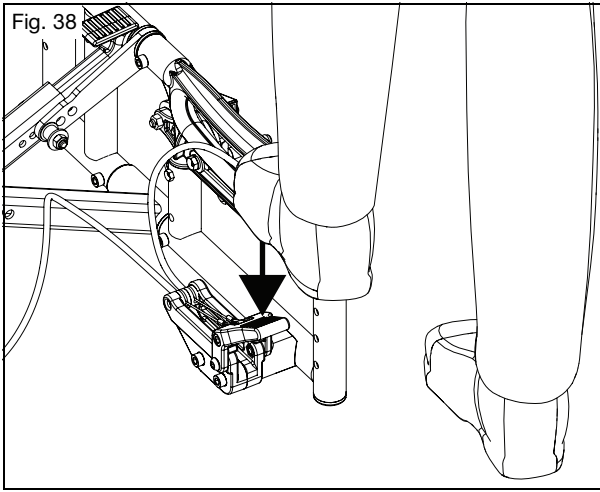

Z. Surface Temperature

⚠ WARNING ⚠

WARNING: Handling of wheelchair surfaces with elevated temperatures can result in a potentially hazardous situation which, if not avoided, could result in injury.

Be aware that prolonged exposure to direct sunlight or other sources of radiant heat may increase the temperature of surfaces on your wheelchair above recommended limits estimated by standards.

IV. WHEELCHAIR USE & CONFIGURATION

AA. Anti-Tips

WARNING

WARNING: Always keep anti-tips in the down position when they are not at risk of interference. Have a clinical or technical professional confirm your anti-tips are installed in the correct position. They can do so by tipping the occupied wheelchair back on to the anti-tips to test that they properly limit the rearward rotation of your wheelchair. If the anti-tips allow your wheelchair to tip to a point where your center of gravity (COG) is vertically aligned with the point where the wheel contacts the ground, the wheelchair is unstable and could result in the wheelchair tipping over. Tipping over could result in damage to your wheelchair, serious injury or death.

 New and experienced wheelchair users switching to a new wheelchair or adjusting the configuration of a current wheelchair should always use anti-tips. If the user has a change in physical capabilities, they should use anti-tips as well. Any change in the user's physical capabilities or wheelchair increases the risk of tipping over backwards. Tipping over backwards could result in damage to your wheelchair, serious injury or death. You should always use anti-tips until you have adapted to the new or adjusted wheelchair.

 Remove or turn the anti-tips up when ascending or descending curbs, obstacles and steps. If the anti-tips are left in the down position when ascending or descending curbs, obstacles and steps, they can become bent or broken. If the anti-tips are bent or broken, they will no longer prevent the wheelchair from tipping over backwards. Tipping over backwards could result in damage to your wheelchair, serious injury or death.

 Using your wheelchair on soft surfaces (including but not limited to sand, loose soil, grass and gravel), uneven grades and ramps can cause anti-tips to lose effectiveness resulting in the wheelchair tipping over backwards. Tipping over backwards could result in damage to your wheelchair, serious injury or death.

 Ki mobility recommends using two anti-tips on your wheelchair. Use of a single anti-tip increases the risk of tipping over backwards. Tipping over backwards could result in damage to your wheelchair, serious injury or death.

Ki Mobility recommends using anti-tips with your wheelchair. Anti-tips help prevent your wheelchair from tipping over backwards. When adjusted properly, anti-tips provide a significant increase in rearward stability. Use of anti-tips does not guarantee your wheelchair will not tip over. Always remember to reinstall or turn the anti-tips to the down position after they were removed or turned to the up position.

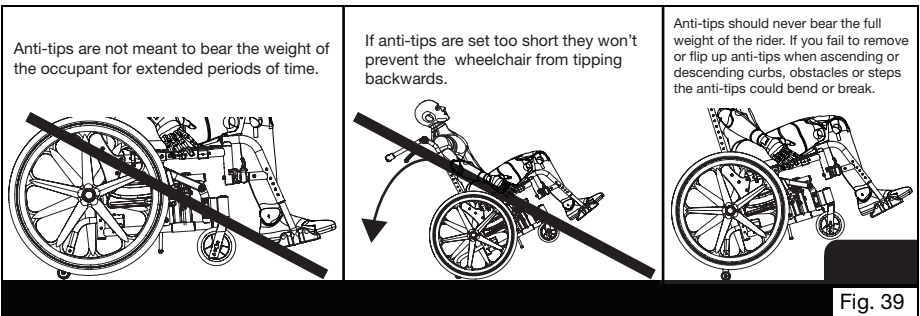

Fig. 39

IV. WHEELCHAIR USE & CONFIGURATION

AA. Anti-Tips (Continued)

How to Install the Standard Anti-Tips (Fig. 40)

1. Press the rear anti-tip release pin (Fig. 40:A) on the anti-tip tube so both the release pins are drawn inside.
2. Insert the anti-tip tube into the receiver mounted on the camber tube.
3. Turn the anti-tip tube down until the release pin is positioned through the receiver mounting hole.
4. Insert the second anti-tip tube the same way.

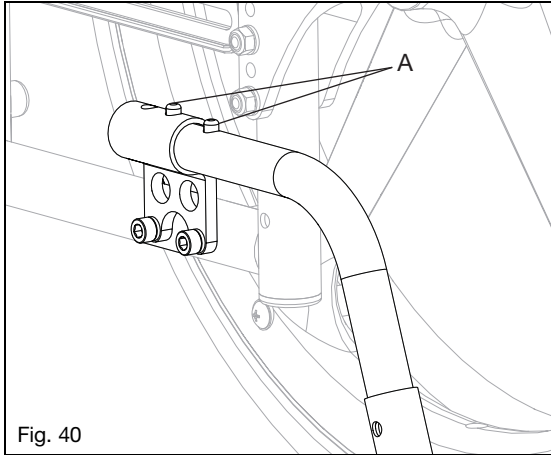

How to Adjust the Wheel Extension Height (Fig. 41)

1. Press the anti-tip wheel release pin so the release pin (Fig. 41:A) is drawn inside.
2. Raise or lower the anti-tip to any of the predrilled holes.
3. Release the pin.
4. Adjust the second anti-tip tube wheel the same way. Both of the wheels should be at exactly the same height.

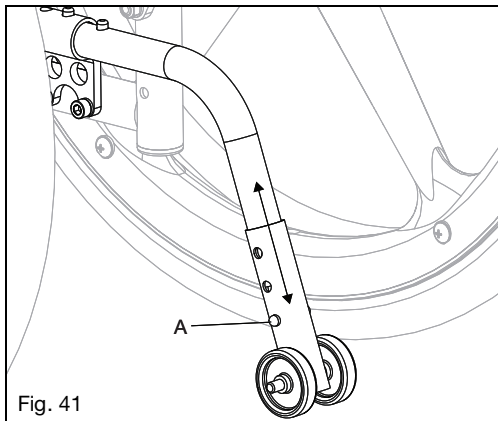

IV. WHEELCHAIR USE & CONFIGURATION

AA. Anti-Tips (Continued)

How to Turn the Anti-Tip Tubes Up (Fig. 42)

1. Press the rear anti-tip tube release pin (Fig. 42:A).
2. Hold the pin in and turn the anti-tip tube up.
3. Release the pin.
4. Repeat with the second anti-tip tube.
5. Return the anti-tip tubes to the down position after completing the maneuver.

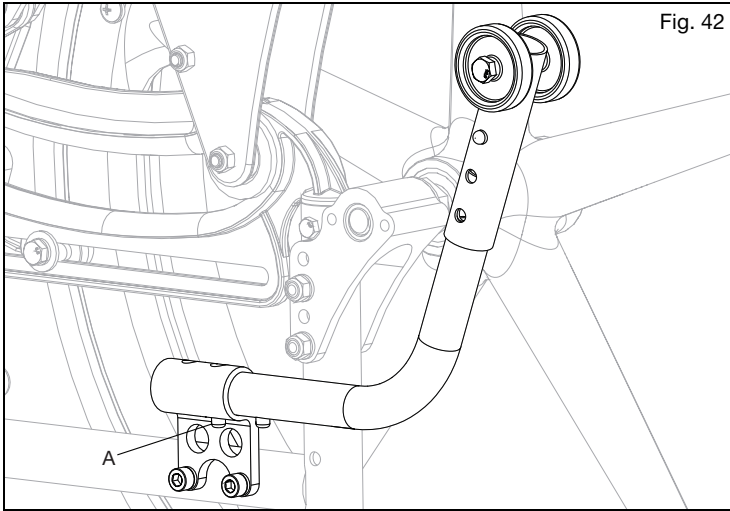

IV. WHEELCHAIR USE & CONFIGURATION

BB. Hemi Wheel Lock

Identify Master (Drive) Side and Follower Side

The master (drive) side has the wheel lock with the handle for activating the brake. In Fig. 43, the master (drive) side is shown on the right side of the chair.

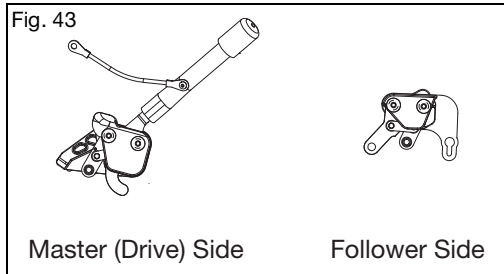

Adjusting the Locks (See Fig. 44)

1. Ensure the wheel lock mount is loose enough to move freely.
2. Set the wheel lock assemblies into the locked position with the knurled bar barely contacting the tire.
3. With the bolts loosened, slide the assemblies toward the tires in 1/4" increments until the chair can be lifted by the wheels with locked tires without the wheels rotating.
4. Verify the master lock assembly wheel lock can enter the over-center position when in the locked position and the follower lock assembly wheel lock can return to the unlocked position.

NOTE: Some configurations such as spoke wheels with pneumatic tires may show initial interference with the follower assembly. To fix, move the threaded adjustment on the cable rearward which allows you to shift the wheel lock forward while retaining the same locking force.

5. Tighten the bolts that connect the master and follower lock assemblies to the wheel lock mounts to 50 in/lbs using a 4mm Allen wrench.
6. Fully tighten the bolts connecting the wheel lock assemblies to the chair frame.
7. The threaded adjustment on the follower side should be set so the follower side linkage does not bottom out.

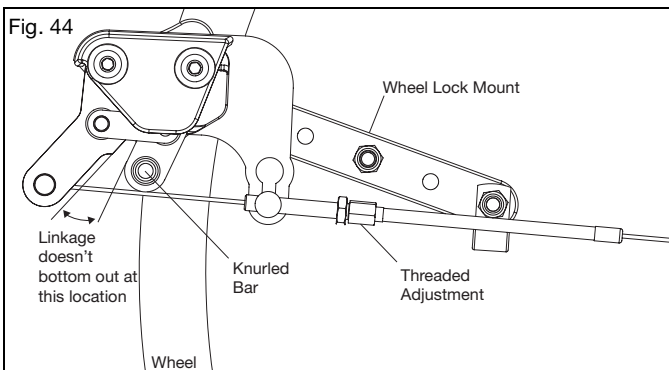

IV. WHEELCHAIR USE & CONFIGURATION

CC. Canopy

How to Use the Canopy

1. Folding the Canopy (Fig. 45:A)
 - a. To close, lift the front end of the canopy and take the front end all the way to the back end and fold the canopy out of the way.
 - b. To open, take the front end of the canopy and pull out and down until the canopy is fully stretched out.
2. Quick Removal and Quick Install (Fig. 45:C)
 - a. Push in the latches (Fig. 45:D) on both sides of the canopy and lift up and out of the receivers.
 - b. To reinstall the canopy, install both ends into the receivers until the latches catch the bottoms of the tube mount clamps and "lock" into place.
3. Rain Catch (Fig. 45:B)
 - a. The edge of the canopy will fold up to catch and direct rain away from the chair user.

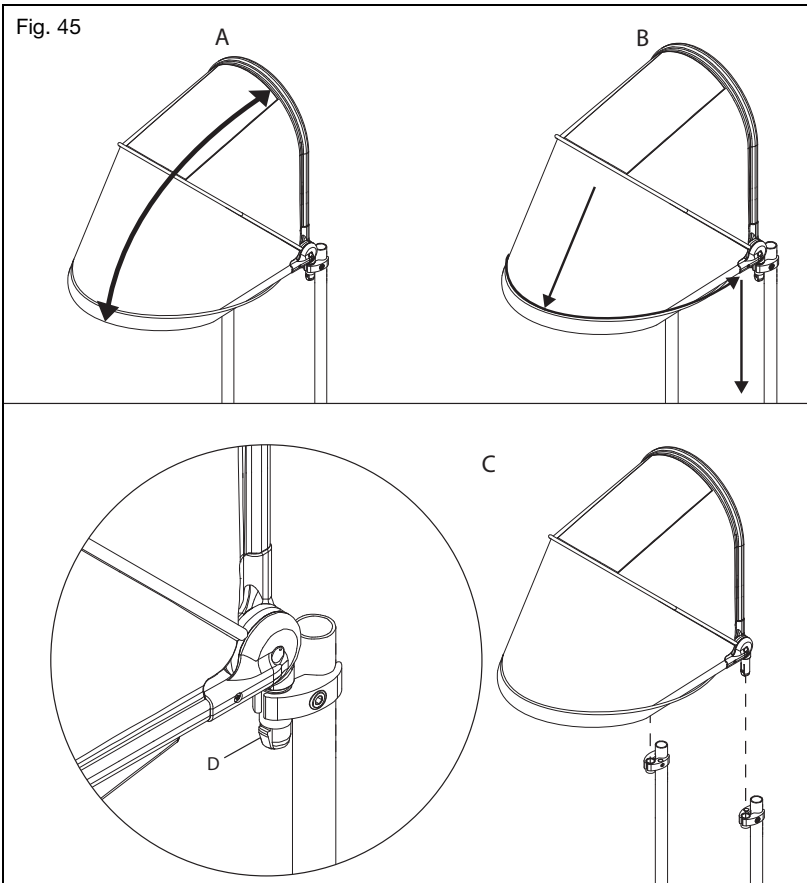

IV. WHEELCHAIR USE & CONFIGURATION

DD. Folding Adjustable Handle

How to Use the Folding Adjustable Handle

1. Push the release button (Fig. 46:A) and lift the handle upwards.
2. Reengage the handle by pushing the handle down until the release button clicks and locks into place.

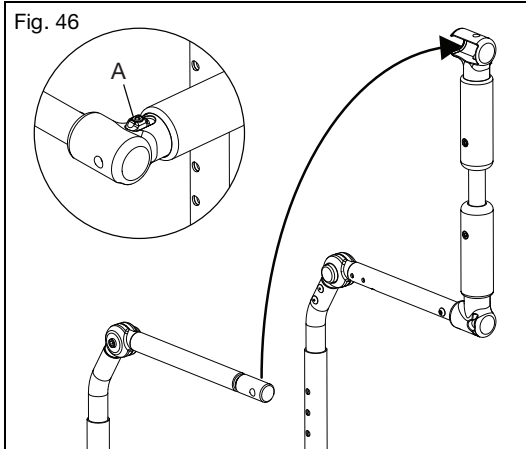

EE. Folding Rigidizer Bar

How to Use the Folding Rigidizer Bar

1. Rotate the release knob (Fig. 47:A) and swing the rigidizer bar downward.
2. Reengage the rigidizer bar by swinging the bar upward until it is in the space behind the release knob.
3. Secure in place by tightening the release knob.

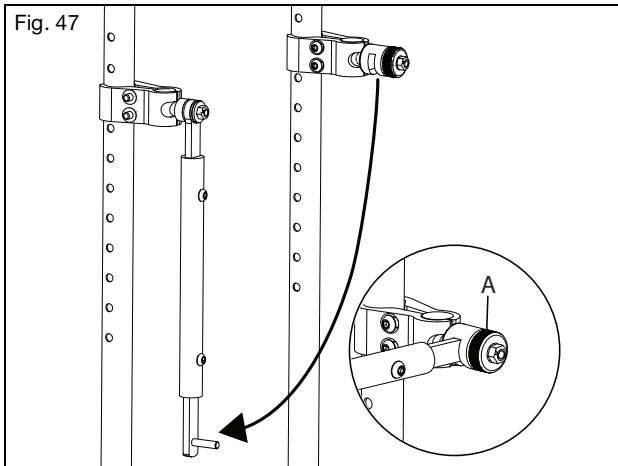

V. MAINTENANCE AND CARE

A. Maintenance Table

Regular and routine maintenance will extend the life of your wheelchair while improving its performance. Wheelchair repairs, the replacement of parts and any maintenance check that you are not comfortable performing should be done by an authorized supplier. Only use Ki Mobility approved parts when replacing components.



CAUTION: Do not use petroleum-based solvents, degreasers or dewatering agents (including but not limited to automotive cleaners, alcohols or WD-40). Damage to components, bearings or finishes may occur.

Check	Weekly	Monthly	Annually
Check the tire inflation levels and inflate as needed. The correct inflation levels are found on the tire.	✓		
Check wheel lock engagement and disengagement. Tire pressure changes and tire wear will require the wheel locks to be adjusted. Wheel lock adjustment instructions can be found in the Wheel Locks section of this manual.	✓		
Check the axle sleeves and axle plates to ensure the axle sleeve nuts are tight.	✓		
Check that quick release axles engage and disengage properly.	✓		
Check that caster wheels, anti-tip wheels and rear wheels spin freely. Cleaning or replacement parts may be needed if there are any issues.	✓		
Clean area around the caster housing and bearings. This is a common location for hair build up.	✓		
Clean your wheelchair. In the event of corrosive spills or exposure to biohazards, remove contaminants immediately. See the Cleaning section in this manual for instructions.	✓		
Check the rear tires, anti-tip wheels and the caster wheels for wear spots or damage. Replace immediately if needed.	✓		
Check handrims to ensure they are secure and not damaged.	✓		
Check that the hand grips do not rotate or pull off. Replace if needed.	✓		
Check armrest receivers for loose or missing fasteners and check they are secure, adjusted properly and maintain position.	✓		
Wipe the rotary frame glide surfaces with a damp cloth.	✓		
Test tilt cable function and visually inspect the cable for correct routing (See the Tilt Mechanism section), harsh bends and kinks.	✓		
Confirm all cables and handles release and return properly if present.	✓		
Check that anti-tips are level and functional.	✓		
Visually inspect the roller bearings for signs of wear or damage.		✓	
Inspect the frame(s) and anti-tips for deformities, defects, cracks, dimples or bends. These could be signs of fatigue in the wheelchair which could result in a failure. Discontinue use of the wheelchair immediately and contact an authorized supplier.		✓	
Check upholstery for signs of wear, fraying or holes. Replace upholstery immediately if needed.		✓	
Check arm pads, cushions and back rest for damage, rips or tears.		✓	
Check wheels for any loose, broke or bent spokes. Replace immediately if needed.		✓	
Check that all fasteners are tight. Unless otherwise noted, fasteners should be tightened to 40 in./lbs (4.51 N*m).		✓	
Verify the wheelchair rolls easily and straight.		✓	
Have the wheelchair checked and adjusted by a qualified technician at your authorized supplier.			✓

V. MAINTENANCE AND CARE

B. Cleaning



CAUTION: Washing upholstered components containing flame retardants, as indicated on the labeling of the upholstery, may reduce the flame retardants' efficacy over time. This may increase the risk of ignition when exposed to open flame or other ignition sources, which may increase the risk of injury.

Axles, Wheels, Tires and Moving Parts:

1. Clean around the axles and wheels weekly with a damp rag.
2. Hair and lint will lodge in and around the caster housing and rear wheel axles. Remove with a stiff brush or pick. Take care not to damage bearing seals.

Painted Surfaces

1. Hand wash using a cloth and mild detergent.
2. Dry using a clean cloth or allow wheelchair to air dry.
3. Nonabrasive wax may be used to help preserve painted surfaces.

Upholstery:

1. Hand wash using a cloth and mild detergent.
2. Allow upholstery to air dry. **DO NOT** machine dry.

Plastic Components

1. Hand wash using a cloth and mild detergent.
2. Do not use solvents or aggressive cleaners as they may damage plastic components.

Sanitizing

1. Disinfect surfaces with over the counter disinfecting sanitizer of at least 70% alcohol or wipes. Do not soak or allow pooling of cleaning solutions.
2. Allow sanitizer to remain on surface for at least 15 minutes and remove with aseptic cloth.

C. Storage

1. When not in use, keep your chair in a clean, dry area. Failure to do so may result in your chair rusting and/or corroding.
2. If your chair has been in storage for more than two months, it should be serviced and inspected by an authorized supplier before use.

V. MAINTENANCE AND CARE

D. Disposal

The construction of wheelchairs' and the Ki Power Tilt System poses no known hazards in preparation for disposal or materials that present a biohazard for disposal. Damage to the RCB-10 control box could result in battery acid leakage. Take precaution and wear hand and eye protection when handling is necessary.

Specific waste disposal or recycling regulations may be in force locally and these should be taken into consideration when disposal arrangements are made. This may include the cleaning or de-contamination of the wheelchair before disposal.

If recycling of materials is a requirement, please refer to the following list of general materials used in the components of the wheelchair:

- Aluminum - Frame, caster fork, caster mount, bearing housing, camber tube assembly, backrest mount plates, backrest frame, backrest release bar, push handles, footrest tubes, footplate, seat rails, handrim and wheel rim.
- Steel - Fasteners, QR axles, caster stems, backrest release latch, wheel spokes, bearings and axle sleeve.
- Plastic - Rear wheels, caster tires, push handle grips, armrest pads and tube plugs.
- Upholstery - Woven polyester fabric and polyurethane foam.

If recycling of materials is desired or a requirement, such as per Directive 2012/19/EU, WEEE (Waste Electrical and Electronic Equipment) in Europe, both REAC and Mascot are compliant to WEEE and provide guidance on recycling and disposal. Proper dismantling is necessary to achieve a high proportion of reuse or recycle. Care to use proper tools and protective measures in handling are required to avoid contact with sharp edges.

Plastics marked with recycling symbols and thermoplastic parts can be recycled. Aluminum, copper and steel parts, including fasteners, may be recycled. Cables, batteries and PCB are to be disposed separately per local requirements.

Return your chair and accessories to your authorized supplier for proper disposal if you are not comfortable or able to dispose of your wheelchair properly.

VI. TROUBLESHOOTING

A. Symptoms and Solutions

For optimum performance, your wheelchair needs to be adjusted occasionally. The following is a list of potential symptoms you may encounter over the life of your wheelchair and the suggested solutions for each symptom. For best results when troubleshooting, try one solution at a time before proceeding to a second solution. If symptoms are not relieved or you are not confident in performing the solution, it is recommended to take the wheelchair to an authorized service center for repair.

Solutions:

A - Self Correct if capable or contact Authorized Distributor

B - Contact Authorized Distributor

		Symptoms							
		Chair pulls to one side	Looseness in chair	Difficulty turning	Caster Float	Caster Flutter	Squeaking, clicking or rattling	Difficulty Tilting	
Solutions	B	Add spacer washer between caster stem and bottom caster housing bearing on left or right side of chair.	X				X		
	A	Ensure all tire pressures are correct and equal.	X		X	X			
	A	Check to make sure all fasteners are tightened appropriately, tighten if necessary.	X	X	X	X	X	X	X
	B	Ensure cable/foot tilt mechanism is adjusted.		X			X		X
	A	Check to make sure casters are contacting the ground and float is not present.	X		X		X		
	B	Optimize CG setting.			X		X		
	A	Check for interference at rear wheel and front casters.	X		X			X	
	A	Lubricate w/Teflon based lubricant between frame connections and mating parts in suspect areas.						X	
	A	Remove caster/bearing debris.	X		X		X		

VII. WARRANTY

Ki Mobility warrants the frame and quick-release axles of this wheelchair against defects in materials and workmanship for the life of the original purchaser. All other Ki Mobility-made parts and components of this wheelchair are warranted against defects in materials and workmanship for one year from the date of first consumer purchase.

The expected life of the frame is five years.

Limitations to the Warranty

1. We do not warrant:
 - a. Wear items: Upholstery, tires, armrest pads, tubes, armrests and push-handle grips.
 - b. Damage resulting from neglect, misuse or from improper installation or repair.
 - c. Damage from exceeding weight limit.
2. This warranty is VOID if the original chair serial number tag is removed or altered.
3. This warranty is VOID if the original chair has been modified from its original condition and it is determined the modification resulted in failure.
4. This warranty applies in the USA only. Check with your supplier to find out if international warranties apply.

Ki Mobility's Responsibility

Ki Mobility's only liability is to replace or repair, at our discretion, the covered parts. There are no other remedies, expressed or implied.

Your Responsibility

- a. Notify Ki Mobility, via an authorized supplier, prior to the end of the warranty period and get a return authorization (RA) for the return or repair of the covered parts.
- b. Have the supplier send the authorized return, freight pre-paid, to:
Ki Mobility
5201 Woodward Drive
Stevens Point, WI 54481
- c. Pay any charges for labor to repair or install parts.



Ki Mobility
5201 Woodward Drive
Stevens Point, Wisconsin 54481
715-254-0991



www.kimobility.com



DCN0653.1