



MOTION
COMPOSITES



FOLDING
CARBON

VELOCE | FOR A STYLISH, ACTIVE LIFESTYLE



FOR A STYLISH, ACTIVE LIFESTYLE

The VELOCE by Motion Composites is a technologically advanced wheelchair for active users. Offering unrivaled agility, lightness, stability and responsiveness, this folding chair promises both performance and comfort. Featuring the all-important benefits of a compact folding system, the VELOCE is easy to transport and adjust to your preferences. In short, it adapts to your active lifestyle.

World-renowned, Motion Composites uses its know-how and its passion for innovation to design unique, cutting-edge products inspired by you. As a visionary and passionate company, our ambition is driven by your experience.

We believe that high-performance wheelchairs enhance people's lives with components, design, features and quality. VELOCE is our passion for performance, our commitment to quality and our vision of greater freedom brought to life.

GO BEYOND!



reddot design award
winner 2019



Model/Ambassador: Joel Dembe



ULTRALIGHT AND ADJUSTABLE

- 12 lb. — Carbon fiber for lightness
- Nearly unlimited adjustment options

Manufactured with the highest quality standards, the frame is designed using carbon fiber layers making it incredibly light. The 12 lb. transport weight includes the foldable footrest due to the frame's design making it even lighter. In addition to being incredibly strong, the VELOCE model is fully adjustable for a personalized fit. It offers a vast and competitive range of front and rear seat-to-floor heights, various seat angle and center of gravity adjustments for a tailored fit. We are proud to say that this chair is one of the lightest and most practical folding models on the market.

PRACTICAL AND COMFORTABLE

- Simplifies your everyday life
- The ease of a folding chair, the comfort of a rigid chair

Easy transfers, easy transport, the VELOCE wheelchair is perfect for active users. The innovation behind this model gives it the performance and convenience of a folding chair with the comfort and stability of a rigid chair. The Veloce's Mantis frame fuses a box frame in the back for enhanced rigidity with a cantilever frame in the front for a minimalist look and flexibility. It is easy to take along wherever you want to go and once unfolded and ready, offers exceptional handling. No need to take the footplates off thanks to the award-winning auto folding footrest. Whether you are traveling by car or plane, the Veloce delivers one of the practical and lightest wheelchair available.

BOLD DESIGN AND STYLE

- Unique Mantis frame
- Attractive, minimalist design

With its spirited Mantis frame—closed in the back and open in the front—its signature triangular tubing and carbon finish with elegant color accents, VELOCE's sleek, avant-garde and aesthetically pleasing look turns heads and instills a sense of pride.

“ I have been so happy with my Veloce wheelchair, it fits into my lifestyle perfectly. Since using it, it has given me the confidence to start my own YouTube channel *Wheelsnoheels*, where I show others that you can have a happy and fulfilling life being a wheelchair users. My wheelchair has traveled all over the world with me including a solo trip from London to LA. My wheelchair has become a part of me, and I'm proud to have it as part of my identity. ”

— Gem Hubbard, UK

MANEUVERABILITY AND EASE OF PROPULSION

- Your energy is taking you further
- Efficient, agile, responsive

Ease of propulsion is an undeniable plus and, with the VELOCE, you'll enjoy remarkable agility. The completely symmetrical hydroformed cross brace maximizes the frame's stability, saving you considerable energy on a daily basis to make every push counts.

FEATURES

RIGID UNIBODY FRAME

Eliminates joints, reduces movement and maximizes efficiency

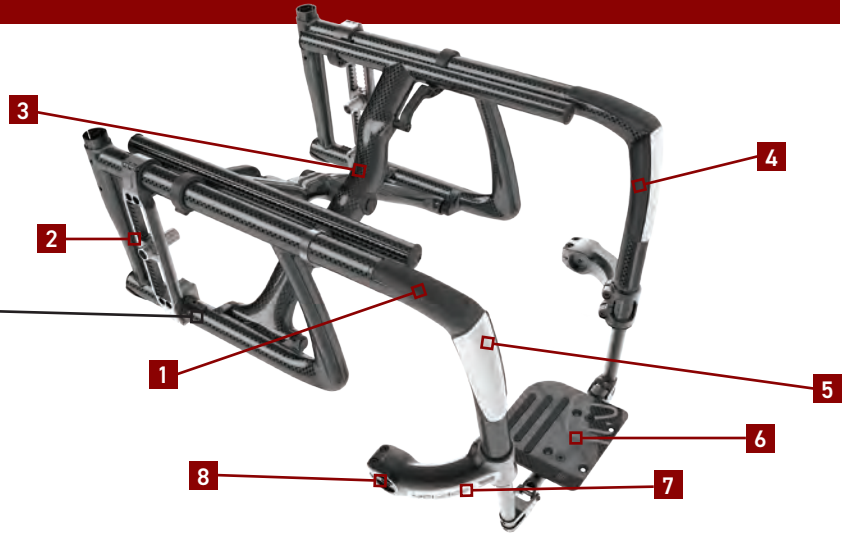

1 RUBBERIZED HAND GRIP
To facilitate transfers



2 INNOVATIVE REAR WHEEL AXLE PLATE
Offers micro adjustments while maximizing stability and responsiveness



3 ULTRARIGID FOLDING SYSTEM
Offers best-in-class propulsion efficiency



4 INTEGRATED PAD
Provides more comfort and avoid pressure points on the knees



5 INTEGRATED IMPACT GUARD
Protects the front frame from wear and tear



6 AUTO FOLDING FOOTREST
Innovative design that allows the footrest to fold at the same time as the wheelchair frame



7 FRONT BUMPER
Provides style and protection



8 BUBBLE LEVELS
Highly accurate and calibrated system for a quick and perfect adjustment

TECHNOLOGIES



MANTIS FRAME

Fuses a box frame in the back for enhanced cross brace rigidity with a cantilever frame in the front for a minimalist look.



T700 HIGH-TENSILE CARBON FIBER

One of the lightest and sturdiest material available, also renowned for its vibration damping properties.



RIGID UNIBODY FRAME

A unibody frame is much stronger and requires less maintenance than a standard two-part frame. It also reduces weight while maximizing propulsion efficiency.



SYMMETRICAL MOLDED CROSS BRACE 3D

Entirely symmetrical carbon fiber cross brace for reduced torsion and better energy distribution throughout the frame.



ULTRARIGID FOLDING SYSTEM

High-precision tolerances and oversized pivot axles for best-in-class propulsion efficiency.



FORGED VERTICAL AXLE PLATE

Offers the industry's most precise rear wheel adjustability. The vertical mounting maximizes stability and responsiveness.



BUBBLE LEVELS

Built-in highly accurate and calibrated gauges make caster adjustments quick and precise.



INTEGRATED IMPACT GUARD WITH TOP GRIP

Prevents daily use scratches to the front of the frame. Adds high friction grip for transfers. Protects vulnerable areas of lower extremities.



NEWTON ACCESSORIES

Parts and accessories designed to be lighter with improved functionality.

TECHNICAL SPECIFICATIONS

FRAME	Folding
MATERIAL	T700 High-tensile strength carbon fiber
TRANSPORT WEIGHT	11.9 lb. 5.4 kg (16 x 16 without rear wheels, wheel locks, armrests, cushion and anti-tippers)
LIGHTEST CONFIGURATION	19.4 lb. 8.8 kg, without wheel locks and wheels
WEIGHT LIMIT	265 lb. 120 kg 350 lb. 159 kg—HD Kit
WIDTH	14 in. to 17 in. 35.6 cm à 43.2 cm 18 in. to 20 in. 45.5 cm à 50.8 cm—HD Kit
DEPTH	14 in. to 20 in. 35.6 cm to 50.8 cm
FRONT SEAT-TO-FLOOR HEIGHT	14 in. to 21 in. 35.6 cm to 53.3 cm (with 4 in. to 6 in. caster)
REAR SEAT-TO-FLOOR HEIGHT	13 ½ in. to 20 ¼ in. 34.3 cm to 51.4 cm (with 22 in. to 26 in. wheel)

DIMENSIONS



SEAT WIDTH

14 in. to 20 in. | 35.6 cm to 50.8 cm



SEAT DEPTH

14 in. to 20 in. | 35.6 cm to 50.8 cm



FRONT SEAT-TO-FLOOR HEIGHT

14 in. to 21 in. | 35.6 cm to 53.3 cm



REAR SEAT-TO-FLOOR HEIGHT

13 ½ in. to 20 ¼ in. | 34.3 cm to 51.4 cm



BACK HEIGHT

9 in. to 21 in. | 22.9 cm to 53.3 cm



ARMREST WEIGHT

8 in. to 14 in. | 20.3 cm to 35.6 cm



FRONT FRAME ANGLE

70°, 75°, 80°, 85°, 90°



BACK ANGLE

85° to 110°



WHEEL CAMBER

0°, 3°, 6°



CENTER OF GRAVITY

1 in. to 4 in. | 2.5 cm to 10.2 cm



OVERALL WIDTH

20 ½ in. min. to 31 ½ in. max.
52.7 cm min. to 80 cm max.



WEIGHT LIMIT

265 lb. | 120 kg
350 lb. | 159 kg—HD Kit

COLOR CHART

COLORS ARE ON PROTECTORS. FRAME IS HIGH-GLOSS CARBON FIBER FINISH.



Black



White



Sky Blue



Acid Green



Ferrari Red



Fuschia



Sunkissed Orange

GO BEYOND!

Who we are: passionate innovators pushing the boundaries of what is possible. What we do: combine leading-edge engineering with innovative materials to create movement. What makes us proud: having our ultralight wheelchairs echo the love of life their users demonstrate each day. Through our unique approach and distinct attitude, our aim is to enhance lives, nourish a sense of freedom and revolutionize the way people see wheelchairs.

LEARN MORE To learn more about the VELOCE and find more information regarding our products, visit our website at motioncomposites.com



T 1 (866) 650-6555

F 1 (888) 966-6555

motioncomposites.com

0070275B-00-V2-BROCHURE VELOCE-EN

