



WOLTURNUS

# User's Manual

For Hawk



English



Wolturnus A/S recommends that you read this manual before using the wheelchair.

<b>1. Introduction</b>	<b>4</b>	<b>7. Accessories and Equipment</b>	<b>26</b>
1.1 Foreword	4	7.1 Height-adjustable push handles	26
1.2 Intended use	4	7.2 Wing back multi-adjustable back system	26
1.3 Usage	5	7.3 Wheel locks	27
1.4 Service	5	7.4 Upgrading rear wheels, pushrims and tyres	27
1.5 CE compliance	5	7.5 Upgrading casters	27
1.6 Liability	5	7.6 Quick-release axle with tetra grip	27
1.7 Returns	6	7.7 Sideguards	27
		7.8 Thermal bridge insulation for sideguards	27
<b>2. Safety</b>	<b>7</b>	7.9 Frame protectors	27
2.1 Symbols	7	7.10 Spoke protectors	28
2.2 Standards and directives	7	7.11 Calf-support straps for footrest	28
2.3 General safety instructions	7	7.12 Bags	28
2.4 Safety requirements for transport, assembly and storage	8	7.13 Seat Cushion	28
2.5 Safety requirements during use	8	7.14 Straps, belts and restraints	29
2.6 User requirements	8		
2.7 Type Labels	9	<b>8. Cleaning and Maintenance</b>	<b>30</b>
		8.1 Maintenance	30
<b>3. Product Description</b>	<b>10</b>	8.2 Cleaning and disinfection	31
		8.3 Changing tyre	31
<b>4. Delivery &amp; Preparation</b>	<b>12</b>	<b>9. Troubleshooting</b>	<b>33</b>
4.1 Delivery	12		
4.2 Preparation for use	12	<b>10. Technical Data</b>	<b>34</b>
<b>5. Transport and Storage</b>	<b>12</b>	<b>11. Instructions for Reuse</b>	<b>36</b>
5.1 Transport	13	11.1 Instructions for reuse	36
5.2 Transfer	13	11.2 Disposal	36
5.3 Slopes and overcoming obstacles	14		
		<b>12 Environment</b>	<b>37</b>
<b>6. Adjustment &amp; Set-up</b>	<b>15</b>	<b>13 Manufacturer and service.</b>	<b>38</b>
6.1 Adjustable features	15		
6.2 Tools	15		
6.3 Adjustment of the back angle	16		
6.4 Adjusting back depth and shape	16		
6.5 Adjusting back height	17		
6.6 Adjusting seat depth and shape	17		
6.7 Adjusting armrest height	18		
6.8 Adjusting balance point	18		
6.9 Adjusting footrest height	19		
6.10 Adjusting footrest angle and position	20		
6.11 Adjusting anti-tip device	20		
6.12 Adjusting wheel lock	21		
6.13 Adjusting seat height and angle	22		
6.14 Adjusting the caster angle	24		
6.15 Changing caster with front fork	25		

# 1 Introduction

## 1.1 Foreword

This user's manual provides users and helpers with essential information about the design, functions, use and maintenance of the Wolturnus Hawk wheelchair for children and adults. The manual contains the information necessary to ensure safe use of the wheelchair. It contains troubleshooting information with solutions (where/if applicable). The Hawk wheelchair is an easy-propulsion active wheelchair made by high-strength aluminum. The wheelchair's design makes it easy for the user to operate the chair independently. Because the back can be folded and both the rear wheel and side panels are removeable, the Hawk is easy to transport. The Hawk wheelchair is ideal for users who want to have an active daily life, indoors and outdoors.

The instructions in this manual are essential for safe and correct use of the wheelchair. Before starting to use it, it is important that both the user and helper read these instructions carefully - paying special attention to the safety instructions. The information provided ensures that the user gets the optimum advantage of the Hawk wheelchair's features and functions. Visually impaired users may obtain this information by having another person read for them. Furthermore, the manual is available on [www.wolturnus.dk/en/](http://www.wolturnus.dk/en/) where it is possible to enlarge the text or have the text read up by a suitable computer program. Keep this user's manual throughout the lifetime of the wheelchair: It contains information to future questions and it contains guidelines for adjusting and adapting the chair.

This user's manual has been produced in accordance with DS EN82079-1 'Preparation of instructions for use - Structuring, content and presentation'. It is divided into sections. The heading on each page contains the title of the overall section. The footer of each page displays the page number, year, and site of origin of the user's manual. It also includes the wheelchair's model.

## 1.2. Intended Use

The Hawk wheelchair is designed for individual mobility both indoors and outdoors. It is only suitable for persons who are unable to walk or have a mobility problem, but have unimpaired sight and cognition. Only equipment specified in this user's manual may be used with the Hawk wheelchair, and vice versa.

Wolturnus A/S does not guarantee this product if it is used with accessories or products from manufacturers other than those specified as part of the modular system.

Use of the Hawk wheelchair for any purpose other than the aforementioned will be considered incorrect. In the event of incorrect use, the user - i.e. not the manufacturer - is liable for resulting damage to persons or property.

The Hawk wheelchair may only be used by experienced users. For personal protection and in order to ensure that the Hawk wheelchair is used safely and correctly, it is a requirement that the user and helpers receive training and instructions prior to use of the Hawk wheelchair.

To ensure that the Hawk wheelchair is used correctly it has to be operated exclusively as described in this user's manual. The user bears final responsibility for accident-free use.

## 1.3 Usage

The Hawk wheelchair's modular design and versatility makes it suitable for users who have difficulties walking or who have a mobility handicap as a result of:

- Paralysis
- Loss of limbs (leg amputation)
- Limb defects or deformities
- Damaged or defective limbs
- Other illnesses

When adapting the wheelchair for the user, the following should be taken into account:

- Body, height and weight (max. load 120 kg.)
- Physical and mental constitution
- Age
- Residential circumstances
- Surroundings

### WARNING!

#### Risk of injury with incorrect use

To avoid the risk of getting fingers caught in the rear wheel spokes or wheel locks, and to avoid the risk of the chair tipping, children should not play with the wheelchair.

### INFORMATION

The wheelchair service and repairs may only be carried out by authorised personnel trained by Wolturnus A/S. In the event of problems, please contact Wolturnus A/S

## 1.4 Service

In the event of questions or problems that cannot be resolved using this user manual, please contact Wolturnus A/S customer service at (+45) 9671 7170.

Wolturnus A/S strives to provide full assistance to its customers in every respect and thus to ensure total satisfaction with the wheelchair. Wolturnus A/S contact information and a list of service locations can be found in section 13.

In the event that the wheelchair requires repairs at Wolturnus A/S for an extended period of time, a courtesy wheelchair can be borrowed for that period. Please contact Wolturnus A/S for further information.

## 1.5 CE Compliance

The Hawk wheelchair meets the requirements of the European Commission Directive 93/42/EEC for medical devices. The product is classified as a Class 1 on the basis of the classification criteria for medical devices in accordance with section IX of the directive. It follows that Wolturnus A/S has therefore, as manufacturer with sole liability, made a declaration of conformity in accordance with appendix VII of the directive.

## 1.6 Liability

Wolturnus A/S' warranty only applies if the product is used in accordance with the specified circumstances, purpose and instructions. The frame is covered by a 5-year warranty. Other parts manufactured by Wolturnus are covered by a 2-year warranty. Parts that are designed and manufactured by a third-party manufacturer and

mounted on a Wolturnus wheelchair are covered by a Wolturnus A/S warranty that is equal to the warranty provided to Wolturnus A/S by the third-party manufacturer.

Wolturnus A/S is not liable for injury or damage caused by:

- Components and parts that are not authorised by Wolturnus A/S.
- Alteration to the original surface treatment.
- Repairs or alterations to the wheelchair that are not carried out by Wolturnus A/S. All warranty repairs has to be carried out by Wolturnus A/S.
- Incorrect use of the wheelchair (e.g. playing basketball or rugby), or loads that exceed the construction or specified maximum for the wheelchair (in accordance with directive 93/42/EEC for medical devices).
- Circumstances in which the wheelchair is used by any party other than the original owner/user.
- Circumstances involving bad weather or dangerous situations, or in general all types of predictable negligence.
- Lack of maintenance.
- Cleaning with agents that contain acid or alkaline products, with high-pressure equipment or similar.

To keep updated about this product e.g. regarding new features, safety notice, product recalls check [www.wolturnus.dk](http://www.wolturnus.dk). Contact information and overview concerning all of Wolturnus's products are available at the website - or by contacting Wolturnus A/S customer service at (+45) 9671 7170.

### 1.7 Returns

In the event that the Hawk wheelchair has to be returned to the supplier or to Wolturnus A/S, e.g. for repairs, it must be transported in its original packaging for optimum protection. It follows that Wolturnus A/S recommends that the original packaging is retained throughout the lifetime of the wheelchair.

## 2 Safety

### 2.1 Symbols

#### **WARNING!**

Warning about risk of serious accident or injury

#### **CAUTION!**

Warning about risk of accident or injury

#### **NOTICE**

Warning about risk of technical damage

#### **INFORMATION**

Operational and service information

### 2.2 Standards and directives

All safety information in this user's manual is based on applicable national laws and regulations in the EU. For other countries, a declaration of conformity with applicable laws and national regulations is required.

In addition to the safety instructions contained in this user's manual, the user must be familiar with and must comply with applicable regulations from professional associations, concerning accident prevention and regarding environmental protection. All information contained in this user's manual must be complied at all times without limitations. The Hawk wheelchair is constructed in accordance with applicable regulations. The Hawk wheelchair safety level is approved by CE certification and a declaration of conformity.

### 2.3 General safety instructions

- The wheelchair may tip over.
- The Hawk Active wheelchair must only be used according to instruction in this manual.
- The Hawk Active wheelchair must only be used by trained users and must not be used by any other person than the user.
- The Hawk Active wheelchair must only be used to transport one person at a time.
- All safety instructions in this user's manual and all other relevant documentation must be kept and complied with throughout the lifetime of the chair. The user's manual must always be available to the user.
- The back and seat upholstery have passed the demanded tests for ignition, so they are fire-resistant. Nevertheless extreme care should be taken when in the vicinity of flammable items and fire, including, for example, lighted cigarettes.
- To avoid discomfort when using the chair, damaged back or seat upholstery should be replaced as soon as possible.
- Do not force the wheelchair over obstacles when using it on slopes.
- The Hawk wheelchair must not be used on stairs.
- Avoid getting in or out of the wheelchair while on slopes.
- The hip strap (accessory) provides the user with extra stability. It must never be used as a part of the strap attachment system when securing the chair for transport in a vehicle.
- Do not force the wheelchair forward on slopes exceeding 7°.
- Do not park on slopes that exceed 7°, even when the wheel locks are activated.

### 2.4 Safety requirements for transport, assembly and storage

- Only suitable lifting mechanisms must be used when transporting the wheelchair.
- The wheel locks must be activated when transporting the wheelchair using a lifting platform in situations in which the wheelchair has to be stationary, e.g. in lifts, buses, trains etc.
- The wheelchair must be placed in the middle of the platform and all components - e.g. the anti-tip device - and must be clear of any obstacles and their like if these are in risk of being tangled into the wheelchair during transport.
- When adjusting and adapting the chair, all attachment features - such as screws and nuts - must be fastened according to the instructions in this manual.
- For transport in vehicles we recommend that, whenever possible, the user is transferred to the vehicle's own seats and uses the vehicle's own safety belts. If this is not possible, it follows that the user must remain in his/her chair and an approved, mounted docking system in the vehicle must be utilized.

**2.5 Safety requirements in usage**

- The user and helpers must always ensure that the chair and its safety features are in a proper and safe condition before using the chair.
- The Hawk Active wheelchair must be inspected by a Wolturnus-authorized specialist at least once a year in order to ensure that the chair is in proper working order and safe to use.
- The chair must immediately cease to be used if any feature is defective or not operational or if any other circumstance arises which could lead to injury.
- Before starting to use the Hawk Active wheelchair, all mechanical adjustments (positioning the seat, accessories, etc.) must be carried out in accordance with the user's individual preferences, prerequisites and abilities. These adjustments may only be carried out by specialists authorized by Wolturnus.
- 120 kg is the maximum load for the Hawk active wheelchair. It must not be exceeded.
- The wheelchair's tyres must be inspected visually before use to ensure that there is sufficient tread depth and correct tyre pressure. The correct pressure is printed on the tyre.
- When used on public roads, the user must obey applicable traffic rules.
- The wheelchair should not be used on slippery surfaces (e.g. ice) or on very rough terrain (e.g. on gravel or small stones).
- When getting in and out of the wheelchair, the user's full weight should not be placed on the footrest or armrests. These cannot bear full body weight.
- Change direction at reduced speed only.
- The wheelchair must only be lifted by gripping the frame parts. Do not grip the footrest or armrests to lift the chair.
- The wheelchair must not be exposed to extreme temperatures, to high humidity or to environments with chlorine (e.g. in saunas or at swimming pools).
- The wheelchair's surface temperature can raise if it is exposed to extreme heat, e.g. in strong sunlight for an extended period of time. There is also a risk of very low surface temperature in the event of extremely cold weather.
- The anti-tip device should be used when travelling on uneven terrain or where hurdles are present. New users are advised to use the anti-tip device at all times.
- Never place fingers between the rear wheel spokes or between the rear wheel and the wheel locks. Caution is advised when travelling through narrow passages.

**2.6 User requirements**

- Before starting to use the wheelchair, the user and any helpers must read the user's manual thoroughly and be familiar with its contents.
- The Hawk Active wheelchair must only be used by trained users. To ensure this, the user and any helpers has to receive instruction in use of the chair from Wolturnus-authorized specialists.

**2.7 Type Labels**

A type label is attached to the wheelchair. The type label includes the following information:

	Caution
	The wheelchairs year of production
	Read the user's manual before using the wheelchair

The type label is placed on the cross tube under the seat facing forward as shown on image 1.

See the manual for fixation of wheelchair in motorvehicles for information about car fixation and safety. Label for car fixation is shown on image 1.



Image 1 Location of type labels, anti-tip warnings, and restraining points

### 3 Product description

The Hawk Active wheelchair is ideal for users who want to have an active daily life both indoors and outdoors. It can be adapted in various ways, which allows the user to adjust the wheelchair to meet individual preferences and requirements.

The Hawk wheelchair is designed for easy and quick adjustments. It is ideal for new users who need to make continual small adjustments. For example: A new user may find that maximum stability is achieved when the back axle and rear wheel are located relatively far back. A practised user may prefer to have the back axle and the rear wheel located closer to the front casters to reduce weight on the front. This makes the chair easier to manoeuvre because the primary weight is placed on the back axle and rear wheels. The Hawk wheelchair adjustment features are described in section 6 of this manual

The rear wheel and side panels can be removed and the folding back can be folded down in a locked position. This makes the Hawk wheelchair easy to transport and store. Due to this safety feature of the folding back the Hawk wheelchair can be lifted using the back column.

Because of the Hawk wheelchair's modular design: additional equipment and accessories can be purchased and retrofitted - e.g. the Wing Back ILSA system. A range of accessories are described in section 7 of this manual. The entire range of accessories, spare parts and additional equipment can be seen on [www.wolturnus.com](http://www.wolturnus.com).



Image 2 The Hawk wheelchair

## 4 Delivery and Preparations before Usage

### 4.1 Delivery

The delivery covers:

- The Hawk wheelchair with main components
- The user's manual
- Selected accessories (Accessories range. Go to section 7 in this manual)

#### INFORMATION

The range of accessories are determined by the product configuration that the user chooses when ordering the wheelchair.

#### CAUTION!

The wheelchair may tip over. Woltornus recommends to use the anti-tip device at all times.

Woltornus A/S delivers the Hawk wheelchair ready for use. All configurations that are part of the order have been made or will be set up upon delivery by the supplier or a consultant. The Hawk wheelchair is adapted to meet the user's personal preferences and requirements.

The wheelchair's functions can be tested by following the instructions in section 6 in this manual.

Troubleshooting: See section 9.

### 4.2 Preparation before usage

Before starting to use the Hawk wheelchair, it must be inspected to ensure that it is complete (checklist image 3, page 21) and that all functions are in proper working order. Woltornus A/S delivers the Hawk wheelchair ready for use.

#### Main components (Image 3):

1. Frame with back support and seat
2. Rear wheels
3. Casters
4. Side panels with/without armrest
5. Wheel locks
6. Footrest



Image 3. Main components

## 5 Transport and storage

### 5.1 Transport

For transport or storage, the rear wheels can be removed and the Hawk wheelchair folded. This makes it easy to handle and saves space:

- Fold sideguards down into the seat or remove them, depending on the mounting method.
- Unlock the backrest, fold it down and then tip the back into the locked position. Ensure that the back is correctly locked on both sides.
- Remove the rear wheels by pressing the Quick-release in the wheel hub. Pull off the wheel.

Because the Hawk wheelchair's back can be locked into a folded position, the chair can be lifted by the back rest tube while folded. Without the user, the wheelchair is suited for land and air transport. During storage, the Hawk wheelchair should be kept in a dry place and not exposed to humid conditions. For long-term storage, the wheelchair must be covered to protect it from dust. After transport or storage, mount the rear wheels, fold up the backrest, and mount the sideguards. Before use after long-term storage, complete the actions described in section 8.1 about maintenance.

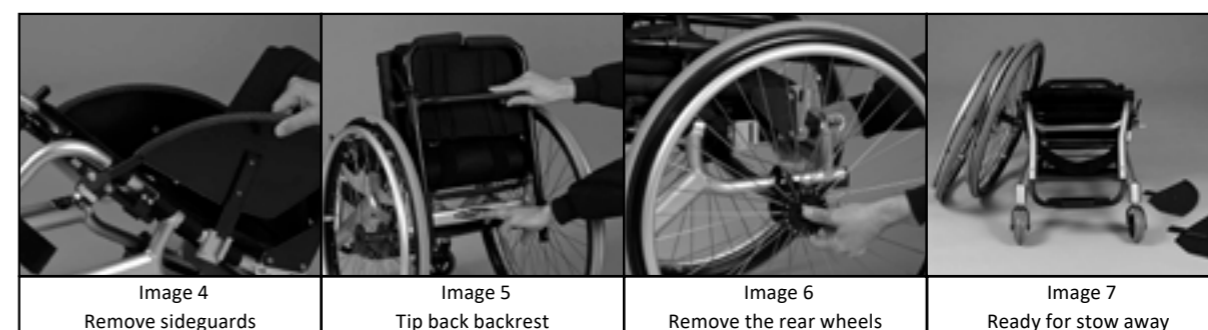

### 5.2 Transfer

The method of transfer to and from the chair is individually selected reflecting the preferences of the user. The most common method is transferring from the side or the front. When transferring for the first time and until the user gets used to transferring, it is recommended to have a helper present.

The following description is based on transfer without third-party help and from one wheelchair to another.

- Place the wheelchair beside and as close to the other seating surface as possible - preferably at a 90° angle.
- Apply the wheel locks on both chairs, when transferring from one wheelchair to the other wheelchair.
- Move the feet from the footrest and place them on the ground.
- Move from the chair close to the other seat. The method of actual transfer will vary from user to user. Use the method that works best.



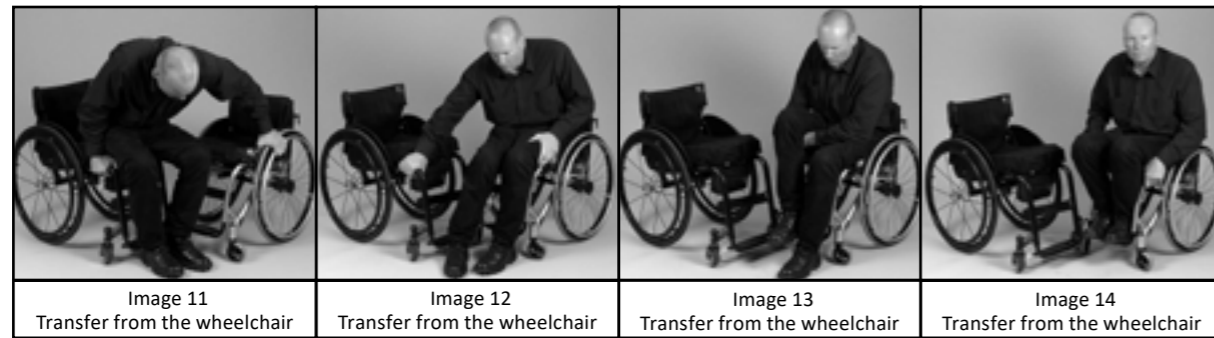

**CAUTION!**  
**Risk of damage due to overload.**  
 When getting in and out of the chair, the user must not place full body weight on the footrest or armrests.

**CAUTION!**  
 The wheel locks must be applied during transfer.

**5.3 Driving over slopes and obstacles**

When using the Active wheelchair, situations may occur where driving on slopes and crossing obstacles is necessary, such as:

- Driving up and downhill (image 15 og 16) .
- Driving over steps and curbs (image 17).
- Passage of obstacles greater than what the wheelchair user can climb on his own, use a ramp (image 18).

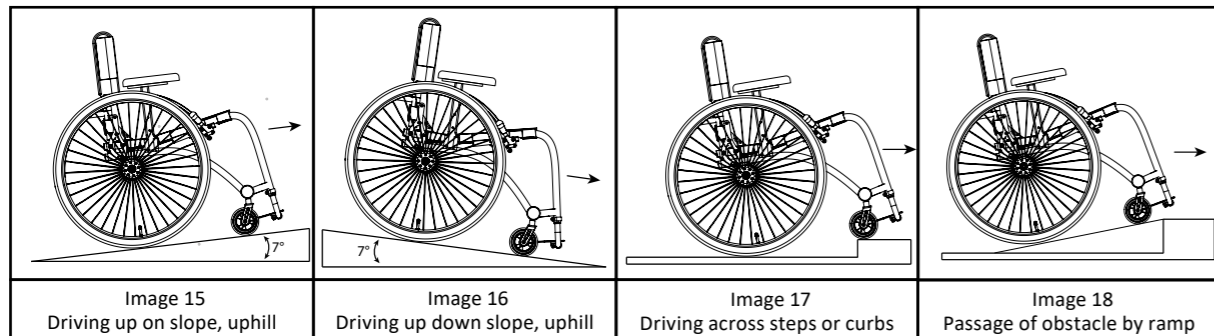

**CAUTION!**  
 Lean body forward when driving on slopes or passing obstacles, and get support from behind.

**WARNING!**  
**Danger when pushing wheelchair incorrectly**  
 Adjust push handles to fit obstacles.

**CAUTION!**  
 Always pass obstacles with a direct forward motion (at an angle of 90 degrees). Lift wheels over steps and curbs.

**WARNING!**  
**Danger when pushing passing obstacles without assistance.**  
 Always have assistants when passing obstacles.

**6 Adjustment and set-up**

**6.1 Adjustable features**

**CAUTION!**  
**Risk of accident due to loose screws**  
 After loosening threaded screws, they must be replaced with new screws or secured again with a medium-strength thread paste (e.g. EuroLock A24.20). After making adjustments to the wheelchair, screws and nuts must be tightened correctly.

The Hawk wheelchair can be adjusted in various ways.

When delivered, the height, width and angle of the seat and the back have been positioned in accordance with the customer's order as received by Woltornus A/S.

*The following can be adjusted by the user:*

- Back height, depth and angle
- Seat height, depth and angle
- Armrest and arm cushion
- Balance point position
- Footrest height and angle
- Anti-tip device height
- Wheel lock position
- Caster angle and change of caster and front fork

**6.2 Tools**

The following tools (image 19) are necessary for adjustments and settings described in this section:

- 5 mm Allen key (1)
- 6 mm Allen key (1)
- 8 mm single-head wrench (2)
- 10 mm single-head wrench (2)
- 13 mm single-head wrench (2)
- Torque wrench (3)
- Measuring tape (4)
- A bubble level (5)

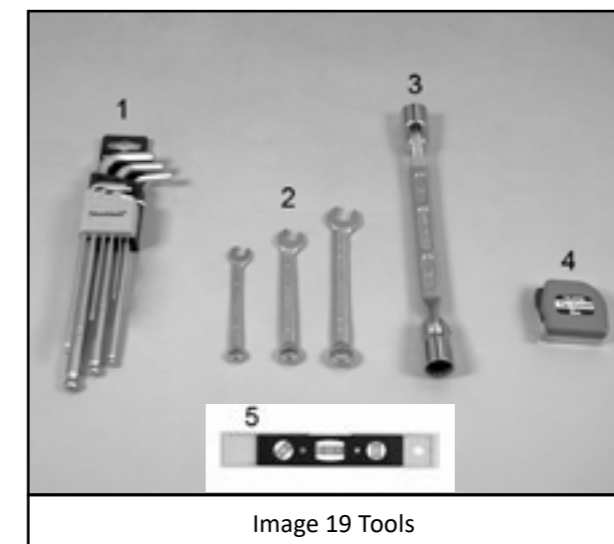

**NOTICE**  
 Damaged tools or incorrect use of tools can result in injury or in damage to the chair.



### 6.3 Adjustment of the back angle

The back angle can be adjusted 4° forward or 4° backwards. To adjust the back angle do the following:

- Extend the anti-tip device. This will ensure that the wheelchair does not tip over if the back is angled too far backwards.
- Loosen and remove the bottom bolt that secures the back and the locking bracket (Image 20).
- Move the bolt to one of the other notches in the plate. To pull the backrest further towards you, place the bolt further back. To lean the backrest further back, move the bolt forward.
- Adjust the bolt under the backrest post to the correct distance, when the backrest is in an upright position the bolt should rest on the seat tube (Image 21)
- Mount and tighten the bolts. Repeat the process on both sides.

When the back angle is folded it is adjustable. The back must be upright during the adjustment.

- Loosen and remove the bracket that locks the back into the folded position (Image 21).
- Turn the small plate which creates a cylindrical hole in the opposite end of the oval opening, and mount the bracket again.
- Repeat the process on both sides, and check that the back is properly locked after adjustment.

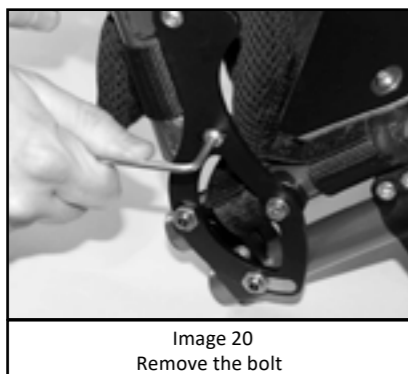

Image 20  
Remove the bolt



Image 21  
Loosen and remove the bracket

#### WARNING!

When the back has been adjusted, the wheelchair's point of gravity may have shifted, which may create a risk of backward tipping. Therefore, after adjusting the back, check the point of gravity and, if necessary, adjust it before using the chair (See section 6.9).

#### WARNING!

Ensure that the back angle has been adjusted equally on both sides and that, after adjustment, the back locks correctly into place both when upright and folded.

### 6.4 Adjusting the back depth and shape

The back's form can be adjusted to suit the individual user's requirements for support and balance. The Velcro straps under the back upholstery are used to adjust the back's shape.

- Fold up the back of the backrest upholstery to make the Velcro straps visible (Image 22).
- Loosen or tighten individual straps so that the back's form suits the user's requirements (Image 23).
- Fold down the back upholstery and secure it to the straps.

Adjustments to the back shape and depth affects the benefit the user gets from the chair substantially. Wolturnus A/S recommends that the form and the depth are initially adjusted with assistance from a Wolturnus A/S consultant or from the user's therapist.

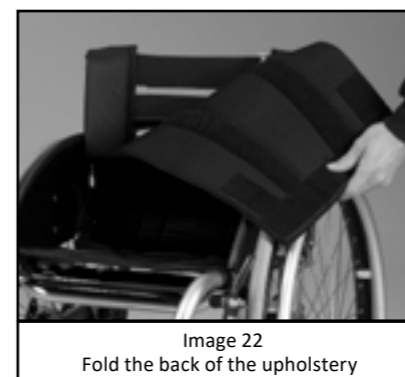

Image 22  
Fold the back of the upholstery

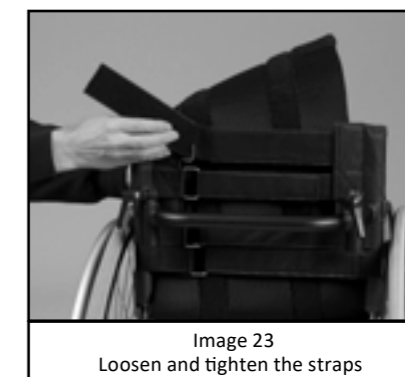

Image 23  
Loosen and tighten the straps

#### WARNING!

When the seat and/or back upholstery straps have been adjusted, the wheelchair's point of gravity may have shifted, which may create a risk of backward tipping. Therefore, after adjusting the seat and/or back upholstery, check the point of gravity and, if necessary, adjust it before using the chair. (See section 6.8).

### 6.5 Adjusting the back height

Back height is steplessly adjustable to meet the requirements and preferences of the user.

- Use a 5 mm Allen key to loosen the clamp on the base of the back (Image 24). Start with one side
- Adjust the back tube to the desired height.
- Tighten the clamp.
- Do the same on the other side. Ensure that both back tubes are set at the same height (Image 25).

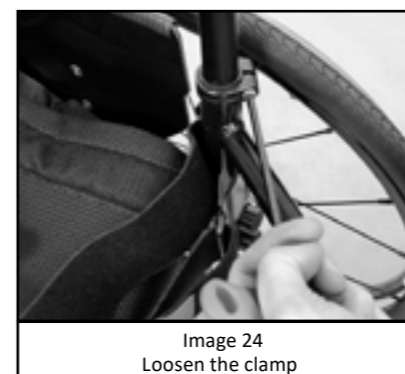

Image 24  
Loosen the clamp



Image 25  
Adjust the height of the back

### 6.6 Adjusting the seat depth and shape

When delivered, the seat length has been adjusted according to the measurement provided in the customer's order form, but it can be adjusted if required.

- Remove the seat cushion and release the seat cover from the straps. (Image 26).
- Push or pull the seat cover into the desired position (Image 27).
- Fasten the seat cover on the straps and mount the seat cushion.

The seat shape can also be altered, instructions are described below:

- Remove the seat cushion (Image 28).
- Release the Velcro straps and loosen/tighten them if required, then fasten them (Image 29).
- Mount the seat cushion.

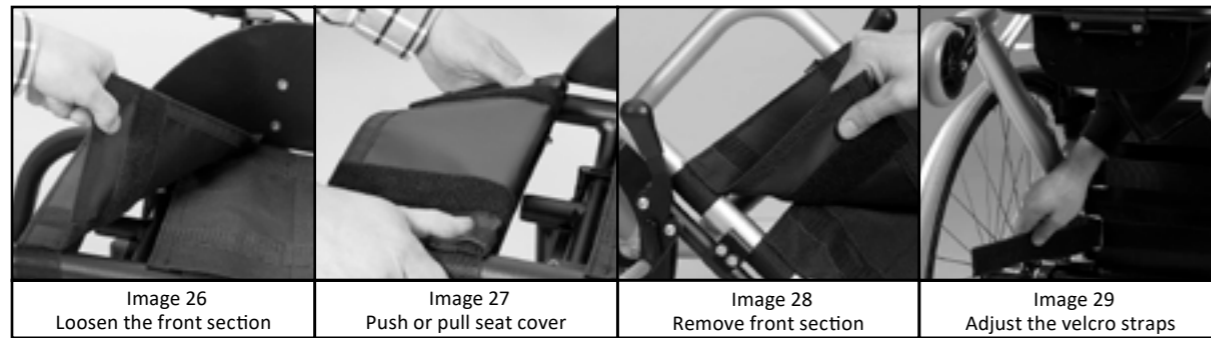
**WARNING!**

During strap adjustment of the seat and/or back upholstery, the wheelchair's point of gravity may have shifted, which may create a risk of backward tipping. Therefore, after adjusting the back, check the point of gravity and, if necessary, adjust it before using the chair. (See section 6.8).

**INFORMATION**

Notice; tightening the straps towards the front seat edge, not the back edge, will benefit some users. This creates a counterpoint for the back support's forward pressure on the lower body and a better hip position. Woltornus A/S recommends that this is done with assistance from a Woltornus A/S consultant or the user's therapist.

**6.7 Adjusting the armrest height**

- Lift of the armrest and use a 3 mm Allen Key to loosen the bolts that clamp in the baluster (Image 30 and 31).
- Mount the baluster to the desired height; then tighten the bolts.



Image 30  
Remove the armrest



Image 31  
Unscrew the baluster

**6.8 Adjusting balance point**

The wheelchair's point of gravity and stability can be changed by moving the rear axle forward or backward. By moving the rear axle and therefore the rear wheels forwards, the load on the casters is lightened. Hence it is easier to tilt the wheelchair up on the rear wheels. Practised users will find that this makes the wheelchair easier to manoeuvre. Moving the rear axle backwards makes it harder for the chair to tilt up on the rear wheels. The distance between the casters and the rear wheel is increased, which increases the stability during propulsion.

**Adjusting the rear axle:**

- Use the Quick-release mechanism to remove the rear wheels (Image 32).
- Move the wheel locks forward ensuring that they are not in the way as the rear wheels are remounted. Having adjusted the rear axle; the wheel locks must be adjusted again to ensure that the wheel locks are positioned correctly before usage (see section 6.12).
- Use a 5 mm Allen key to loosen the two bolts on the bracket that fastens the rear axle to the frame. Loosen them enough to allow the rear axle with console slide back and forward on the frame (Image 33).
- Find the desired position. Use a foot rule or ruler to check that the distance between the rear axle and the back edge is equal on both sides (Image 34).
- Use a 5 mm Allen key to tighten the bolt with a torque wrench. (Tension 10 Nm/7,4 ft.lbf/88 in.lbf.)
- Mount the rear wheels and adjust the wheel locks as described in section 6.12 (Image 35). Make sure the Quick-release mechanism is locked correctly; it audibly clicks when correctly in place.

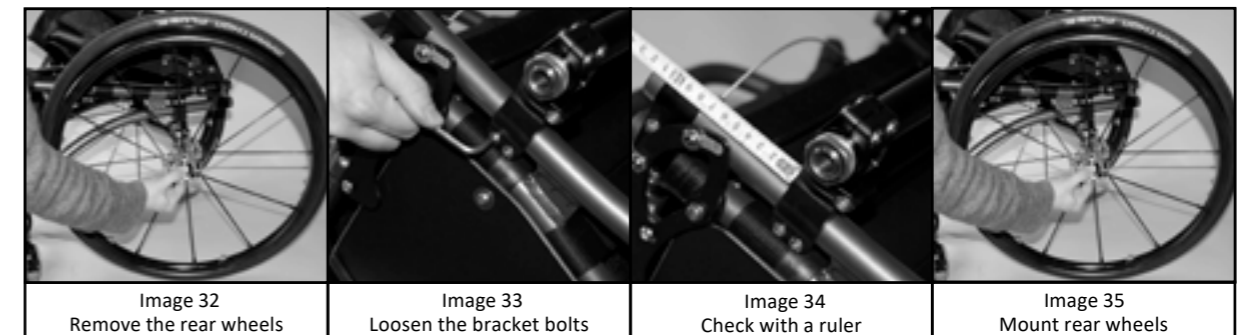
**CAUTION!**

To prevent the wheelchair unintentionally tipping backwards, it is recommended that the user always gets a helper to stand behind the wheelchair while trying out balance point adjustments.

**6.9 Adjusting the footrest height**

- Use a 5 mm Allen key to loosen the front frame clamp on both sides until the footrest is able to be freely slid up and down (Image 36).
- Raise or lower the footrest to the preferred height. Make sure that the footrest is even, e.g. not lop-sided (Image 37).
- Tighten the clamp. (Tension 4 Nm/3,0 ft.lbf/35 in.lbf.) If the clamp is too tight, it can bend the frame.

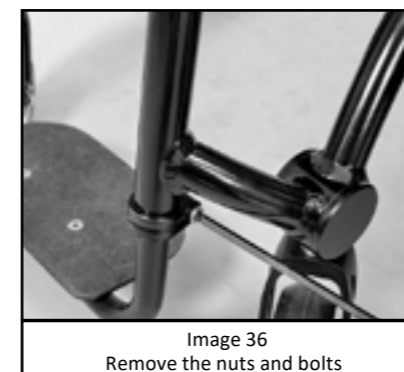

Image 36  
Remove the nuts and bolts



Image 37  
Adjust and remount bolts and nuts

### 6.10 Adjusting the footrest angle and position

- Use a 4 mm Allen key and 10 mm single-head wrench to loosen the nuts on the bracket underneath the foot plate (Image 38).
- Turn the foot plate until it is at the desired angle.
- Tighten the nuts.

The foot plate itself is adjustable can be moved further backward or forward.

- Use a 4 mm Allen key and 10 mm single-head wrench to loosen the bolts on the foot plate, then remove the foot plate (Image 39).
- Mount the foot plate in the second set of foot plate notches. It is also possible to turn the foot plate 180° so the front edge becomes the back edge (Image 40).
- Mount and tighten the bolts.

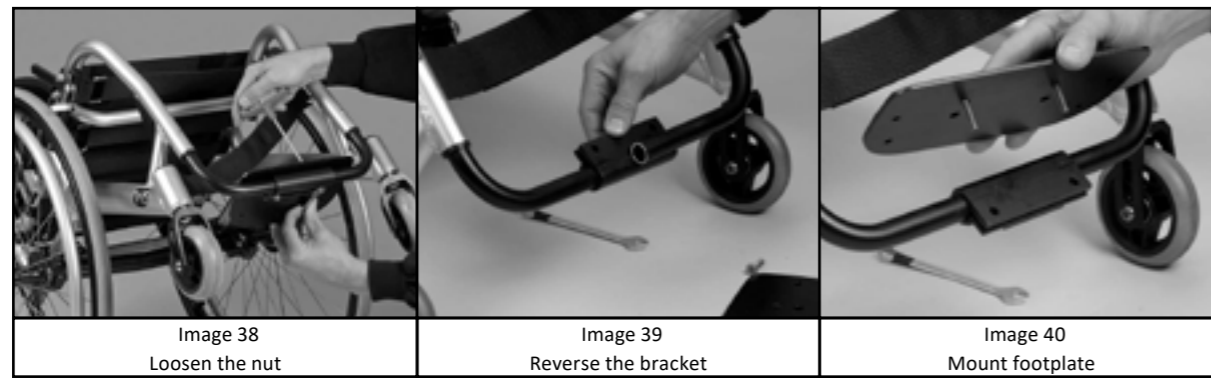

### CAUTION!

Never place full body weight on the footrest

### 6.11 Adjusting length of anti-tip

When extended, the anti-tip device prevents the wheelchair from tipping backwards. When making adjustments that can affect the balance point and distribution of weight, the anti-tip device should be extended.

- The height of the anti-tip device can be adjusted pressing in the button and pushing in or pulling out the lower part of the anti-tip (image 41).
- When it is at the correct height, tighten the bolt.

Standard height from floor to anti-tip device wheel: 60-70 mm (image 42).

### CAUTION!

Never use the anti-tip device as a tipping pedal. If used as a tipping pedal, the anti-tip device's spring function could be damaged. This would make the anti-tip device defective and put the user at risk.

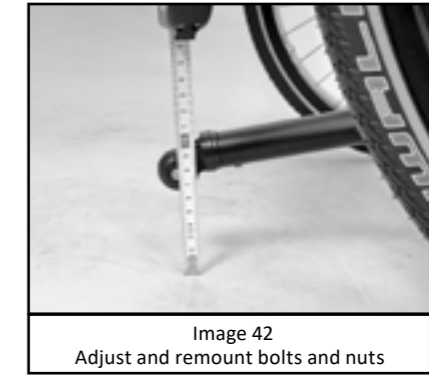
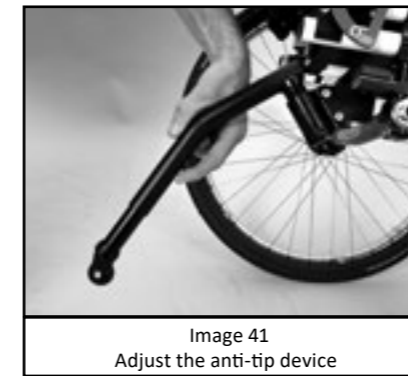

### 6.12 Adjusting wheel locks

The Hawk wheelchair is supplied with push wheel locks as standard. The push wheel locks are activated by pressing forwards and can be operated by the user. The push wheel locks are mounted on the wheelchair frame. Other types of wheel locks are mounted in the same way, so the following adjustment instructions can also be used for them.

If the balance point and therefore the position of the rear wheels is changed, or if the wheel size is changed, the wheel locks must be moved and adjusted at the same time.

The wheel locks must be moved forward before changing the balance point or rear wheels. After adjusting the balance point or changing the wheels, the wheel locks must be correctly adjusted.

#### Before adjusting the balance point or changing wheels:

- Use a 5 mm Allen key to loosen the two bolts in the console that fastens the wheel locks to the front-frame (Image 43).
- Move the wheel locks forward and tighten the console lightly so the wheel locks are not in the way.

#### After adjusting the balance point or changing wheels:

- Loosen the wheel locks.
- Move them backward so the brake pad, when activated, presses sufficiently on the tyre. This procedure ensures that the wheelchair is properly locked. As a rule, the brake pad should press the tyre at least 5 mm (Image 44).
- Tighten the bolt. Mount the axle and the bolts. (Tension 10 Nm/7,4 ft.lbf/88 in.lbf.)

It is vital that the left and right wheel locks have the same position. Use a foot rule, a measuring tape or a ruler to check that the wheel locks has the same degree of friction when activated.

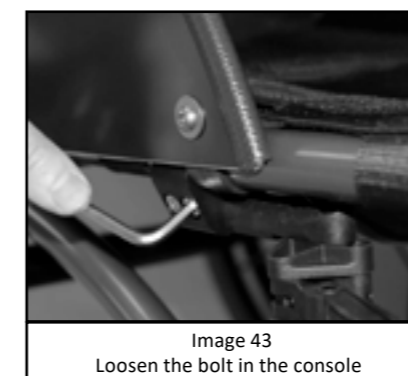

**CAUTION!**

**Ensure the correct tyre pressure.** Ensure the tyres have the correct pressure before using the chair again. The maximum air pressure limit is marked on the side of the tyre. It must always be minimum 3.5 bars (350 kPa) on rear wheels. Like push wheel locks, knee-lever wheel locks are only effective when air pressure is sufficiently high and when they are correctly positioned. (When locked, the brake pad should push the tyre in 5mm (allowing for technical alterations)).

**Using the push-action wheel locks**

1. Activate the wheel lock by pushing the handle forward (image 45). The wheel is now secured by the wheel lock.
2. Deactivate the wheel lock by pulling the handle backwards (image 46). The wheel is free of the wheel lock.

**Using the scissor wheel locks, small**

1. Activate the wheel lock by pushing the handle back towards the wheel (image 47). The wheel is now secured by the wheel lock.
2. Deactivate the wheel lock by pulling the handle away from the wheel (image 48). The wheel is free of the wheel lock.

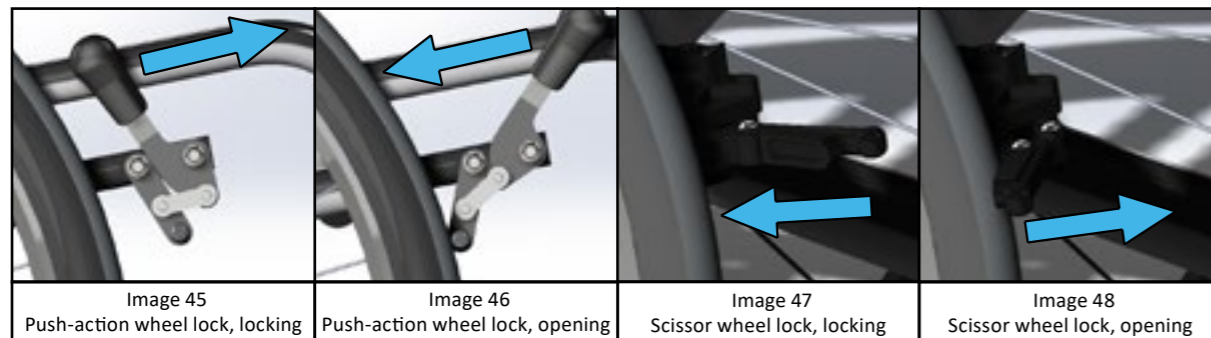

**WARNING!**

**Incorrect use of the wheel lock**

Never use the wheel locks as driving brakes. Always engage wheel locks in both sides. Check that the wheel locks are adjusted as advised.

**6.13 Adjusting the seat height and angle**

The seat height can be adjusted; e.g. if the user wants a different seat height than the one already setup or wants changes to a different wheel size but wants to retain the same seat height.

NOTE: Every time the front or rear height is changed or the wheel size is changed, please make sure that there is no too in or too out.

**Changing to a higher or lower seat height**

- Fold the back down, remove the rear wheels and turn the wheelchair over (Image 49).
- Loosen and remove the spacing axle between the rear axle console and the frame console. If there is no spacing axle, the rear axle will be directly joined to the frame console (Image 51).
- Mount the spacing axle correctly on the frame console. Make sure the axle is tightened sufficiently (see chart for correct relationship between seat height and rear wheel size.)
- Mount the rear axle console and tighten the clamp.
- Repeat on the opposite side of the wheelchair. Make sure that the spacing axles are mounted in the same

way so the seat height is even - i.e. not lop-sided.

- Adjust casters. See section 6.14

**Changing the wheel size and retain the seat height**

- Follow the aforementioned procedure.
- Use two 5 mm Allen keys to loosen and remove the bolt and the axle that mounts the caster in the front fork.
- Mount the axle and bolts. (Tension 10 Nm/7,4 ft.lbf/88 in.lbf.)

Rear wheels	Seat height rear with rear axle 1 degree camber				
	Spacing axle				
	0 mm	12,5 mm	25 mm	37,5 mm	50 mm
22" (radius 275 mm)	386,8 mm	399,3 mm	411,8 mm	424,3 mm	436,8 mm
24" (radius 300 mm)	411,8 mm	424,3 mm	436,8 mm	449,3 mm	461,8 mm
25" (radius 312 mm)	423,8 mm	436,3 mm	448,8 mm	461,3 mm	473,8 mm
26" (radius 325 mm)	436,8 mm	449,3 mm	461,8 mm	474,3 mm	486,8 mm

Table 1: Theoretical chart - correlation between the seat height, the rear wheel size and the connecting axle length.

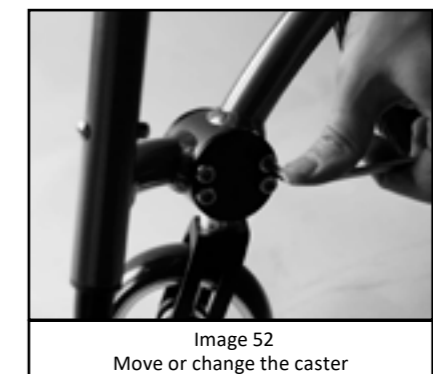
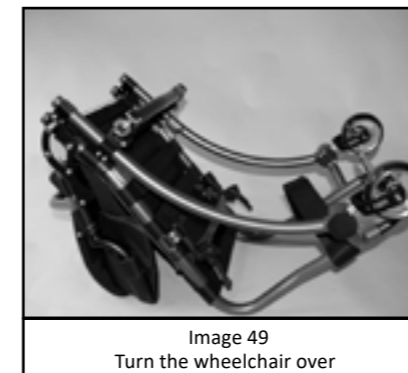

The seat angle can be adjusted in two ways. The caster can be adjusted, which changes the seat height to the front and thus the seat angle. The rear wheel can be adjusted, which changes the seat height to the rear and thus the seat angle.

**Adjusting seat height to the front**

To adjust the seat angle, the caster size can be changed. A larger caster raises the seat height to the front. A smaller caster lowers the seat height to the front.

Caster change: when only the caster is being changed, follow the previous instructions; when caster and front fork are being changed, follow the instructions in section 6.15.

**Adjusting seat height to the rear**

The seat angle can also be changed either by changing to larger or smaller rear wheels or by changing the spacing axle.

A larger spacing axle or rear wheel raises the seat height to the rear. A smaller spacing axle or rear wheel lowers the seat height to the rear.

**WARNING!**

During adjustment of the seat height and/ or angle, the wheelchair's point of gravity may have shifted, which may create a risk of backward tipping. Therefore, after adjusting the back, check the point of gravity and, if necessary, adjust it before using the chair. (See section 6.9).

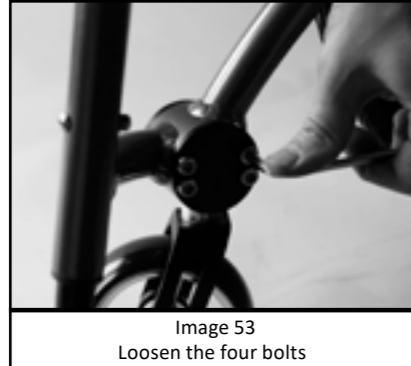

Image 53  
Loosen the four bolts

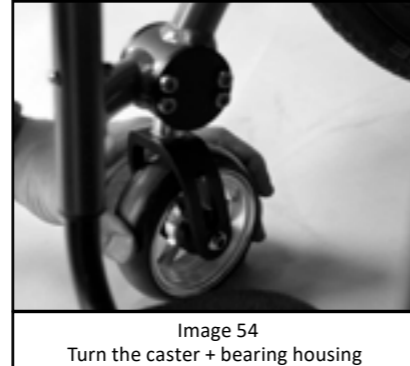

Image 54  
Turn the caster + bearing housing

**6.14 Adjusting the caster angle**

The caster angle may need adjustment if the caster size is changed or moved to another notch in the front fork.

- Use a 5 mm Allen key to loosen the four inner bolts on the caster casing (Image 53).
- Turn the caster and the bearing housing with cap. Use a bubble level to have the four inner bolts on the castor housing to be level (Image 54).
- Tighten the bolts. (Tension 10-14 Nm/7,4-10,3 ft.lbf/88-124 in.lbf.)

**NOTICE**

To avoid obstruction, ensure that the caster and front fork are vertical.

**6.15 Changing caster with front fork**

- Remove the four bolts in the caster casing and remove the bearing housing cap with a 5 mm Allen key (Image 55).
- Use a 19 mm wrench to remove the nut. Keep a grip on the caster so it does not swivel (Image 56). (Alternatively use a slotted screwdriver to keep the nut from turning and turn the caster.)
- Pull out the fork with caster and push the new one into place (Image 57).
- Tighten the nut. Do not tighten the nut too much; it must still be possible to rotate the front fork easily in the caster casing.
- Put the bearing housing cap loosely in place (Image 58).
- Before tightening the cap, use a bubble level to have the four inner bolts on the caster housing to be level. (Tension 10-14 Nm/7,4-10,3 ft.lbf/88-124 in.lbf.)



Image 55  
Remove the four bolts



Image 56  
Loosen the nuts



Image 57  
Change the caster with front fork

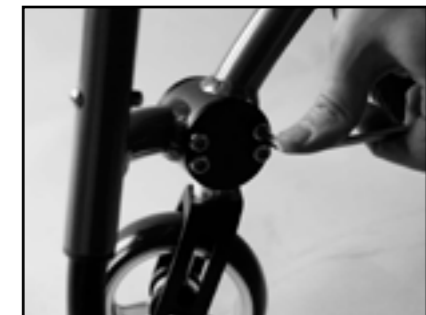

Image 58  
Adjust the angle

## 7 Accessories and equipment

A wide range of accessories and equipment are available for Wolturnus Active wheelchairs. The most popular accessories are described in this section. To see the full range of accessories and order information go to [www.wolturnus.com](http://www.wolturnus.com).

### 7.1 Height-adjustable push handles

Height-adjustable push handles can be chosen when ordering the wheelchair or purchased subsequently for retrofitting. If retrofitted, a bracket will be included as a replacement for the clamp on the back base.

#### Retrofitting height-adjustable push handles

- Loosen and remove the back upholstery.
- Remove the Velcro straps just above the back column and remove the clamp on the back base on both sides (image 59).
- Mount the bracket and triangle. The triangular plate with slots is used when mounting with Velcro straps. Use a 5 mm Allen key to tighten the bolts (Image 60).
- Mount the back tubes and the push handles in the bracket. Position them at the preferred height and then tighten the grip.
- Mount the Velcro straps in the triangular bracket and place the back upholstery over the straps.



### 7.2 Wing Back multi-adjustable ILSA system

The Wing Back ILSA system, developed by Wolturnus A/S, is a combined ergonomic support system for trunk and back that can be optimised. It can be used to meet a wide range of individual seating position requirements. The Wing Back ILSA system is exceptional because the upper part of the back can be adjusted for depth, width and height and also function as a side/body support. Independent of one another, the left and right sides are steplessly adjustable. Hence asymmetric adjustment is possible.

When installing a Wing Back ILSA on the backrest then make the following adjustments to make sure the backrest locks in folded position:

Loosen and remove the bracket that locks the back into the folded position (image 61).

Turn the small plate which creates a cylindrical hole in the opposite end of the oval opening, and mount the bracket again.

Repeat the process on both sides, and check that the back is properly locked after adjustment.



#### Adjusting the Wing Back ILSA system

- Use a 5 mm Allen key to loosen the clamp until the Wing Back is freely moveable (Image 62).
- Adjust the Wing Back ILSA System's height and angle to meet the user's preferences (Image 63).
- Tighten the clamp.
- Adjust the Velcro straps according to the procedure for a standard back (see section 6.4).

To adjust the depth of the Wing Back ILSA you should replace the horizontal plate (image 64)

### 7.3 Wheel locks

The Hawk wheelchair is supplied with push wheel locks as standard. A range of different wheel locks is available. These can be chosen when ordering the wheelchair or subsequently purchased for retrofitting.

### 7.4 Upgrading the rear wheels, the push rims and the tyres

The rear wheels and are upgradable to stronger, technically more advanced models; e.g. Spinergy rear wheels and titanium push rims or Schwalbe Marathon or MTB puncture-proof tyres.

The full range of rear wheels, push rims and tyres can be seen at [www.wolturnus.com](http://www.wolturnus.com)

### 7.5 Upgrading the casters

Different casters are available. Depending on the wheelchair's current wheel type, it may be necessary to replace both the caster and front fork. The full range of casters can be seen at [www.wolturnus.com](http://www.wolturnus.com).

### 7.6 Quick-release axle with tetra-grip for rear wheels

The Quick-Release mechanism with tetra-grip makes it easier for users with reduced handfunction to release the Quick-release and remove the rear wheels.

### 7.7 Sideguards

The Hawk active wheelchair is supplied with Dibond sideguards as standard. A range of other sideguards made of different materials, with and without mudguard, is available. The full range of sideguards can be seen on [www.wolturnus.com](http://www.wolturnus.com)

### 7.8 Thermal bridge insulation for sideguards

To insulate in order to prevent thermal bridges, the sideguards can be covered with neoprene. Aluminum sideguards are particularly well-suited for this treatment since aluminum conducts heat. Neoprene can either be glued on or secured with Velcro.

Templates for custom-made sideguards are retained at Wolturnus A/S ensuring that the right neoprene cover can be recreated in the future.

### 7.9 Frame protectors

Frame protectors are available to protect the front part of the frame from impact and scratches. Frame protectors are folded tightly on to the frame and secured with built-in Velcro straps.

### 7.10 Spoke protectors

Spoke protectors prevent fingers from getting caught in the spokes during propulsion.

A wide range of spoke protectors is available with a choice of neutral or patterned designs. The full range of spoke protectors can be seen on [www.wolturnus.com](http://www.wolturnus.com).

### 7.11 Calf-support straps for adjustable-by-angle footrests

Calf-support straps prevent the feet from sliding off the footrest. The straps are adjustable to ensure that the user's feet are correctly placed on the footrest. To adjust depth, loosen or tighten the Velcro on the calf-support strap.

### 7.12 Bags

Catheter bags are available in three leather models:

- Catheter bag for mounting on the back
- Small catheter bag for mounting under the seat
- Large catheter bag for mounting under the seat

### 7.13 Seat cushions

Seat cushions are available in various models and in the required size and thickness. The seat cushion range is available at the Wolturnus A/S web shop at [www.wshoppen.dk](http://www.wshoppen.dk).

### 7.14 Straps and belts

A range of straps and belts for different uses is available. The hip strap is one of the most used ones. It is recommended for usage when the wheelchair is in motion, ensuring that the user does not fall out. The full range of straps and belts can be seen on [www.wolturnus.com](http://www.wolturnus.com)

If the wheelchair is not delivered with a hip strap this can be mounted afterwards. The hip strap kit for retrofitting (image 65) consists of a hip strap, strap bracket (1), two clamps for mounting around the seat tube (2), plus bolts and the required number of nuts (3).

- Fit a clamp on the tube of the chair's frame against the wheelchair's back on each side (image 66)
- Thread the strap bracket as shown in the manual included in the strap package.
- Mount the hip strap bracket and tighten with the bolts included (image 67)



Image 66 Clamp on the frame

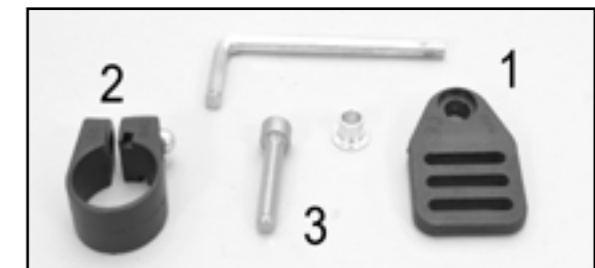

Image 65 Components and 5 mm Allen key



Image 67 Install strap bracket with the bolt

## WARNING!

A loose hip strap can cause the user to slide down and risk choking. The user must sit all the way back in the seat and the pelvis must be as straight as possible. The hip strap is tightened over the lower section of the pelvis. The hip strap should be tight enough to just allow a flat hand between the body and the hip strap.

## 8 Cleaning and Maintenance

### 8.1 Maintenance

Each time the wheelchair is used, operational parts, and particularly wheel locks, should be checked to ensure that they are in proper working order. After being loosened 2-3 times when making adjustments or changing parts, self-locking nuts should be replaced.

The following table gives an overview of how to maintain the wheelchair.

Component	Functions and inspection	Daily	Month	1/4 Year
Tyres	Tyres visibly pumped	X		
	Tyres undamaged	X		
	Test/adjust tyre pressure (see side of tyre)		X	
	Check thread depth (min. 1 mm)		X	
Rear wheel	Directional stability during use	X		
	Wheels rotate freely without misalignment		X	
	Nuts on rear wheel mounting bracket are tight		X	
Caster	No front fork obstruction		X	
	Wheels rotate freely without misalignment		X	
	Axle bolts correctly tightened		X	
	Cap bolts correctly tightened		X	
Folding back	Fasteners are not obstructed		X	
	Nuts and bolts are tightened		X	
	The pawl locks correctly in the bracket		X	
Footrest	All locking mechanisms are in working order		X	
	No obstructions or damage		X	
Upholstery	No damage or wear to upholstery		X	
	Securing straps function		X	
	Seat and back upholstery correctly positioned		X	
Wheel locks	Wheel locks in working order	X		
	Correct wheel lock pressure on tyre(s) (5 mm)		X	
Sideguards and armrests	Arm rest cushion is not loose	X		
	Sidguards and armrest mounting nuts and bolts are tightened.		X	
Screws	All nuts and screws are tightened			X

In the event of faults or missing parts, contact the supplier or Wolturnus A/S. Contact information: see section 13. Wolturnus A/S recommends that the wheelchair is serviced at least once a year by the supplier or Wolturnus A/S.

### INFORMATION

After storage of the wheelchair for a longer period of time, perform maintenance accordingly.

### 8.2 Cleaning and disinfection

The wheelchair should be cleaned regularly according to how often it is used and how dirty it is.

Clean the frame, plastic parts and wheels with a mild cleaning agent. After cleaning, dry all parts with a dry cloth.

Clean cushions and upholstery with warm water and washing-up liquid. Remove stains with a sponge or soft brush. Rinse afterwards with clean water and allow the parts to dry before mounting and using.

To disinfect, use water-based agents and follow the manufacturer's instructions.

#### NOTICE

The wheelchair must not be used in salt water. Avoid getting salt, sand and other dirt that can cause damage in the wheel bearings, caster mounting bracket or rear wheels. If this happens, the bearings should be replaced.

#### NOTICE

Do not wet-wash. Do not use high-pressure equipment or a water jet. The wheelchair components must not be put in a washing machine.

#### NOTICE

Do not use corrosive cleaning agents, solvents or hard brushes.

#### NOTICE

Clean the seat and back upholstery, cushions, handles and armrest before disinfecting.

### 8.3 Changing a tyre

If a tyre is punctured, the user or a helper may be able to change it themselves. It requires some hand strength, practical ability and suitable tools. It is advisable to always have a puncture repair kit and an air pump for emergencies (excluding situations with puncture-proof tyres). Suitable air pumps, puncture repair kits or puncture sprays that fill the tyre with expanding foam can be purchased at bicycle shops.

#### Removing tyres and tubes

- Gently pull the tyre edge over the rim edge with a lever (or two, if it is sitting very tightly). Take care not to damage the rim or tube (image 68).
- Screw off the valve nut and pull the valve out from the rim and rim strap.
- Pull the tube out from between the tyre and rim (image 69).

#### Repair and check-ups

- Repair the tube according to the instructions on the repair kit or replace it with a new tube.
- Before remounting the tyre and tube, make sure no foreign objects that may have caused the puncture are caught in the rim or tyre.
- Ensure that the tyre band is intact. It protects the tube from spoke damage.
- Push the tube into place between the tyre and rim.

#### Mounting tyres

- Gently pull the clear tyre edge over the edge of the rim. Start with the valve.
- Check that there are no twists at all in the tube, otherwise air can get out.



- Work the whole way around until the last section of the tyre edge is taut and can be edged into place with one or two levers.

**Pumping**

- Check on both sides that the tube is not caught between the tyre edge and rim.
- Push the valve lightly in and pull out again to make sure that it is not caught on the tyre edge.
- Fill the tyre with air to the point that it can still be pressed in with a thumb. If the control line on both sides of the tyre indicates the same distance to the rim edge, the tyre is centred. If the tyre is not centred, let some air out and adjust the tyre until it is centred. Now pump the tyre up to the maximum working pressure (see side of tyre) or at least 3.5 bars (350 kPa) and screw the dust cap on tightly.



Image 68  
Pull the tyre edge over the rim



Image 69  
Pull out the tube

**CAUTION!**

Ensure the tyres have the correct pressure before using the chair again. The maximum air pressure limit is marked on the side of the tyre. It must always be minimum 3.5 bars (350 kPa) on rear wheels. Like push wheel locks, knee-lever wheel locks are only effective when air pressure is sufficiently high and when they are correctly positioned. (When locked, the brake pad should push the tyre in 5mm (allowing for technical alterations)).

**INFORMATION**

NB: Pneumatic tyres are good for handling and manoeuvring. Solid tyres are good for work situations in which there might be a risk of debris or other items that could puncture a pneumatic tyre.

## 9 Troubleshooting

During routine maintenance, it may be necessary to make adjustments or repair faults. In most cases, the solution to the problem can be found on the following list:

Problem	Solution	Reference
The caster makes noise or is resistant	Check if there is dirt between the fork and caster or dirt in the fork ball-bearings.	Section 6.17
	Clean off the dirt and tighten the screws. If they do not roll freely, change the ball-bearings.	Section 6.18
The front fork shakes	Loosen and remove the bearing housing cap. Then tighten the nut to a degree where the front fork with wheel can still rotate easily.	Section 6.18
	Make sure that the caster is vertical.	
The rear wheel makes a loud clicking noise	Check and tighten the spokes and the push rim mounting screws. Only to be done by professionals!	
	Check that nothing is pushing against the rear wheel or the rear wheel's spokes.	
Rear wheel resistance	Check if the rear wheel is misaligned.	
	Check tyre pressure	
	Check if, for example, the side panel or another part is pushing against the rear wheel.	
Loud clicking noise	Check if the rear wheel bearings are worn down and need replacement.	Section 6.17 Section 6.18
	Check and tighten the screws in the rear wheel and caster mounting brackets	
The footrest is lopsided	Check that the foot plate is horizontal and adjust the footrest height.	Section 6.10-12
The wheel locks do not work properly	Check that both wheel locks are correctly positioned.	Section 6.14
	Inspect the rear wheel tyres for wear and tear, and for faulty tyre pressure.	Section 8.3

If the problem cannot be solved with the aid of the troubleshooting section, contact the supplier or Wolturnus A/S. Contact information, go to section 13.

### 10 Technical data

Weights and Measures	SW 350	SW 375	SW 400	SW 425	SW 450	SW 475	SW 500
Seat Width (SW) (mm)	350	375	400	425	450	475	500
Total Width (TW) (mm)	537	562	587	612	637	662	687
Seat Width - adjustability	No	No	No	No	No	No	No
Seat Depth (SD) (mm)	350-500	350-500	350-500	350-500	350-500	350-500	350-500
Seat Depth - adjustability	Yes	Yes	Yes	Yes	Yes	Yes	Yes
Total Length (TL) (mm)	730-940	730-940	730-940	730-940	730-940	730-940	730-940
Total Length Folded (mm)	670-840	670-840	670-840	670-840	670-840	670-840	670-840
Total Height	690-977	690-977	690-977	690-977	690-977	690-977	690-977
Folded Height (mm)	540-600	540-600	540-600	540-600	540-600	540-600	540-600
Seat Height Front (SH-f) (mm)	450-545	450-545	450-545	450-545	450-545	450-545	450-545
Seat Height rear (SH-r)(mm)	390-477	390-477	390-477	390-477	390-477	390-477	390-477
Seat Height - adjustability	Yes	Yes	Yes	Yes	Yes	Yes	Yes
Footrest to Seat (VSL)	350-480	350-480	350-480	350-480	350-480	350-480	350-480
Leg to Seat surface angle	75°-100°	75°-100°	75°-100°	75°-100°	75°-100°	75°-100°	75°-100°
Back Height (BH) (mm)	300-400	300-400	300-400	300-400	300-400	300-400	300-400
Back Height - adjustability	Yes	Yes	Yes	Yes	Yes	Yes	Yes
Backrest Angle - adjustability	+/- 4°	+/- 4°	+/- 4°	+/- 4°	+/- 4°	+/- 4°	+/- 4°
Locking of Back when Folded	Yes	Yes	Yes	Yes	Yes	Yes	Yes
Front Frame Model	UV	UV	UV	UV	UV	UV	UV
Turning Radius (mm)	510-640	510-640	510-640	510-640	510-640	510-640	510-640
Max. Tare-weight with Rear Wheels* (kg)	14	14	14	14	14	14	14
Max. Tare-weight without Rear Wheels* (kg)	11	11	11	11	11	11	11
User Weight	Max. 120 kg	Max. 120 kg	Max. 120 kg	Max. 120 kg	Max. 120 kg	Max. 120 kg	Max. 120 kg
Rear Wheel Camber	1° - 3°	1° - 3°	1° - 3°	1° - 3°	1° - 3°	1° - 3°	1° - 3°
Adjustable Rear Axel (RA) (mm)	20-90	20-90	20-90	20-90	20-90	20-90	20-90

\*Dependent on configuration.  
 NB: Max. user weight 120 kg will not usually be relevant when choosing a narrow seat width.  
 NB: Weight of individual parts will vary based on configuration. Contact Wolturnus A/S for information about these.

Weights and Measures	SW 350	SW 375	SW 400	SW 425	SW 450	SW 475	SW 500
(Optional) Securing in Vehicles	Yes	Yes	Yes	Yes	Yes	Yes	Yes
(Optional) Arm Rest	Yes	Yes	Yes	Yes	Yes	Yes	Yes
Height Seat tube to Armrest (AS) (mm)	200-300	200-300	200-300	200-300	200-300	200-300	200-300
Backrest to front armrest	280-290	280-290	280-290	280-290	280-290	280-290	280-290
(Optional) Pushrim Ø	490-560	490-560	490-560	490-560	490-560	490-560	490-560
(Optional) Anti-tip Device	Yes	Yes	Yes	Yes	Yes	Yes	Yes

Stability Direction	Scenario	Tipping Angle
Downhill	Front Wheels Unlocked	15°
	Driving Wheels Locked	7°
Uphill	Driving Wheels Unlocked	11°
	With Anti-tip Devices Engaged	15°
Sideways	Left	15°
	Right	15°

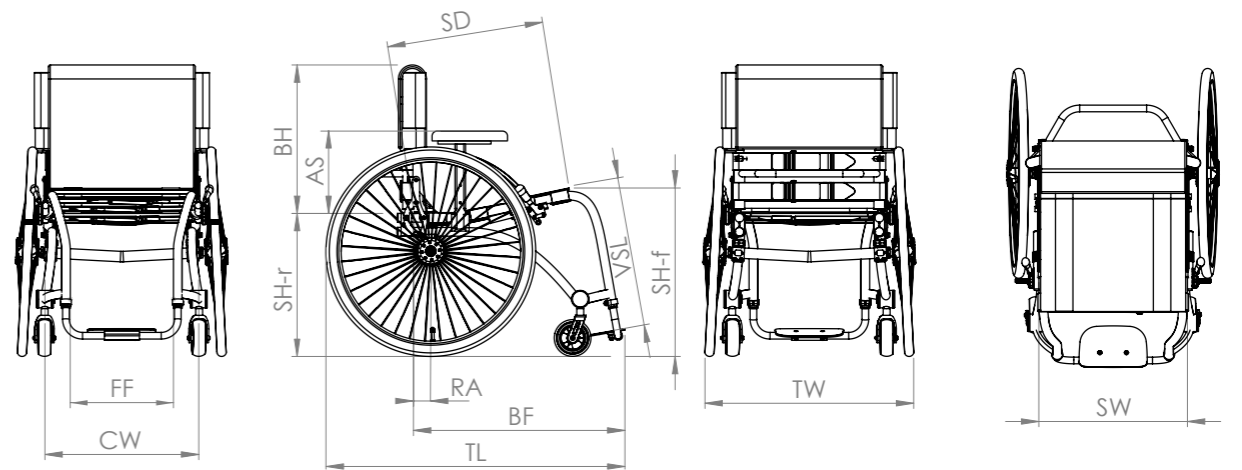

SW	Seat Width	RA	Front of Back to Center Rear Axel
SD	Seat Depth	BF	Front of Back to front Footrest
SH-r	Seat Height rear	FF	Inner Front Frame
SH-f	Seat Height front	CW	Center Caster bearings
BH	Back Height	TW	Total Width
AS	Height Armrest to Seat Tube	TL	Total Length
VSL	Seat Surface to Rear Footrest		

## 11 Instructions for reuse

### 11.1 Instructions for Reuse

The Hawk Active wheelchair is suitable for reuse by a subsequent new owner. It is essential that the wheelchair's measurements and equipment are tailored to suit the new user. It follows that it is important to ensure that the chair's functions and features have not been altered to a degree that could create a safety risk for the new user or any third parties during the lifetime of the chair.

Based on market studies and on its knowledge of contemporary technology, Wolturnus A/S has calculated that the Hawk Active wheelchair, when used, serviced and maintained in accordance with the original instructions, has a lifetime of 5 years (excluding time kept in storage by an authorised dealership or the user). Note that with careful care and proper use, the Hawk active wheelchair can be used for a longer period than the defined lifetime.

Prior to reuse, the wheelchair must be carefully cleaned and disinfected. Then the product must be inspected by an authorised specialist to assess its condition, wear and tear, and damage. All worn or damaged parts and components that do not suit or are not designed for the new user must be replaced. This user's manual includes a service plan (see maintenance chart section 8) and detailed information about the Hawk wheelchair.

### 11.2 Disposal

The Hawk wheelchair is delivered in a brown cardboard box that can be handed into to recycling centres or cardboard collection points. The protective bubble wrap on the frame must be disposed of as combustible waste. The aluminum frame must be disposed of as metal. The upholstery and side panels must be disposed of as combustible waste.

## 12 Environment

Wolturnus A/S strives to respect the environment as far as possible. An assessment has been done to determine the Hawk wheelchair's effect on the environment during its life cycle. During development, materials and forms are chosen that minimise waste of energy and material during production.

Wolturnus A/S has a unique approach to individual user's measurement and to the subsequent special design of the chair to meet the user's needs, preferences and requirements. Combined with the wheelchair's mechanical quality, this ensures that the user can use the wheelchair for many years. The Hawk wheelchair lifetime is calculated to be approximately 5 years if maintained according to the instructions in this user's manual. The long lifetime limits the wheelchair's effect on the environment.

Furthermore, meticulous quality control throughout the production process ensures that faults are rare, which limits the need to use superfluous resources on repairs or replacement products.

Generally, all functions, working processes and labor at Wolturnus A/S are carried out with respect for the environment. Aluminum residue after the production process is collected in containers and delivered for recycling. During the mounting process, the usage of hazardous agents is kept to a minimum. Furthermore all work processes meet occupational safety requirements (APV). The usage of all materials is continually optimized to ensure minimum waste.

## 13 Manufacturer and service locations

### Service locations

Visit the following pages to find authorised distributors representing Wolturnus A/S in other countries: <http://wolturnus.dk/en/partners/> & <http://wolturnus.dk/de/berater/>

After-sales spare parts are available for all Wolturnus handbikes.

In Denmark, authorised sales consultants throughout the country are in direct contact with Wolturnus A/S about spare parts, service and repairs.

### Manufacturer

Wolturnus A/S

Halkærvej 24B

Bislev

DK-9240 Nibe

Danmark

Tel: +45 9671 7170

Fax: +45 9671 7180

Email: [info@wolturnus.dk](mailto:info@wolturnus.dk)

Webide: <http://www.wolturnus.dk>

Webshop for purchasing equipment and spare parts: <http://www.wolturnus.dk/en/products/>

Wolturnus A/S active wheelchairs are CE approved in accordance with the requirements of Directive 93/42/EEC for medical devices (Class 1) and DS/EN 12183. Furthermore, the wheelchairs conforms to the standards 'requirements and test methods for static, impact and fatigue strengths' (ISO 7176-8) and requirements for resistance to ignition in accordance with ISO 7176-16.

**Kundeservice/Customer Service**

Wolturnus A/S  
Skalhuse 31  
9240 Nibe

Telefon: +45 96 71 71 70  
[www.wolturnus.dk](http://www.wolturnus.dk)  
Mail: [info@wolturnus.dk](mailto:info@wolturnus.dk)

**Produktion/Production**

Wolturnus A/S  
Halkjærvej 24B  
9240 Nibe



**WOLTURNUS**